



OWNERS MANUAL

ABI CLASSIC SPREADERS

25/50/65 CUBIC FOOT GROUND DRIVEN MODELS

MANUFACTURED AFTER APRIL 24, 2016



[**VIEW ABI SUPPORT WEB PAGE**](#)



FOR YOUR RECORDS:

Record your machine's information and serial number in the space provided below. ABI will use this information to give you prompt service when you order parts or need support.

This document covers several models. Features may vary by model. Not all features in this document are applicable to all models. The model depicted may differ from yours.

MODEL AND SERIAL NUMBER:

Model Number:	_____
Serial Number:	_____
Invoice Number:	_____
Purchaser's Name:	_____

CONTACT INFORMATION:

ABI Attachments, Inc
520 S. Byrkit Ave.
Mishawaka, IN 46544

CUSTOMER SUPPORT:

Email: support@abiattachments.com
Phone: (877)788-7253
Website: abisupport.com

WARRANTY INFORMATION:

Please see separate enclosure for warranty details.

TABLE OF CONTENTS:

For Your Records.....	2
Warning Labels.....	3
Safety.....	3
Uncrating & Initial Setup.....	7
Operations Guide.....	9
Troubleshooting & FAQs.....	10
Maintenance: Grease Bearings.....	11
Adjustment Due To Wear Over Time.....	12
Specifications.....	16
Slow Moving Vehicle Sign.....	17
Replacement Parts.....	17
Parts Description.....	18
Options.....	44
End Gate.....	44
Litter Pan.....	46
Ball Hitch.....	50
Notes.....	51

WARNING LABELS:

	<p style="text-align: right;">10-10976</p> <h2 style="text-align: center;">⚠ WARNING</h2> <p style="text-align: center;">CRUSHING AND PINCHING HAZARD</p> <ul style="list-style-type: none">● Be extremely careful handling various parts of the machine. They are extremely heavy and hands, fingers, feet and other body parts could be crushed or pinched between tow vehicle and implement.● Adjust controls from tow vehicle seat only.● Do not stand between tow vehicle and implement when tow vehicle is in gear.● Make sure parking brake is engaged before going between tow vehicle and implement.● Stand clear of machine when in operation or being raised or lowered.
---	---

	<p style="text-align: right;">10-10978</p> <h2 style="text-align: center;">⚠ WARNING</h2> <p style="text-align: center;">TO PREVENT SERIOUS INJURY OR DEATH:</p> <ul style="list-style-type: none">● Avoid unsafe operation and maintenance. Do not operate or work on this machine without reading and understanding the operator's manual.● If manual is lost, call 877-788-7253● Do not allow riders and keep others away during operation.● Lower implement, stop tow vehicle engine, set park brake and remove ignition key before servicing, adjusting, repairing or unplugging.● Safely support and secure implement before adjustments or repairs are made.● Park or block implement so it will not roll when disconnecting from tow vehicle.● Never place any part of the body underneath implement or between movable parts even when the engine has been turned off.● DO NOT operate or transport at high speeds.● DO NOT operate or transport on steep slopes.
---	--

SAFETY:

CAUTION: Our machines are designed considering safety as the most important aspect and are the safest available in today's market. Unfortunately, human carelessness can override the safety features built into our machines. Injury prevention and work safety, aside from the features on our tools, are very much due to the responsible use of the equipment. It must always be operated prudently following with great care, the safety instructions laid out in this manual.

- Before operating equipment, read and understand the operator's manual.
- Thoroughly inspect the implement before initial operation to assure that all packaging materials, i.e., wires, bands, and tape have been removed.
- Personal protection equipment including safety glasses, safety shoes, and gloves are recommended during assembly, installation, operation, adjustment, maintaining and/or repairing the implement.
- Operate the implement only with a tractor equipped with an approved Roll-Over-Protective-System (ROPS). Always wear your seat belt. Serious injury or even death could result from falling off the tractor.
- Operate the implement in the daylight or under good artificial light. Operator should always be able to clearly see where they are going.
- Ensure the implement is properly mounted, adjusted and in good operating condition.

STARTING AND STOPPING

- Be sure that no one is near the machine prior to engaging or while machine is working.
- Be sure the tractor is in neutral before starting the engine.
- After striking an obstacle, shut the tractor off, remove key and thoroughly inspect for damage before restarting.



WARNING! The SAFETY ALERT SYMBOL indicates there is a potential hazard to personal safety involved and extra safety precaution must be taken. When you see this symbol, be alert and carefully read the message that follows it. In addition to design and configuration of equipment, hazard control, and accident prevention are dependent upon the awareness, concern, prudence, and proper training of personnel involved in the operation, transport, maintenance, and storage of equipment.



CALIFORNIA PROPOSITION 65

WARNING! Cancer and reproductive harm - www.P65Warnings.ca.gov

SAFETY AT ALL TIMES

Careful operation is your best assurance against an accident. All operators, no matter how much experience they may have, should carefully read this manual and other related manuals, or have the manuals read to them, before operating the tow vehicle and this implement.

- Thoroughly read and understand the "Safety Label" section. Read all instructions noted on them.
- Do not operate the equipment while under the influence of drugs or alcohol as they impair the ability to safely and properly operate the equipment.
- The operator should be familiar with all functions of the tow vehicle and attached implement and be able to handle emergencies quickly.
- Make sure all guards and shields appropriate for the operation are in place and secured before operating implement.
- Keep all bystanders away from equipment and work area.
- Start tow vehicle from the driver's seat with hydraulic controls in neutral.
- Operate tow vehicle and controls from the driver's seat only.
- Never dismount from a moving tow vehicle or leave tow vehicle unattended with engine running.
- Do not allow anyone to stand between tow vehicle and implement while backing up to implement.
- Keep hands, feet, and clothing away from power-driven parts.
- While transporting and operating equipment, watch out for objects overhead and along side such as fences, trees, buildings, wires, etc.
- Do not turn tow vehicle so tight as to cause hitched implement to ride up on the tow vehicle's rear wheel.
- Store implement in an area where children normally do not play. When needed, secure attachment against falling with support blocks.

SAFETY PRECAUTIONS FOR CHILDREN

Tragedy can occur if the operator is not alert to the presence of children. Children generally are attracted to implements and their work.

- Never assume children will remain where you last saw them.
- Keep children out of the work area and under the watchful eye of a responsible adult.
- Be alert and shut the implement and tractor down if children enter the work area.
- Never carry children on the tractor or implement. There is not a safe place for them to ride. They may fall off and be run over or interfere with the control of the tow vehicle.
- Never allow children to operate the tow vehicle, even under adult supervision.
- Never allow children to play on the tow vehicle or implement.
- Use extra caution when backing up. Before the tractor starts to move, look down and behind to make sure the area is clear.

SHUTDOWN & STORAGE

- If engaged, disengage power take-off.
- Park on solid, level ground and lower implement to ground or onto support blocks.
- Put tractor in park or set park brake, turn off engine, and remove switch key to prevent unauthorized starting.
- Relieve all hydraulic pressure to auxiliary hydraulic lines.
- Wait for all components to stop before leaving operator's seat.
- Use steps, grab-handles and anti-slip surfaces when stepping on and off the tractor.
- Detach and store implement in an area where children normally do not play. Secure implement using blocks and supports.

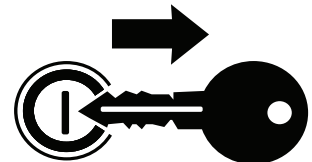

TIRE SAFETY

- Tire changing can be dangerous and must be performed by trained personnel using the correct tools and equipment.
- Always maintain correct tire pressure. Do not inflate tires above recommended pressures shown in the Operator's Manual.
- When inflating tires, use a clip-on chuck and extension hose long enough to allow you to stand to one side and NOT in front of or over the tire assembly. Use a safety cage if available.
- Securely support the implement when changing a wheel.
- When removing and installing wheels, use wheel handling equipment adequate for the weight involved.
- Make sure wheel bolts have been tightened to the specified torque.
- Some attachments may have foam or sealant inside them and must be disposed of properly.



OPERATION SAFETY

- Stay alert for holes, rocks, and roots in the terrain and other hidden hazards. Keep away from drop-offs.
- Stop implement immediately upon striking an obstruction. Turn engine off, remove key, inspect and repair any damage before resuming operation.
- Never operate tractor and implement under trees with low hanging limbs. Operators can be knocked off the tractor and then run over by implement.

TRANSPORT SAFELY

- Comply with federal, state, and local laws.
- Use towing vehicle and trailer of adequate size and capacity. Secure equipment towed on a trailer with tie downs and chains.
- Sudden braking can cause a towed trailer to swerve and upset. Reduce speed if trailer is not equipped with brakes.
- Avoid contact with any overhead utility lines or electrically charged conductors.
- Always drive with load on end of loader arms low to the ground.
- Always drive straight up and down steep inclines with heavy end of a tow vehicle with loader attachment on the "uphill" side.
- Engage park brake when stopped on an incline.
- Maximum transport speed for an attached equipment is 20 mph. **DO NOT EXCEED.** Never travel at a speed which does not allow adequate control of steering and stopping. Some rough terrains require a slower speed.
- As a guideline, use the following maximum speed weight ratios for attached equipment:
 - 20 mph** when weight of attached equipment is less than or equal to the weight of machine towing the equipment.
 - 10 mph** when weight of attached equipment exceeds weight of machine towing equipment but not more than double the weight.

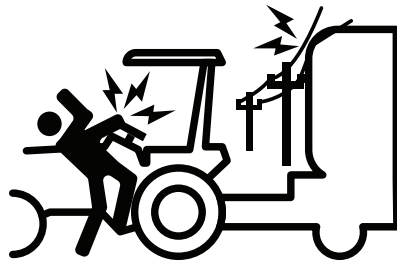

IMPORTANT: Do not tow a load that is more than double the weight of the vehicle towing the load.



PRACTICE SAFE MAINTENANCE

- Understand procedure before doing work. Refer to the Operator's Manual for additional information.
- Work on a level surface in a clean dry area that is well-lit.
- Lower implement to the ground and follow all shutdown procedures before leaving the operator's seat to perform maintenance.
- Do not work under any hydraulic supported equipment. It can settle, suddenly leak down, or be lowered accidentally. If it is necessary to work under the equipment, securely support it with stands or suitable blocking beforehand.
- Use properly grounded electrical outlets and tools.
- Use correct tools and equipment for the job that are in good condition.
- Allow equipment to cool before working on it.
- Disconnect battery ground cable (-) before servicing or adjusting electrical systems or before welding on implement.
- Inspect all parts. Make certain parts are in good condition & installed properly.
- Replace parts on this implement with genuine ABI Attachments parts only.
- Do not alter this implement in a way which will adversely affect its performance.
- Do not grease or oil implement while it is in operation.
- Remove buildup of grease, oil, or debris.
- Always make sure any material and waste products from the repair and maintenance of the implement are properly collected and disposed.
- Remove all tools and unused parts before operation.



PREPARE FOR EMERGENCIES

- Be prepared if a fire starts.
- Keep a first aid kit and fire extinguisher handy.
- Keep emergency numbers for doctor, ambulance, hospital and fire department near phone.



USE SAFETY LIGHTS AND DEVICES

- Slow moving tractors, skid steers, self-propelled machines, and towed equipment can create a hazard when driven on public roads. They are difficult to see, especially at night. Use the Slow Moving Vehicle sign (SMV) when on public roads.
- Flashing warning lights and turn signals are recommended whenever driving on public roads.



KEEP RIDERS OFF MACHINERY

- Never carry riders on tractor or implement.
- Riders obstruct operator's view and interfere with the control of the tow vehicle.
- Riders can be struck by objects or thrown from the equipment.
- Never use tractor or implement to lift or transport riders.

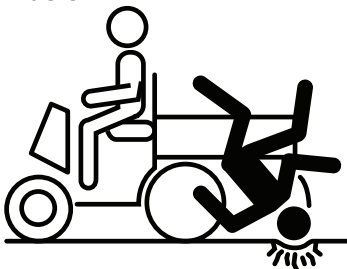

WEAR PERSONAL PROTECTION EQUIPMENT

- Wear protective clothing and equipment appropriate for the job such as safety shoes, safety glasses, hard hat, and ear plugs.
- Clothing should fit snug without fringes and pull strings to avoid entanglement with moving parts.
- Prolonged exposure to loud noise can cause hearing impairment or hearing loss. Wear suitable hearing protection such as earmuffs or earplugs.
- Operating equipment safely requires the operator's full attention. Avoid wearing headphones while operating equipment.

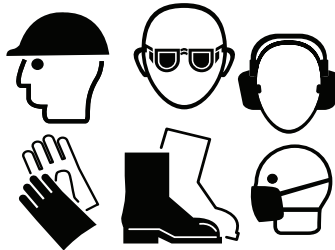

USE SEAT BELT AND ROPS

- ABI Attachments recommends the use of a CAB or roll-over protective structures (ROPS) and seat belt in almost all tow vehicles. Combination of a CAB or ROPS and seat belt will reduce the risk of serious injury or death if the tow vehicle should be upset.
- If ROPS is in the locked-up position, fasten seat belt snugly and securely to help protect against serious injury or death from falling and machine overturn.

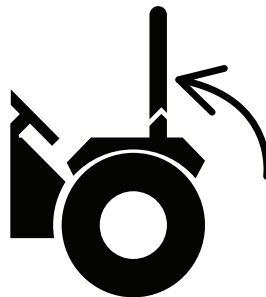

AVOID HIGH PRESSURE FLUIDS HAZARD

- Escaping fluid under pressure can penetrate the skin causing serious injury.
- Before disconnecting hydraulic lines or performing work on the hydraulic system, be sure to release all residual pressure.
- Make sure all hydraulic fluid connections are tight and all hydraulic hoses and lines are in good condition before applying pressure to the system.
- Use a piece of paper or cardboard, NOT BODY PARTS, to check for suspected leaks.
- Wear protective gloves and safety glasses or goggles when working with hydraulic systems.
- DO NOT DELAY. If an accident occurs, see a doctor familiar with this type of injury immediately. Any fluid injected into the skin or eyes must be treated within a few hours or gangrene may result.



AVOID UNDERGROUND UTILITIES

- **Dig Safe, Call 811 (USA).**
- Always contact your local utility companies (electrical, telephone, gas, water, sewer, and others) before digging so that they may mark the location of any underground services in the area.
- Be sure to ask how close you can work to the marks they positioned.



UNCRATING & INITIAL SETUP:

SETUP INSTRUCTIONS:

TOOLS NEEDED:

- GLOVES
- SAFETY GLASSES
- HAMMER
- CROWBAR
- TIN SNIPS
- 9/16" WRENCH AND SOCKET WRENCH
 - 3" SOCKET EXTENSION RECOMMENDED

REMOVING FROM SHIPPING CRATE:

1. Disassemble shipping crate.
2. Lift Tongue/Hitch assembly out of Classic Spreader. Remove Tongue/Hitch assembly and 2 notched plates (notched plates will only be included on the 50 and 65 classic spreaders) from protective wrapping. Set the 2 notched plates aside.

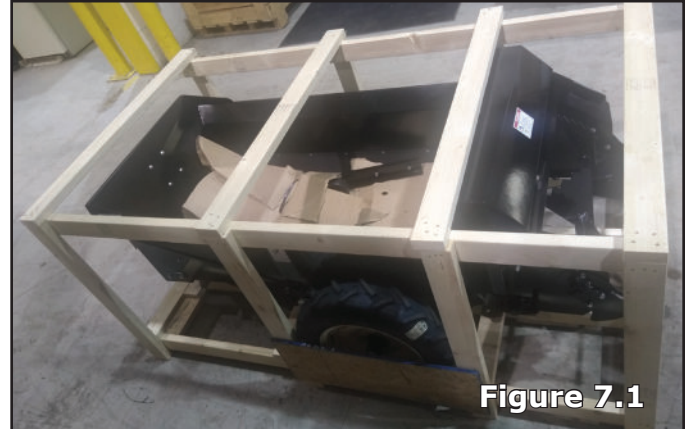

Figure 7.1

ASSEMBLE TONGUE/HITCH TO CHASSIS:

1. Slide "V" shaped tongue frame under the chassis far enough to lift the tongue frame up into the "V" shaped welded "C" channels on the chassis then pull the tongue frame toward the front of the chassis until the 4 bolt holes (2 on each side) in the tongue frame line up with the 4 bolt holes (2 on each side) in the chassis "C" channels. Insert supplied carriage bolts into the 4 holes from the outside of frame. **(Figure 7.2).**
2. On inside of frame, slide supplied split washer onto bolts then thread on supplied nuts and tighten using 9/16" socket (use socket extension if need be).

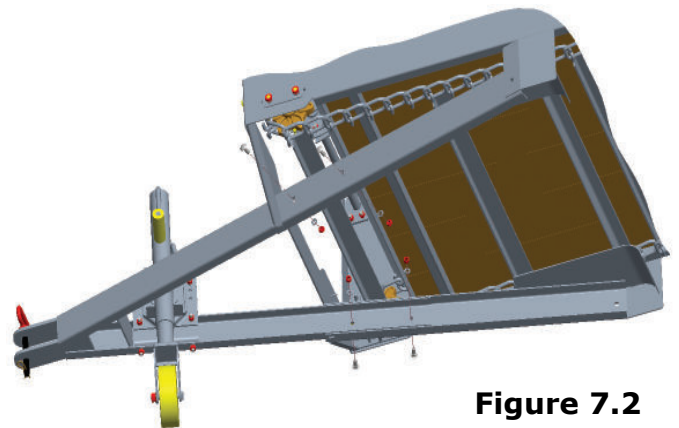

Figure 7.2

ATTACHING WEB EXTENSION SPRING:

1. The Web Extension Spring, behind the right wheel, is detached to prevent the Tongue and Hitch assembly from potentially jamming into the Widespread assembly during shipping.
2. Remove the tag and wire from the Web Extension Spring.
3. Grab Web Extension Spring and pull spring toward Spring Bracket. Slide looped portion of spring onto hook portion on Spring Bracket as shown.

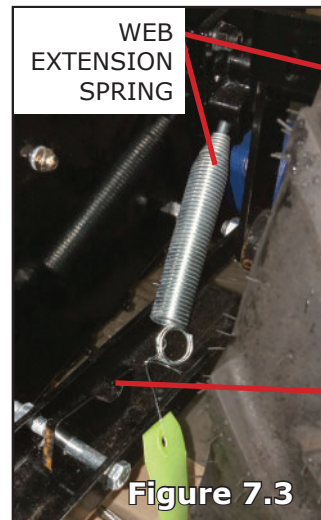

Figure 7.3

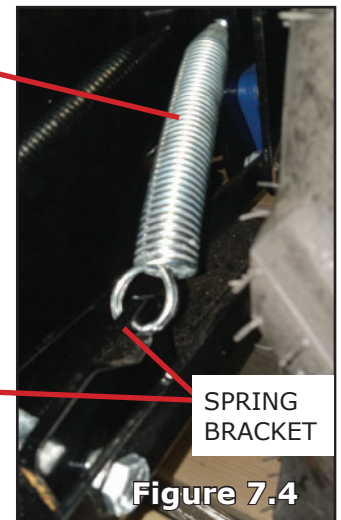
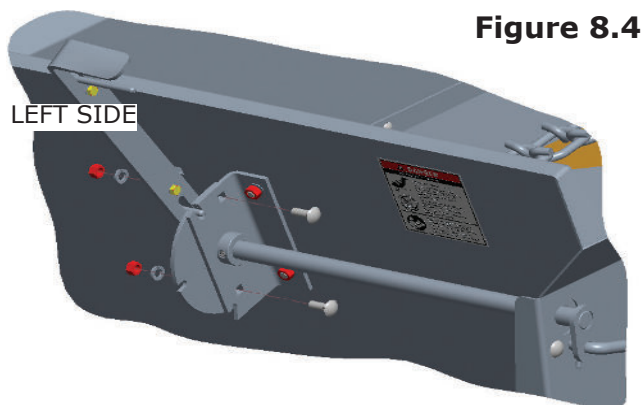
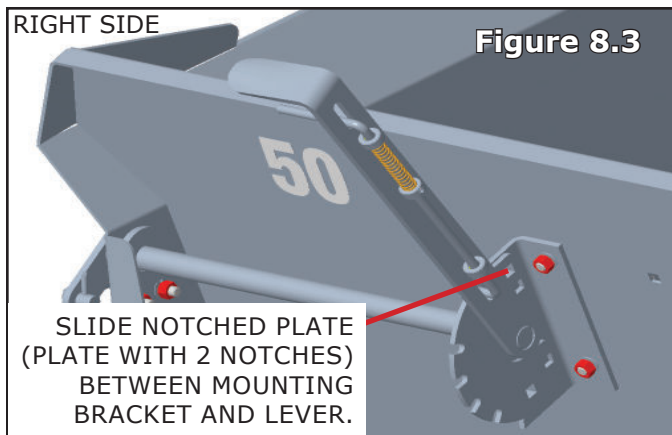
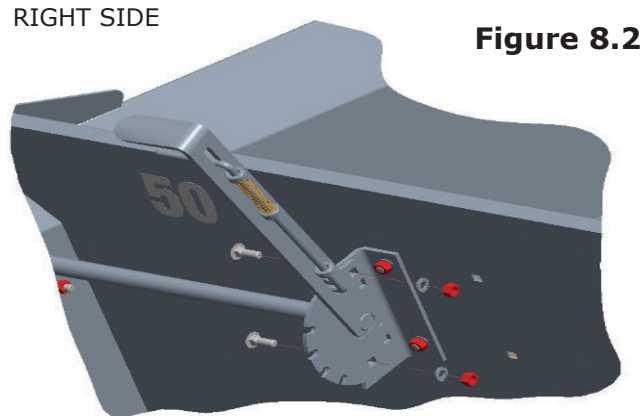
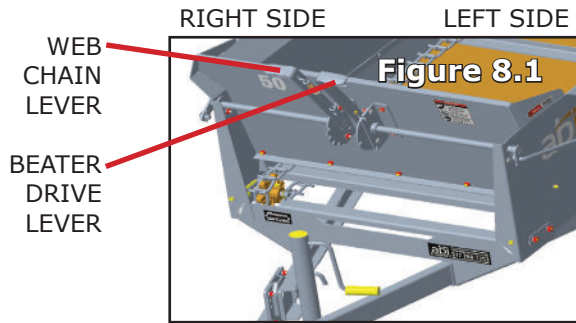

Figure 7.4

UNCRATING & INITIAL SETUP (CONT'D):



ASSEMBLE NOTCHED PLATE TO LEVERS:

The terms "left" and "right" designate the side of the spreader from the view point of sitting in the tractor seat facing forward.

This section is for 50 & 65 cubic foot spreaders only. Owners of the 25 cubic foot spreader can skip this section.

1. The notched plate that mounts to the Web Chain Conveyor Drive Lever (right side) has 5 notches. The deepest notch on the plate should be to the top of the plate when mounted to the unit. The plate slides in between the handle and mounting bracket (**Figure 8.3**).
2. Line up square holes in plate with square holes in mounting bracket (**Figure 8.2**).
3. Use (2) 3/8-16 x 1" long carriage bolts along with 3/8" split washers and 3/8-16 nuts (hardware supplied). Tighten using a 9/16" socket.
4. The notched plate that mounts to the Beater Drive Lever (left side) has (2) notches. The plate slides in between the handle and mounting bracket (**Figure 8.5**).
5. Line up square holes in plate with square holes in mounting bracket (**Figure 8.4**).
6. Use (2) 3/8-16 x 1" long carriage bolts along with 3/8" split washers and 3/8-16 nuts. Tighten using a 9/16" socket.

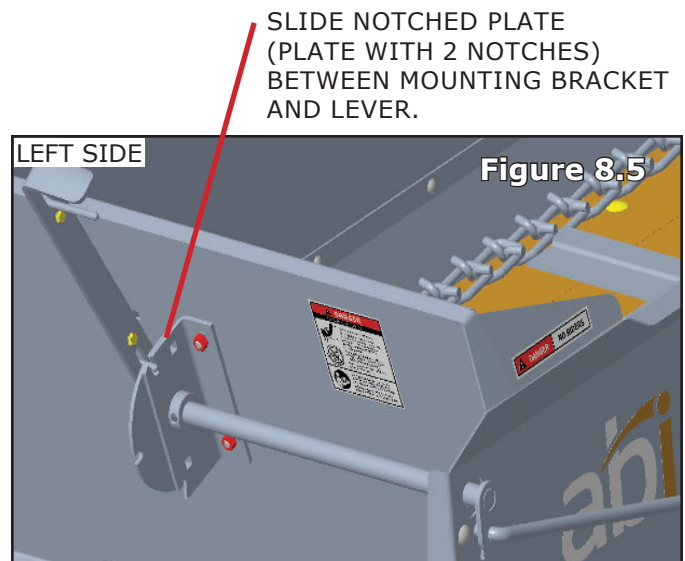

OPERATIONS GUIDE:

HITCH OPERATION:

DO NOT pin the hitch to a draw bar that is attached to a 3pt hitch, this may cause the classic spreader to jackknife when backing up and damage the unit. Please use a straight draw bar mounted directly to the tractor (**Figure 9.1**).

WHEEL JACK OPERATION:

When Spreader is not attached to tow vehicle, the wheel jack can be in vertical position to help maneuver the spreader (**Figure 9.2**). Use the wheel jack to raise or lower the spreader for easy connection to the tow vehicle. When Spreader is attached to the tow vehicle, the wheel jack must be in horizontal position to avoid damage to the wheel jack. To pivot the jack, pull spring pin out of pin hole and rotate jack. Be sure spring pin snaps back into hole pin after rotating jack (**Figure 9.3**).

NEVER DISCONNECT THE SPREADER FROM THE TOW VEHICLE WITHOUT SECURING THE JACK IN THE VERTICAL POSITION.

The spreader is designed to be used with a pin hitch draw bar that is 10"-12" above the ground.

LOADING THE SPREADER:

When loading the spreader, load the spreader bed from front to rear leaving a small gap in between the end of the manure pile and the beaters and paddles to allow them to start rotating before the manure feeds into them.

ENGAGING THE WEB OR CONVEYOR SPEED:

When facing the spreader from the front, the left lever controls the speed of the web drive. This lever allows how fast the manure will empty and how heavy it is applied. The upper notch is the neutral position and each notch the lever is dropped down, to speed up the flow rate. Squeeze the spring actuated rod attached to the lever to maneuver the lever up and down. ABI suggests using the second (2) or third (3) notch for most applications. Do not engage the web chain when the spreader is in motion. If the lever is in the slowest setting and increase the ground drive speed of the tow vehicle, this will speed up the beater blades while the manure stays in the beater longer to give a better breakdown of the manure. If a really fine manure breakdown is desired, ABI suggests purchasing the optional litter/fine pan for best results. The litter/fine pan arches up at the back of the spreader, smashing the manure even finer between the paddles and the pan.

HITCH SPREADER TO DRAW BAR MOUNTED DIRECTLY TO TRACTOR.

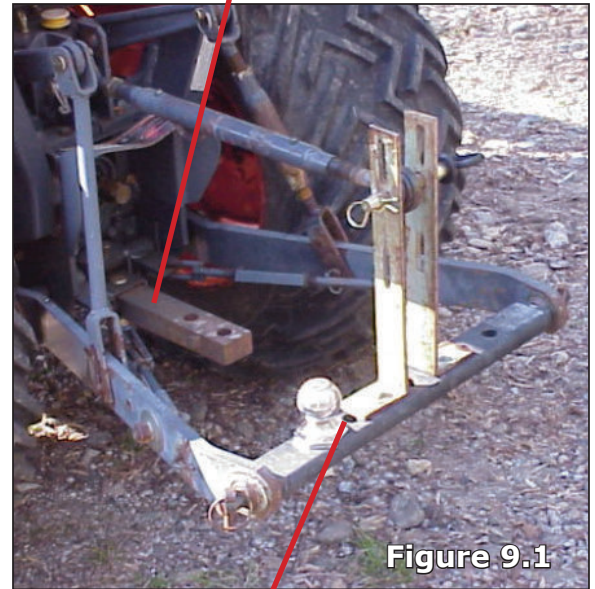

Figure 9.1

DO NOT HITCH SPREADER TO A DRAW BAR THAT IS ATTACHED TO A 3PT HITCH.

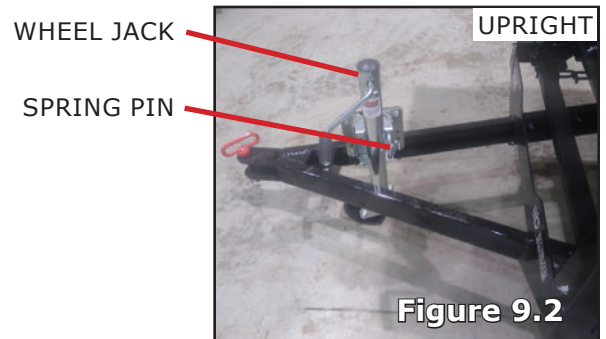

Figure 9.2

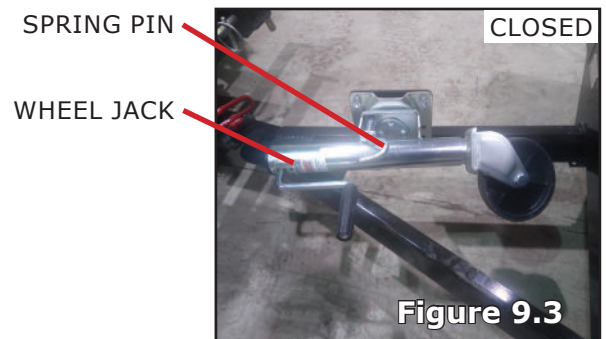

Figure 9.3

OPERATIONS GUIDE (CONTINUED):

ENGAGING THE BEATER:

When facing the spreader from the front, the right lever will allow the beater chain to engage or disengage. The top notch will disengage the chain that drives the beaters. The lower notch will allow the chain to engage into the drive mechanism and start the beaters rotating when the manure spreader is being pulled. Squeeze the spring actuated rod attached to the lever to maneuver the lever up and down. Do not engage the beaters when the spreader is in motion. Damage to the unit will occur.

TROUBLESHOOTING & FAQ'S:

The wet manure is not properly shredding or spreading.

Slow the Web Chain Conveyor if wet manure is bridging or building up.

My wheels "click" when the spreader is going backwards or when in neutral.

The "click" sound is caused by the pawls inside the wheel hub assembly being allowed to freely ratchet around the wheel hubs when moving in reverse to avoid damage to the spreader or when moving forward with the levers in the neutral position so the axle does not engage the web chain and spread manure in unwanted areas.

My wheels are both locked up on my spreader.

First be sure you turned on the beater bars and wide spread on, if not the manure will get packed against the beater bars and stop the unit and you may have to hand shovel enough manure out of the beater bar area for them to turn. Second, if you have a litter pan on the unit it may need cleaned. Build up between the litter pan and the wide spread paddles can cause them to lock up stopping the chains and then the axles from turning.

The manure is not getting cut up enough.

Slow down the web speed to the first or second notch and slightly increase the speed of the tow vehicle. This will cause the web to move slower and the cutting blades to move faster keeping the manure in the beaters or cutters longer to break it up better.

Web chain is not moving or if it is and the manure isn't shredding.

If you load the manure and let it set for a few days during cold temperatures, the manure may freeze the web chain to the bed of the spreader preventing the web chain from moving. It is suggested during the winter to load the manure and spread it right away. Also, during cold temperatures before loading, use a shovel and lift the web chain in the bed area to verify it's not frozen to the bed, then while still empty engage the web chain and run it slowly to verify it works before loading.

There is a high pitch squealing sound when in use.

This is a sign that one or more of the bearings has not been being greased or not greased enough. Grease all the bearings well and see if the noise goes away. If not, please contact the ABI Customer Support Team at (877)788-7253.

The web chain is not tracking perpendicular to the floor boards.

This is a sign that one web chain has "jumped" a web gear most likely due to the chain stretching over time. Lift the web chain that has the most droop under the spreader floor boards up over the front and rear chain gears until the web bars are perpendicular to the floor boards then adjust the web chain(s) as mentioned on **Page 12** under **TIGHTENING THE WEB CHAIN**.



MAINTENANCE: GREASING BEARINGS:

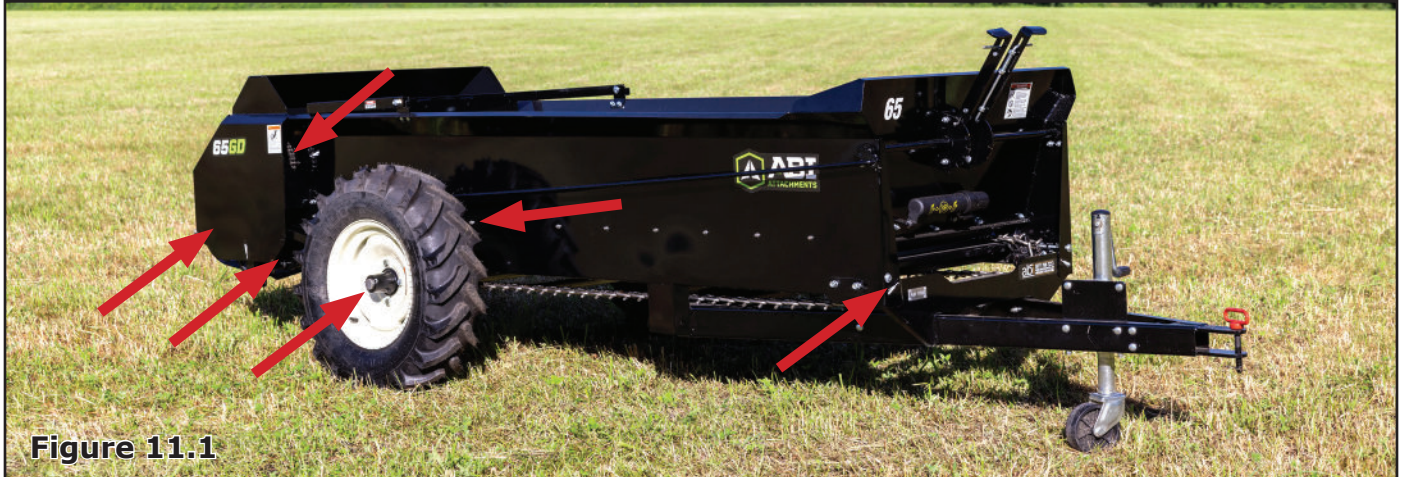

Figure 11.1



Figure 11.2

EACH AREA WHERE THE ARROWS POINT INDICATES WHERE A GREASE POINT IS LOCATED. STICKERS ON THE SPREADER BODY FURTHER INDICATE WHERE GREASE/LUBRICATION POINTS ARE LOCATED.

- The spreader should be greased using a grease gun every 25-30 loads and before storage. Make sure to grease all available grease areas before any period of storage.
- When greasing the hubs on the spreader, use caution to not over grease the hubs. Each hub requires 2-3 full pumps of grease from a manual grease gun every 30-35 loads. Hubs may need to be cleaned out once a year to remove old grease build up. All other grease ports should be greased until the grease oozes out of the bearing to help flush out debris.
- Only grease each axle bearing 1/2 pump once per year.
- Rinse out the bed and Paddles of the ABI Classic Spreader after every use. This will help to ensure longevity of your spreader. It is important to avoid putting excess soil or stones into the spreader. The ABI Classic Spreader was not designed to spread soil or stone. Getting stones caught in the bed will damage the spreader and is not covered under the ABI Classic Spreader warranty.
- Wash the spreader with a power washer periodically and paint any scratches with a semi-gloss black paint to prevent rust.
- Clean off the pawls on the sprockets located on the right side of the spreader after 30-50 loads. Grease from the hubs gather on the pawls and may damage them if not cleaned.

GREASING BEARINGS (CONTINUED):

- Clean chains after every use and oil chains after every 25-30 loads or before periods of storage to prevent any rust. Use SAE 30 or higher rated oil to oil the chains. Use a cloth with oil on it to oil the web chains and drive chains. It is not recommended to pour oil directly in the bed when oiling the web chain.
- Check all nuts and bolts after every 25-30 loads to make sure they are still tight. If any nuts and bolts become loose, please tighten before next use.
- Using a torque wrench, torque your wheel lug nuts to 100 ft/lbs. Recheck after the first use and then check/re-torque every six months, if needed.
- Tire pressure should be 40 psi. on the 25 cu/ft and 50 cu/ft.
- Tire pressure should be 60 psi. on the 65 cu/ft.

ADJUSTMENTS DUE TO WEAR OVER TIME:

TIGHTENING THE WEB CHAIN (CONVEYOR):

There are (2) bolts and (1) adjusting screw on both front lower corners of the spreader to adjust the web chain tension (**Figure 12.1**). Loosen the (2) bolts on both sides of the spreader using a 11/16" wrench (or socket). Use a 9/16" wrench (or socket) to adjust both adjusting screws on the front face of the chassis to the desired tension then re-tighten all four bolts. Both web chains must be adjusted equally. There should be no more than 3"- 3 1/2" of lift in both chains in the middle of the bed. Web chain links can be added or removed if necessary due to the chain stretching or wearing out over time. This should be checked every three months.

CHECK FOR PROPER CHAIN SLACK
WITH 2X4 IN THE MIDDLE OF THE BED

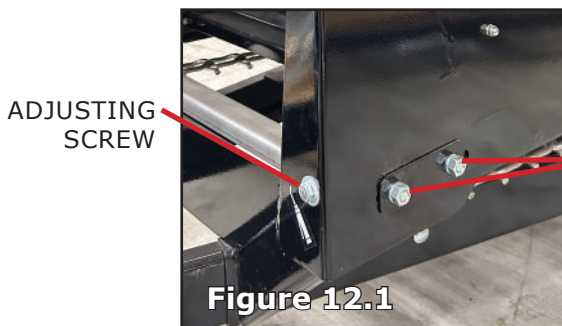

BOLTS TO
SECURE FRONT
WEB CHAIN
GEAR AFTER
ADJUSTING
TENSION

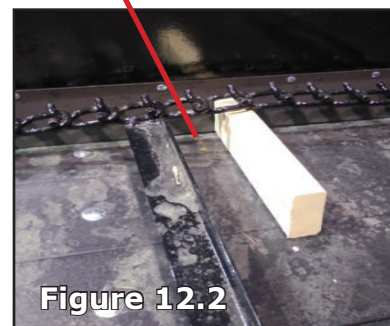

WEB CHAIN LEVER ROD ADJUSTMENT:

The operating lever is attached to a rod that runs to the rear of the spreader to engage the web drive (**Figure 13.1**). The rod may need adjusting as it can develop play over time. For the web drive adjustment, the collar on the rod should be adjusted so there is a 1/4" gap between the star wheel and roller cam (**Figure 13.2**).

Before removing the tire to readjust the rod play, put a wheel block by the jack wheel and by the tire opposite the side to be jacked up. Use safety jacks after jacking up the spreader so the spreader is safely stable. The star wheel can be turned clockwise by hand to line up one of the star wheel lobes next to the roller cam in order to measure the gap between them.

To readjust the rod, move the lever to the disengaged/neutral position (highest position in the notched plate).

Loosen the (2) bolts on the coupler using a 5/16" wrench (**Figure 13.1**) while holding the rod in place and adjust to remove the play in the rod until there is a 1/4" gap between the star wheel and roller cam.

Re-tighten the (2) bolts on the coupler when finished and remount the tire before removing the safety jacks and wheel blocks. Tire lug bolts should be torqued to 100 ft/lbs.

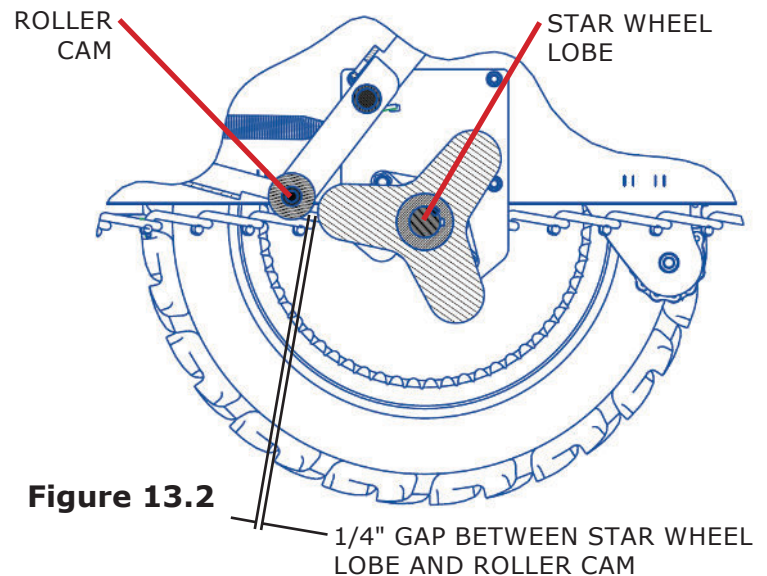
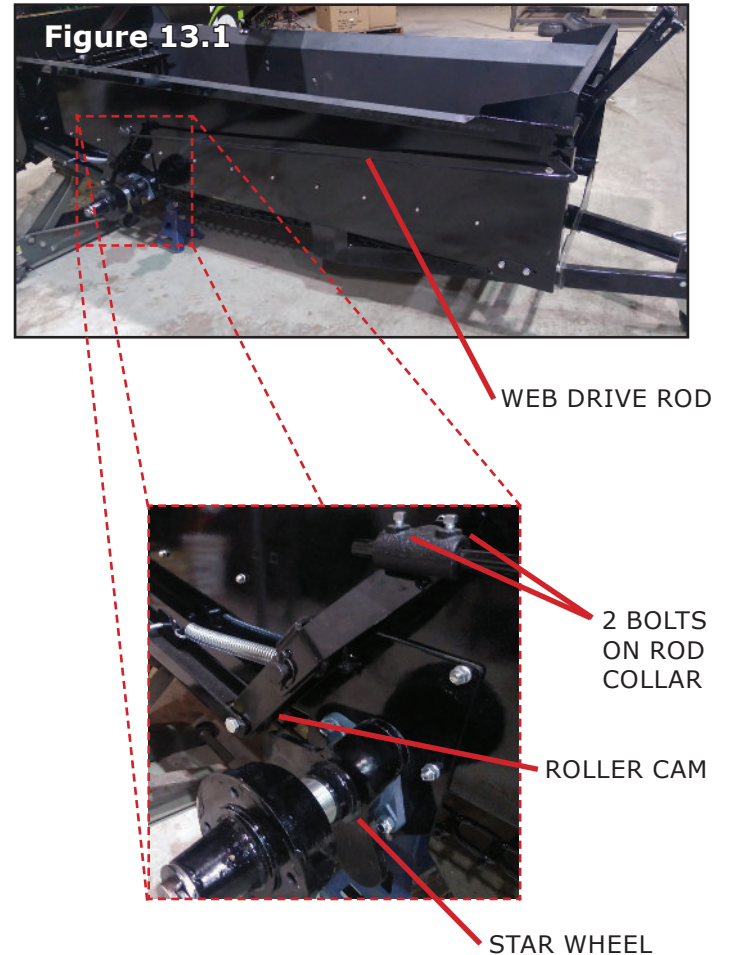

BEATER LEVER ROD ADJUSTMENT:

The operating lever is attached to a rod that runs to the rear of the spreader to engage the beater bar mechanism (**Figure 14.1**). The rod may need adjusting as it can develop play over time. When the lever is in the disengaged/neutral position (highest position in the notched plate), the chain that drives the beater rod mechanism should be slightly clearing the large sprocket (**Figure 14.1**). If the chain is too far from or touching the sprocket, it needs to be adjusted. Before removing the tire to readjust the rod play, put a wheel block by jack wheel and by tire opposite the side to be jacked up. **USE SAFETY JACKS** after jacking up the spreader so the spreader is safely stable. Remove chain guard. To readjust the rod, loosen the 2 bolts on the coupler using a 5/16" wrench (**Figure 14.1**) while holding the rod in place and adjust to remove the play in the rod until the chain is slightly clearing the sprocket. Re-tighten the bolts when finished and remount the tire before removing the safety jacks and wheel blocks. Tire lug bolts should be torqued to 100 ft lbs. Reattach the chain guard.

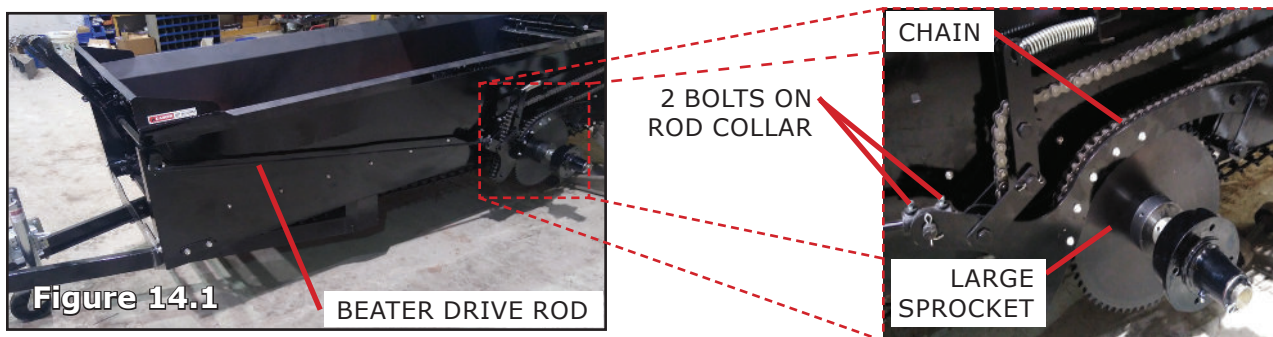

WIDE SPREAD PADDLES CHAIN TIGHTENING:

Over time, the chain that powers the wide spread paddles may get some slack in it and require adjustments. To remove this slack, loosen the two bolts located on the rear sprocket and the 2 bolts mounting the sprocket holder on both sides of the spreader (**Figure 14.2**). Once the bolts have been loosened, have a helper gently pull the whole wide spread wide spread paddles back until most of the slack is taken out of the chain (**Figure 14.2**). Be sure the wide spread paddles are not sitting at an angle after adjustment. Make sure both ends have been adjusted out at the same distance to prevent the wide spread paddles from sitting at an angle, as this may cause damage to the spreader.

Once the slack is taken out, re-tighten the all the bolts. Over tightening the chain may cause damage to chain, sprockets, or other parts of the spreader. A small amount of slack in the chain is acceptable. Reattach chain guard after adjusting is complete and before use.

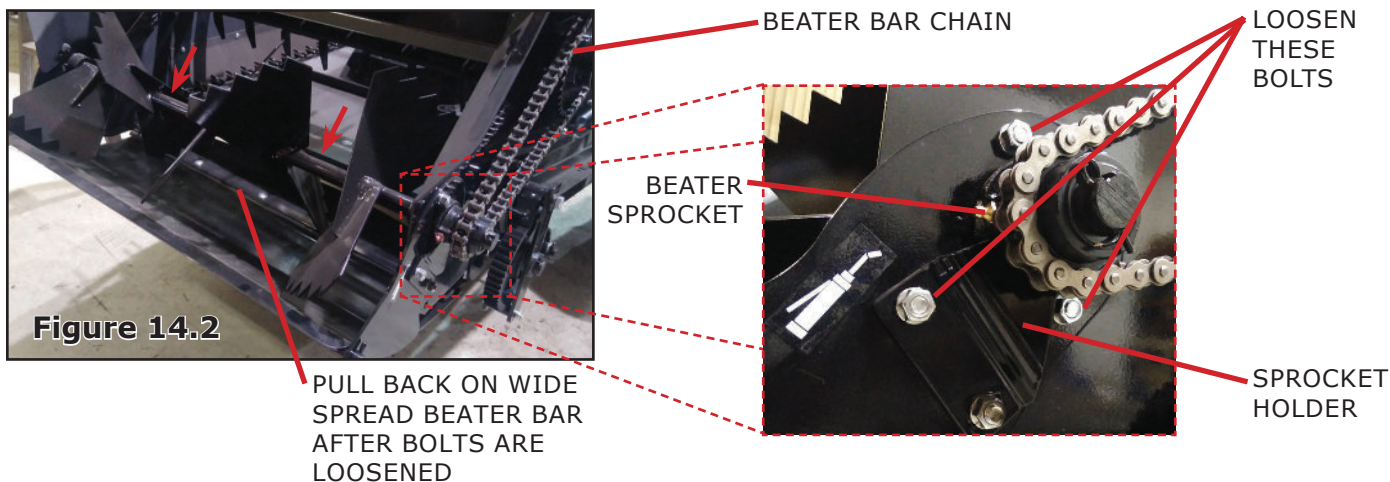

CHAIN ADJUSTMENT:

If over time, either spreader chain stretches enough that any mechanical adjustments do not provide enough tension, then a chain link will need to be removed from the loose chain. Look for the master chain link on the chain (**Figure 15.1 - 15.2**). To remove this link, remove the outer Retaining clip using a screwdriver butted up against the open end of the clip and lightly tap on it with a hammer until it starts to come off (this is a spring clip and if it's hit too hard with the hammer, it may go flying off somewhere). Once the clip is part way loose, use some needle nose pliers and pull it the rest of the way off. After the Retainer clip is off, remove the Keeper plate then pull out the master link (**Figure 15.3**).

Once the chain is un-linked, grind the tips off the next link (**Figure 15.2**) and remove that link. Reinsert the master link, Keeper plate and Retaining clip. Sometimes removing a fall link may result in the chain being too tight to reconnect. If this occurs, an offset or "half (1/2) link" can be purchased at you local farm store or farm equipment dealership.

Mechanical adjustments may be needed to the spreader to reinstall the chain if adjustments were made over time as the chain started to stretch.

See the **Troubleshooting & FAQs** and **Maintenance** sections (**Pages 10 & 11**) if additional adjustments are required.

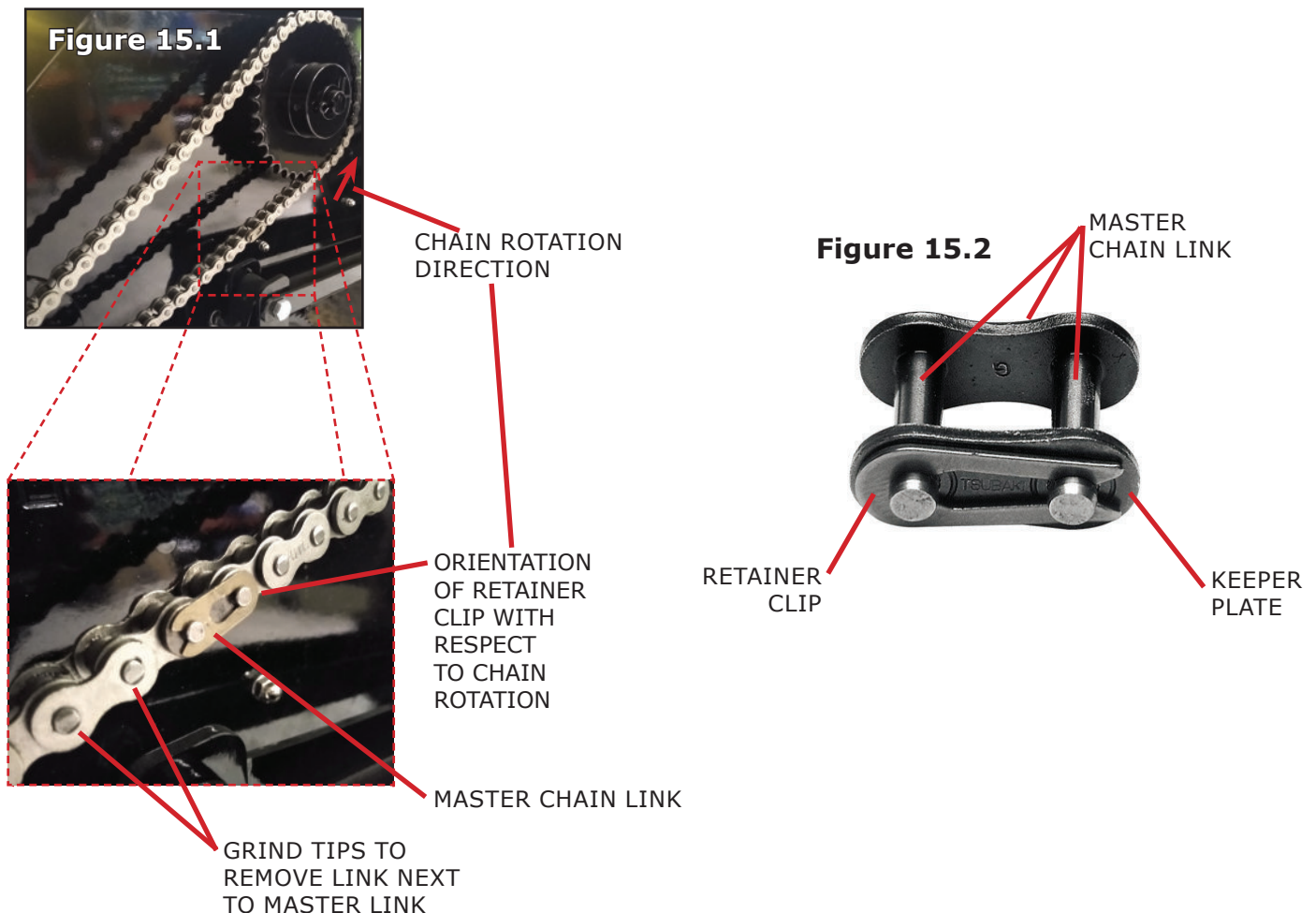

SPECIFICATIONS:

Classic Spreader:	25 cu ft	50 cu ft	65 cu ft
Total Length:	110" (9' 2")	132" (11')	151" (12' 7")
Total Width:	48" (4')	54" (4'6")	58" (4' 10")
Total Height:	43" (3' 7")	43" (3' 7")	54" (4' 6")
Box Length:	60" (5')	76" (6' 4")	84" (7')
Box Width:	28" (2' 4")	35" (2' 11")	35" (2' 11")
Box Height:	16" (1' 4")	19" (1' 7")	19" (1' 7")
Box Flared Width:	33" (2' 9")	40" (3' 4")	40" (3' 4")
Loading Height:	33" (2' 9")	34" (2' 10")	36" (3')
Heaped Capacity:	25 cu ft	50 cu ft	65 cu ft
Struck Capacity:	15 cu ft	29 cu ft	39 cu ft
# of Horses:	Up To 4	Up To 8	Up To 11
Platform:	Compact	Compact	Compact
PTO Driven:	No	No	No
Steel Type:	COR-TEN	COR-TEN	COR-TEN
Steel of Gauge:	12	12	12
# of Beaters:	2	2	2
# of Spreading Paddles:	8	10	10
# of Shredding Blades:	32	32	32
Flow Control Speeds:	4	4	4
Speed Adjustment:	Lever	Lever	Lever
End Gate (optional):	Yes	Yes	Yes
Litter/Fine Pan (optional):	Yes	Yes	Yes
Bed Liner:	Yes	Yes	Yes
Poly Lumber Floor:	Yes	Yes	Yes
Jack Stand:	Dolly Wheel	Dolly Wheel	Dolly Wheel
Tires:	Ag Traction	Ag Traction	Ag Traction
Ratcheting Hubs:	Yes	Yes	Yes
Tractor Type:	Mower	Sub & Compact	Sub & Compact
Min. Horsepower:	18 hp	22 hp	25 hp
Utility Vehicle Type:	ATV, UTV	ATV, UTV	Large ATV, UTV
Min. CC:	350cc	550cc	600cc (4WD)
Unit Weight:	680 lbs	825 lbs	947 lbs
Shipping Weight:	854 lbs	1,001 lbs	1,225 lbs

SLOW MOVING VEHICLE SIGN:

SLOW MOVING VEHICLE SIGN REQUIRED WHEN TRAVELING ON PUBLIC ROADWAYS.

Since June 2025, slow moving vehicle signs have been packaged inside the Manure Spreader (**Figure 17.2**). If you purchased a Manure Spreader before June 2025, you can obtain a slow moving vehicle sign and mounting bracket from any local farm store.

Remove the slow moving vehicle sign from the cardboard package and install it onto the bracket on the back of the Manure Spreader (**Figure 17.3**).

The slow moving vehicle sign (**Figure 17.1**) should be removed, once the manure spreader is no longer on a public roadway, to spread manure. Failure to remove the slow moving vehicle sign while spreading will cause a buildup of manure around it.

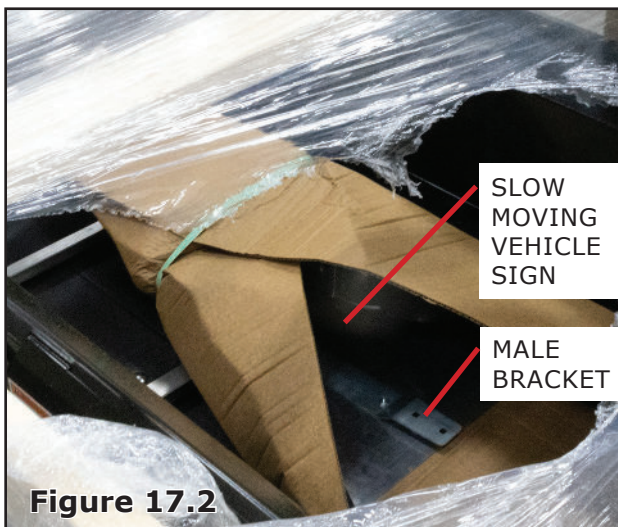
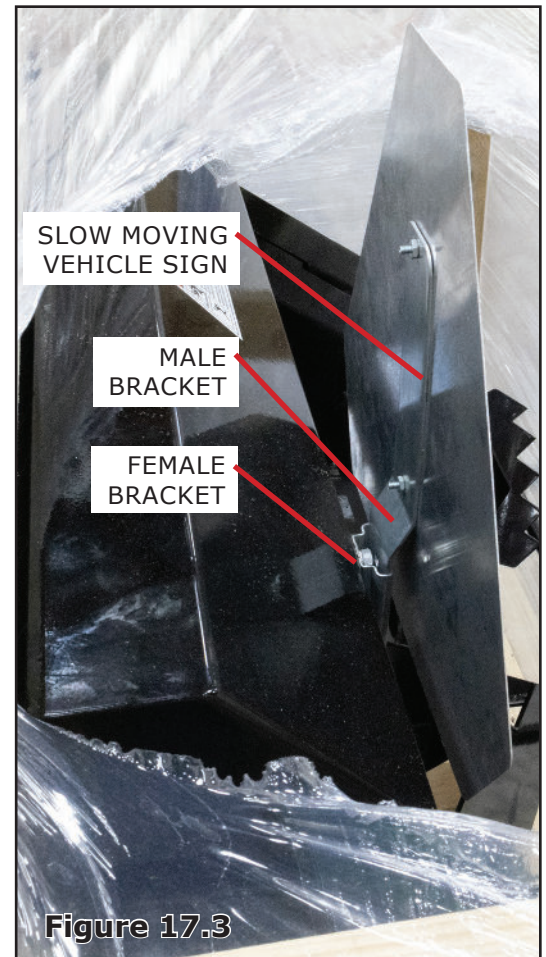

REPLACEMENT PARTS:

Some components are considered wear parts and will need to be replaced as they wear out from use. Below are parts descriptions, and photos, to assist you in ordering the correct wear part. To place an order, please contact the ABI Support department at (877)788-7253.

PARTS DESCRIPTION:

CLASSIC SPREADER GROUND DRIVE:

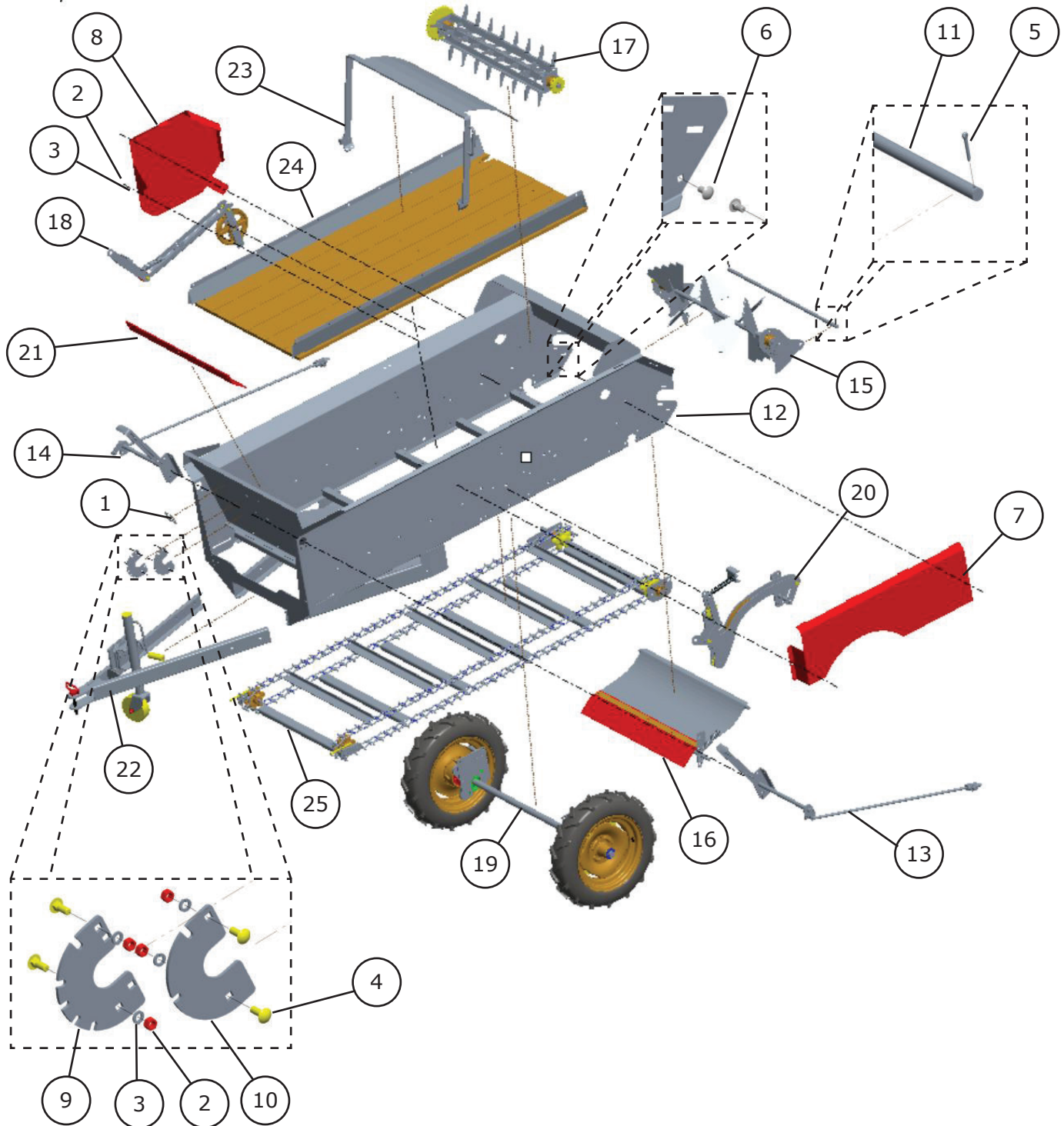

CLASSIC SPREADER GROUND DRIVE (CONT'D):

ITEM	PART #	DESCRIPTION	QTY
1	10-11010	LBL: NUMERAL 25	1
1	10-10985	LBL: NUMERAL 50	1
1	10-11019	LBL: NUMERAL 65	1
2	10-20130	3/8" HEX NUT	10
3	10-20133	3/8" LOCK WASHER	10
4	10-20379	3/8 x 1" CARRIAGE BOLT	4
5	10-20424	3/16 X 1-1/4 COTTER PIN	2
6	10-20475	3/8 X 3/4" CARRIAGE BOLT	6
7	10-32022	MAIN CHAIN SHIELD (#25)	1
7	10-31905	MAIN CHAIN SHIELD (#50)	1
7	10-32072	MAIN CHAIN SHIELD (#65)	1
8	10-32023	WEB DRIVE SHIELD (#25)	1
8	10-31906	WEB DRIVE SHIELD (#50/#65)	1
9		WEB NOTCH PLATE (#25)	1
9	10-31941	WEB NOTCH PLATE (#50/#65)	1
10		CHAIN NOTCH PLATE (#25)	1
10	10-31942	CHAIN NOTCH PLATE (#50/#65)	1
11	10-32061	REAR GUARD (#25)	1
11	10-32350	REAR GUARD (#50/65)	1
12	10-40590	WLDMT: CHASSIS, 25	1
12	10-40578	WLDMT: CHASSIS, 50	1
12	10-40593	WLDMT: CHASSIS, 65	1
13	10-90480	ASM: CHAIN DRIVE CONTROL LEVER (#25)	1
13	10-90461	ASM: CHAIN DRIVE CONTROL LEVER (#50)	1
13	10-90494	ASM: CHAIN DRIVE CONTROL LEVER (#65)	1
14	10-90481	ASM: WEB DRIVE CONTROL LEVER (#25)	1
14	10-90462	ASM: WEB DRIVE CONTROL LEVER (#50)	1
14	10-90495	ASM: WEB DRIVE CONTROL LEVER (#65)	1
15	10-90482	ASM: WIDESPREAD (#25)	1
15	10-90464	ASM: WIDESPREAD (#50/#65)	1

ITEM	PART #	DESCRIPTION	QTY
16	10-90483	ASM: LITTER/FINE PAN (#25) (OPTIONAL)	1
16	10-90465	ASM: LITTER/FINE PAN (#50/#65) (OPTIONAL)	1
17	10-90484	ASM: BEATER (#25)	1
17	10-90466	ASM: BEATER (#50/#65)	1
18	10-90486	ASM: WEB DRIVE (#25)	1
18	10-90468	ASM: WEB DRIVE (#50)	1
18	10-90497	ASM: WEB DRIVE (#65)	1
19	10-90487	ASM: WHEEL AND AXLE (#25)	1
19	10-90469	ASM: WHEEL AND AXLE (#50)	1
19	10-90498	ASM: WHEEL AND AXLE (#65)	1
20	10-90513	ASM: CHAIN LIFT ARM (#25)	1
20	10-90472	ASM: CHAIN LIFT ARM (#50)	1
20	10-90514	ASM: CHAIN LIFT ARM (#65)	1
21	10-90488	ASM: FRONT RUBBER FLAP (#25)	1
21	10-90473	ASM: FRONT RUBBER FLAP (#50/#65)	1
22	10-90507	ASM: HITCH/WHEEL JACK (#25)	1
22	10-90479	ASM: HITCH/WHEEL JACK (#50/#65)	1
23	10-90508	ASM: END GATE (#25) (OPTIONAL)	1
23	10-90499	ASM: END GATE (#50/#65) (OPTIONAL)	1
24	10-90509	ASM: FLOOR BOARDS AND SIDE RAILS (#25)	1
24	10-90500	ASM: FLOOR BOARDS AND SIDE RAILS (#50)	1
24	10-90511	ASM: FLOOR BOARDS AND SIDE RAILS (#65)	1
25	10-90510	ASM: WEB CHAIN AND GEARS (#25)	2
25	10-90501	ASM: WEB CHAIN AND GEARS (#50)	2
25	10-90512	ASM: WEB CHAIN AND GEARS (#65)	2

ASM: HITCH/WHEEL JACK:

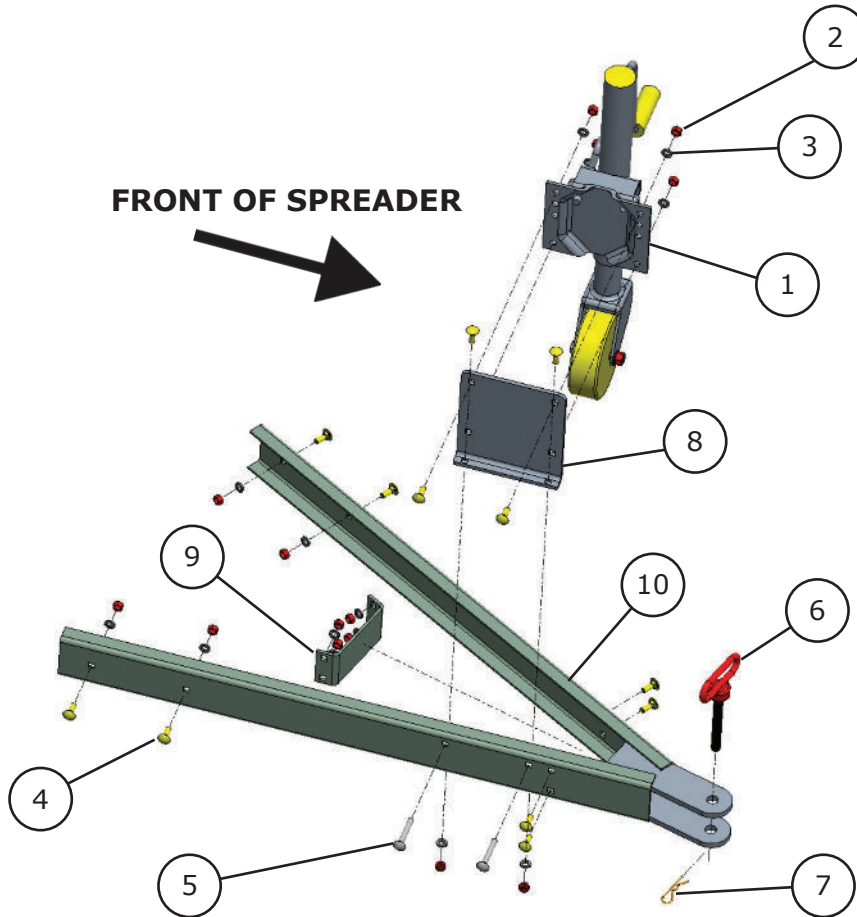

ITEM	PART #	DESCRIPTION	QTY
1	10-11009	RAM SIDE MOUNT SWIVEL WHEEL JACK 1200 LBS	1
2	10-20130	3/8-16 HEX NUT	14
3	10-20133	3/8" LOCK WASHER	14
4	10-20379	CARRIAGE BOLT 3/8-16 X 1": ZINC GR 5	12
5	10-20483	CARRIAGE BOLT 3/8-16 X 2-1/4": ZINC GR 5	2
6	10-20485	T HANDLE HITCH PIN	1
7	10-20486	HITCH PIN SAFETY CLIP 1/8" X 2-5/8"	1
8	10-31940	WHEEL JACK MOUNT PLATE	1
9	10-31958	A-FRAME SUPPORT PLATE (#50/65)	1
10	10-40589	WLDMT: BOLT ON HITCH (#25)	1
10	10-40577	WLDMT: BOLT ON HITCH (#50/#65)	1

ASM: FRONT RUBBER FLAP:

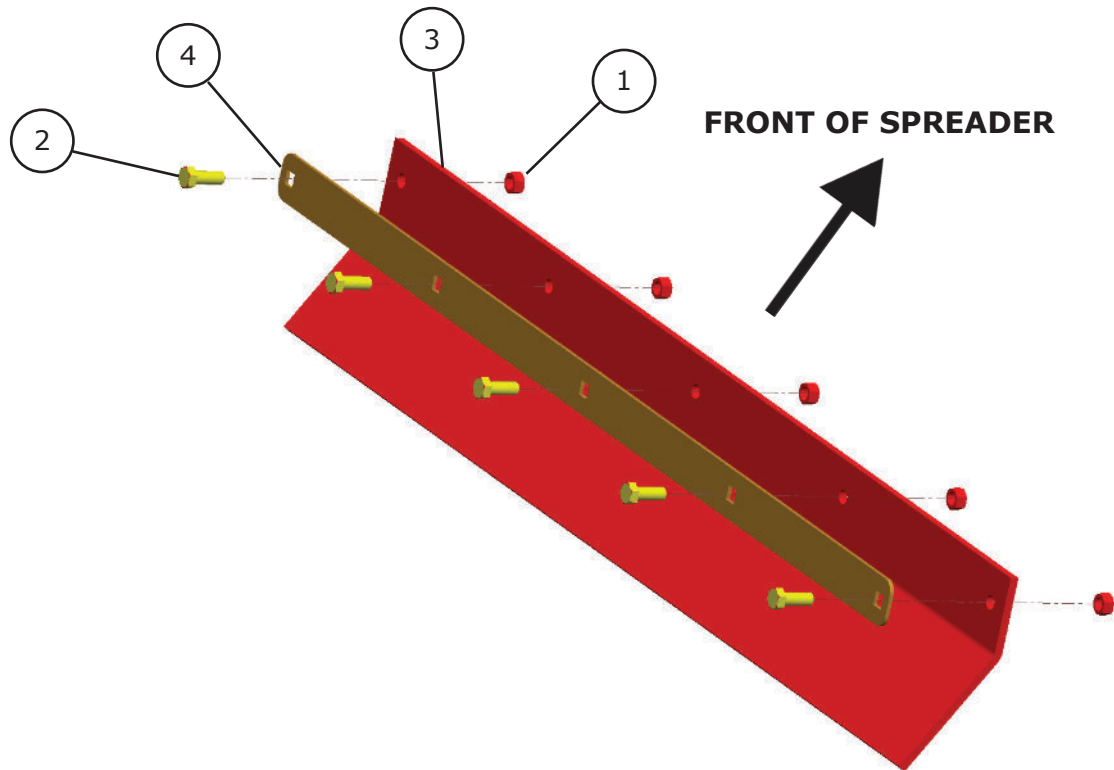

ITEM	PART #	DESCRIPTION	QTY
1	10-20130	3/8-16 HEX NUT	5
2	10-20279	3/8-16 X 1" HEX BOLT	5
3	10-32035	FRONT RUBBER FLAP (#25)	1
3	10-31935	FRONT RUBBER FLAP (#50/#65)	1
4	10-32036	RUBBER FLAP PLATE (#25)	1
4	10-31936	RUBBER FLAP PLATE (#50/#65)	1

ASM: CHAIN DRIVE CONTROL LEVER:

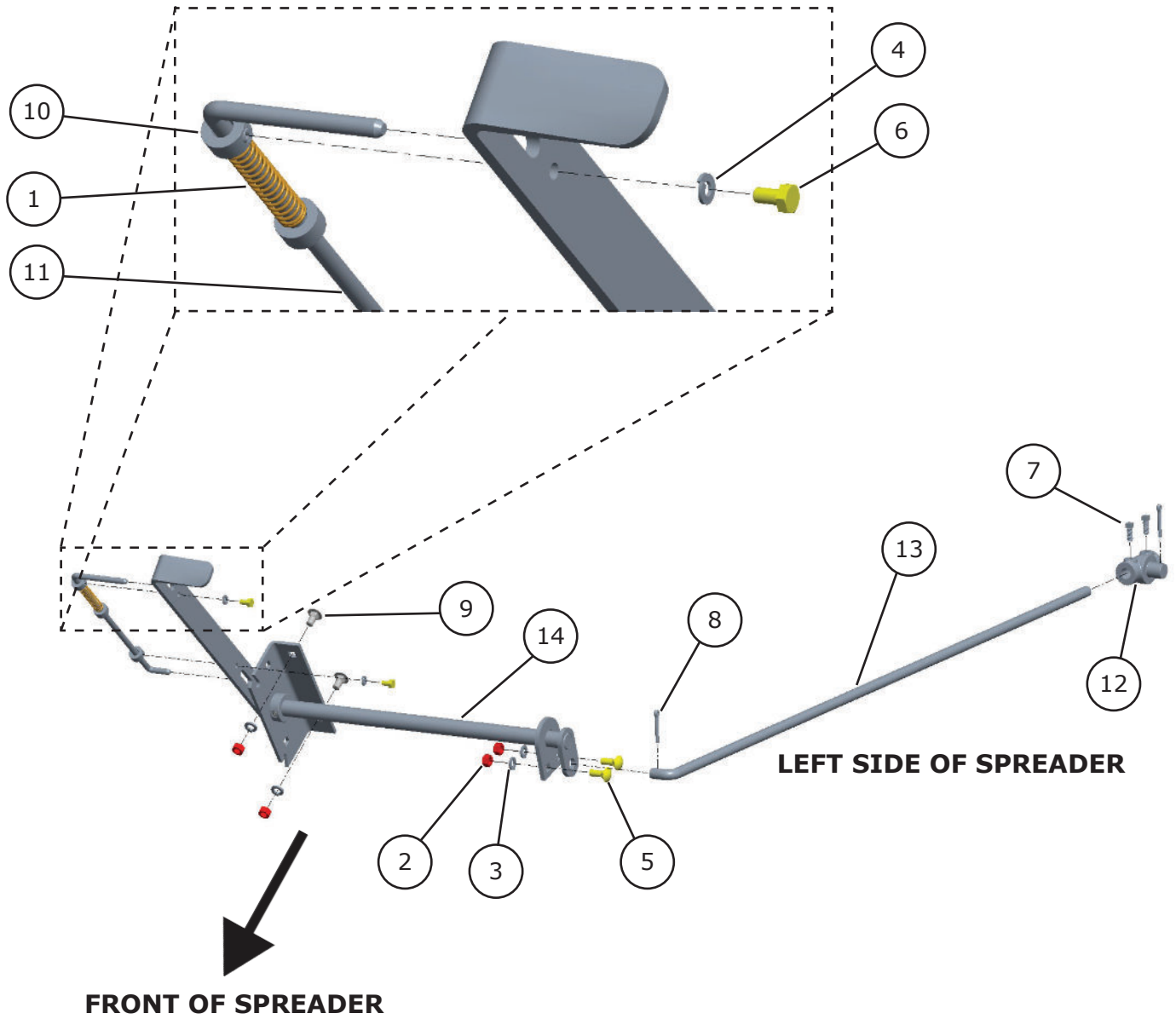

ASM: CHAIN DRIVE CONTROL LEVER (CONT'D):

ITEM	PART #	DESCRIPTION	QTY
1	10-10955	25/50/65 LEVER HANDLE SPRING	1
2	10-20130	3/8" HEX NUT	4
3	10-20133	3/8" LOCK WASHER	4
4	10-20277	1/4" LOCK WASHER	1
5	10-20379	3/8" X 1" CARRIAGE BOLT	2
6	10-20420	1/4 X 1/2" HEX BOLT	1
7	10-20423	5/16 X 3/4" SQUARE HEAD SET SCREW	2
8	10-20424	3/16 X 1-1/4" COTTER PIN	2
9	10-20475	3/8" X 3/4" CARRIAGE BOLT	2
10	10-20547	3/8" SHAFT COLLAR	1
11	10-31909	LEVER HANDLE ROD	1
12	10-31916	DOUBLE SET TEE COLLAR	1
13	10-32030	9/16 X 37" #25 LEVER ROD, BEATER DRIVE	1
13	10-31917	9/16 X 42" #50 LEVER ROD, BEATER DRIVE	1
13	10-32064	9/16 X 56" #65 LEVER ROD, BEATER DRIVE	1
14	10-40583	#25 CHAIN LEVER ASSEMBLY	1
14	10-40554	#50/65 CHAIN LEVER ASSEMBLY	1

ASM: WEB DRIVE CONTROL LEVER:

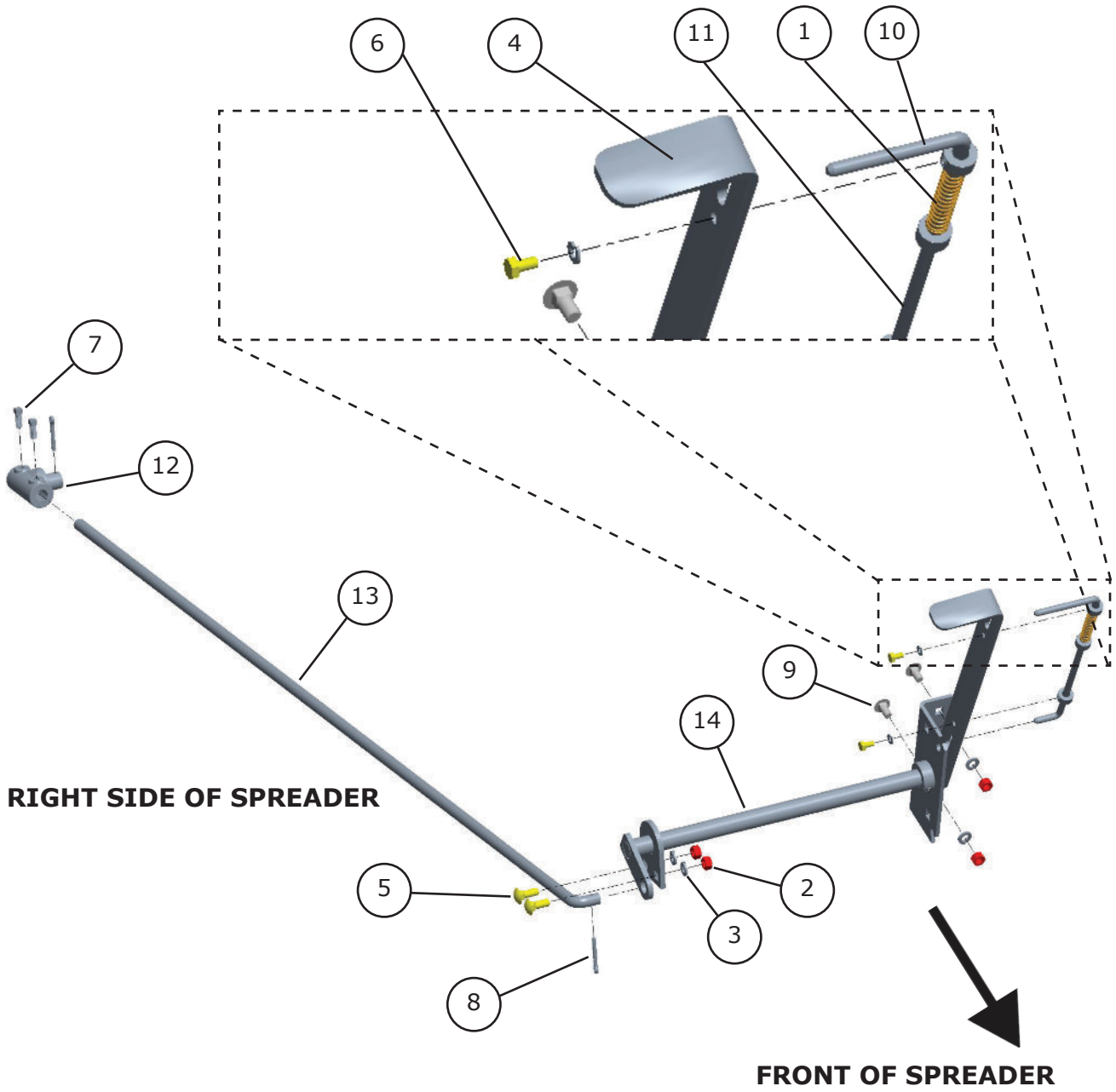

ASM: WEB DRIVE CONTROL LEVER (CONT'D):

ITEM	PART #	DESCRIPTION	QTY
1	10-10955	25/50/65 LEVER HANDLE SPRING	1
2	10-20130	3/8-16 HEX NUT	4
3	10-20133	3/8" LOCK WASHER	4
4	10-20277	1/4" LOCK WASHER	2
5	10-20379	3/8-16 X 1" CARRIAGE BOLT	2
6	10-20420	1/4-20 X 1/2" HEX BOLT	2
7	10-20423	5/16-18 X 3/4" SQUARE HEAD SET SCREW	2
8	10-20424	3/16" X 1-1/4" COTTER PIN	2
9	10-20475	3/8-16 X 3/4" CARRIAGE BOLT	2
10	10-20547	3/8" SHAFT COLLAR	3
11	10-31909	LEVER HANDLE ROD	1
12	10-31916	DOUBLE SET TEE COLLAR	1
13	10-32032	9/16 X 37" #25 LEVER ROD, WEB DRIVE	1
13	10-31920	9/16 X 42" #50 LEVER ROD, WEB DRIVE	1
13	10-32065	9/16 X 56" #65 LEVER ROD, WEB DRIVE	1
14	10-40584	#25 WEB LEVER ASSEMBLY	1
14	10-40556	#50/65 WEB LEVER ASSEMBLY	1

ASM: FLOOR BOARDS AND SIDE RAILS:

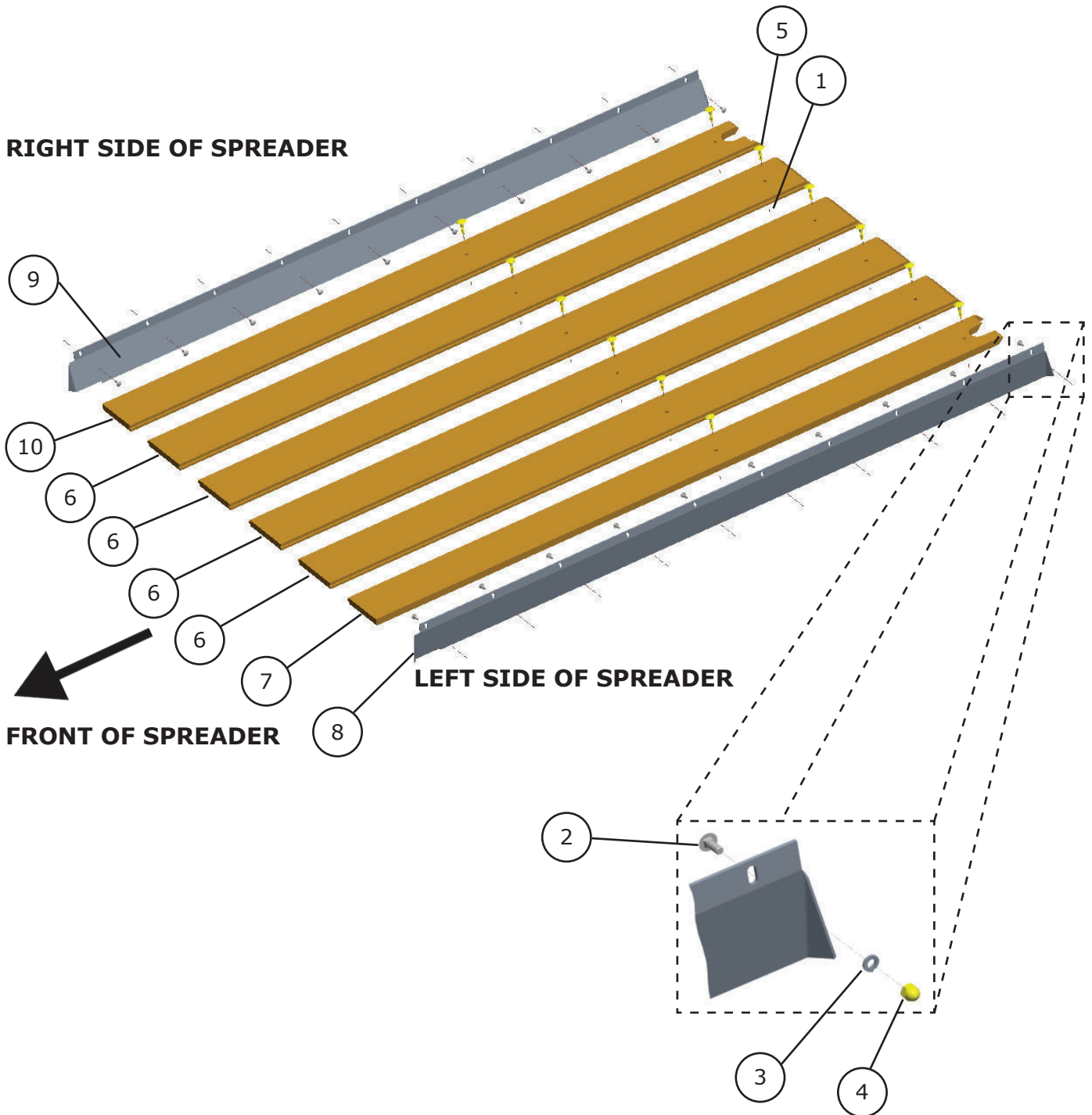

ASM: FLOOR BOARDS AND SIDE RAILS (CONT'D):

ITEM	PART #	DESCRIPTION	QTY
1	10-20126	5/16-18 HEX NUT	12
2	10-20476	1/4-20 X 5/8" CARRIAGE BOLT	20
3	10-20477	7/16" LOCK WASHER	20
4	10-20478	1/4-20 CAP NUT	20
5	10-20484	5/16-18 X 1-1/2" STEP BOLT	12
6	10-32042	3/4" X 6 X 59" L, POLY FLOOR BOARD (#25)	3
6	10-31987	3/4" X 6 X 76" L, POLY FLOOR BOARD (#50)	4
6	10-32066	3/4" X 6 X 98" L, POLY FLOOR BOARD (#65)	5
7	10-32043	3/4" X 6 X 58-13/16" L, POLY FLOOR BOARD (MODIFIED LEFT) (#25)	1
7	10-31988	3/4" X 6 X 75-1/4" L, POLY FLOOR BOARD (MODIFIED LEFT) (#50)	1
7	10-32068	3/4" X 6 X 97-7/8" L, POLY FLOOR BOARD (MODIFIED LEFT) (#65)	1
8	10-32044	FLOOR CORNER PANEL, LEFT (#25)	1
8	10-31989	FLOOR CORNER PANEL, LEFT (#50)	1
8	10-32069	FLOOR CORNER PANEL, LEFT (#65)	1
9	10-32045	FLOOR CORNER PANEL, RIGHT (#25)	1
9	10-31990	FLOOR CORNER PANEL, RIGHT (#50)	1
9	10-32070	FLOOR CORNER PANEL, RIGHT (#65)	1
10	10-32046	3/4" X 6 X 58-13/16" L, POLY FLOOR BOARD (MODIFIED RIGHT) (#25)	1
10	10-31991	3/4" X 6 X 75-1/4" L, POLY FLOOR BOARD (MODIFIED RIGHT) (#50)	1
10	10-32067	3/4" X 6 X 97-7/8" L, POLY FLOOR BOARD (MODIFIED RIGHT) (#65)	1

ASM: WEB CHAIN AND GEARS:

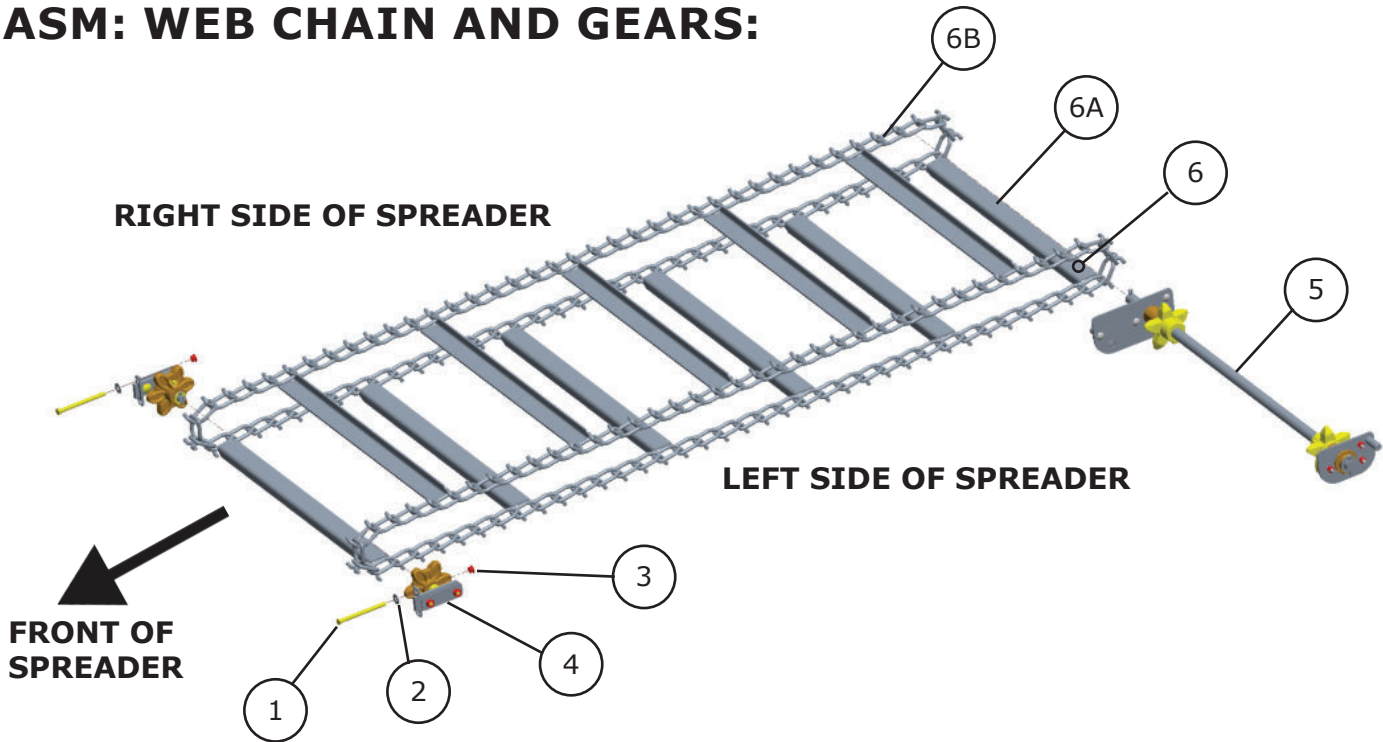

ITEM	PART #	DESCRIPTION	QTY
1	10-20428	3/8 X 5" FULL THREAD HEX BOLT: GR5	2
2	10-20429	3/8 FLAT WASHER	2
3	10-20430	3/8 SERRATED FLANGE NUT	2
4	10-90463	ASM: IDLER WEB	1
5	10-90485	ASM: REAR WEB CHAIN SHAFT AND SPROCKET (#25)	1
5	10-90467	ASM: REAR WEB CHAIN SHAFT AND SPROCKET (#50/#65)	1
6	10-90489	ASM: WEB CHAIN (#25)	2
6	10-90474	ASM: WEB CHAIN (#50)	2
6	10-90496	ASM: WEB CHAIN (#65)	2
6A	10-40588	WLDMT: WEB SLAT (#25)	9
6A		WLDMT: WEB SLAT (#25) (STAINLESS STEEL)	9
6B	10-40566	WLDMT: WEB SLAT (#50/#65)	11
6B		WLDMT: WEB SLAT (#50/#65) (STAINLESS STEEL)	11
6B	10-31943	3/8" TEE ROD WEB LINK (25/50/65)	13
6B		3/8" TEE ROD WEB LINK (25/50/65) (STAINLESS STEEL)	13

SPREADER SIZE	10-40588 QTY	10-40566 QTY	10-31943 QTY
25 cu/ft	9	N/A	96
50 cu/ft	N/A	11	122
65 cu/ft	N/A	13	156

ASM: FRONT WEB CHAIN GEAR: RIGHT

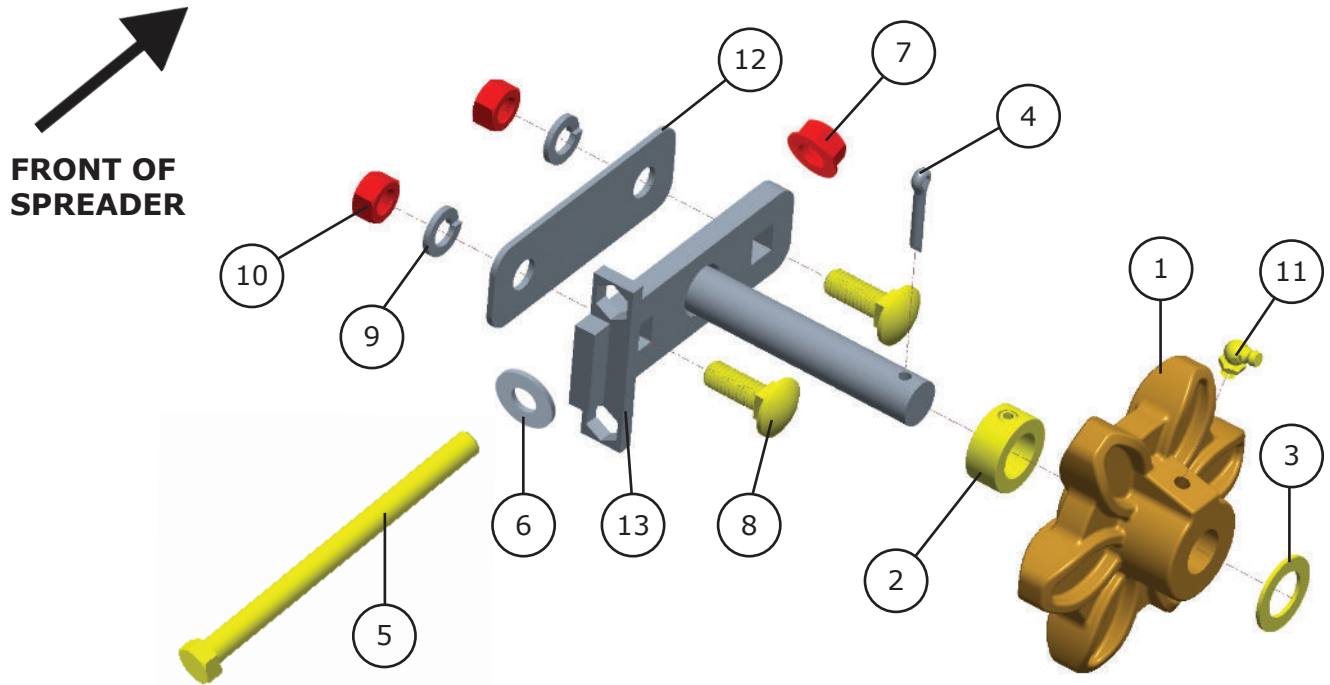

ITEM	PART #	DESCRIPTION	QTY
1	10-10996	6T WEB IDLER SPROCKET, 3/4" BORE	1
2	10-20425	3/4" SHAFT COLLAR	1
3	10-20426	3/4" MACHINE WASHER	1
4	10-20427	3/16 X 1" COTTER PIN	1
5	10-20428	3/8 X 5" FULL THREAD HEX BOLT: GR5	1
6	10-20429	3/8 FLAT WASHER	1
7	10-20430	3/8 SERRATED FLANGE NUT	1
8	10-20431	7/16 X 1-1/4" CARRIAGE BOLT	2
9	10-20432	7/16" LOCK WASHER	2
10	10-20433	7/16" HEX NUT	2
11	10-20448	1/4-28 65 DEG GREASE FITTING	1
12	10-31921	WEB IDLER PLATE	1
13	10-40558	WEB IDLER BRACKET	1
14	LSPWIB-C	WEB IDLER ASSEMBLY (#1-4,11,13) ASSEMBLY DOES NOT INCLUDE ITEMS 5 THROUGH 9 AND 12	1

ASM: FRONT WEB CHAIN GEAR: LEFT

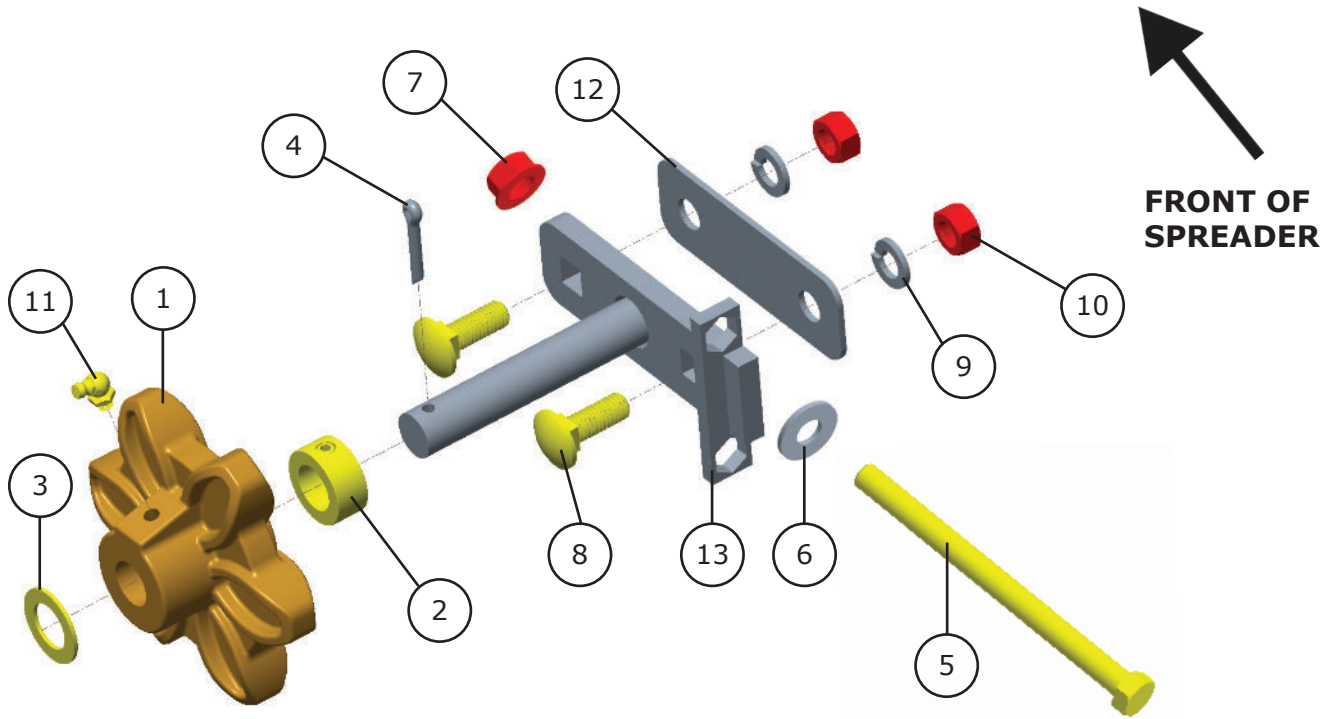

ITEM	PART #	DESCRIPTION	QTY
1	10-10996	6T WEB IDLER SPROCKET, 3/4" BORE	1
2	10-20425	3/4" SHAFT COLLAR	1
3	10-20426	3/4" MACHINE WASHER	1
4	10-20427	3/16 X 1" COTTER PIN	1
5	10-20428	3/8 X 5" FULL THREAD HEX BOLT: GR5	1
6	10-20429	3/8 FLAT WASHER	1
7	10-20430	3/8 SERRATED FLANGE NUT	1
8	10-20431	7/16 X 1-1/4" CARRIAGE BOLT	2
9	10-20432	7/16" LOCK WASHER	2
10	10-20433	7/16" HEX NUT	2
11	10-20448	1/4-28 65 DEG GREASE FITTING	1
12	10-31921	WEB IDLER PLATE	1
13	10-40558	WEB IDLER BRACKET	1
14	LSPWIB-C	WEB IDLER ASSEMBLY (#1-4,11,13) ASSEMBLY DOES NOT INCLUDE ITEMS 5 THROUGH 9 AND 12	1

ASM: REAR WEB CHAIN SHAFT AND GEAR:

RIGHT SIDE OF SPREADER

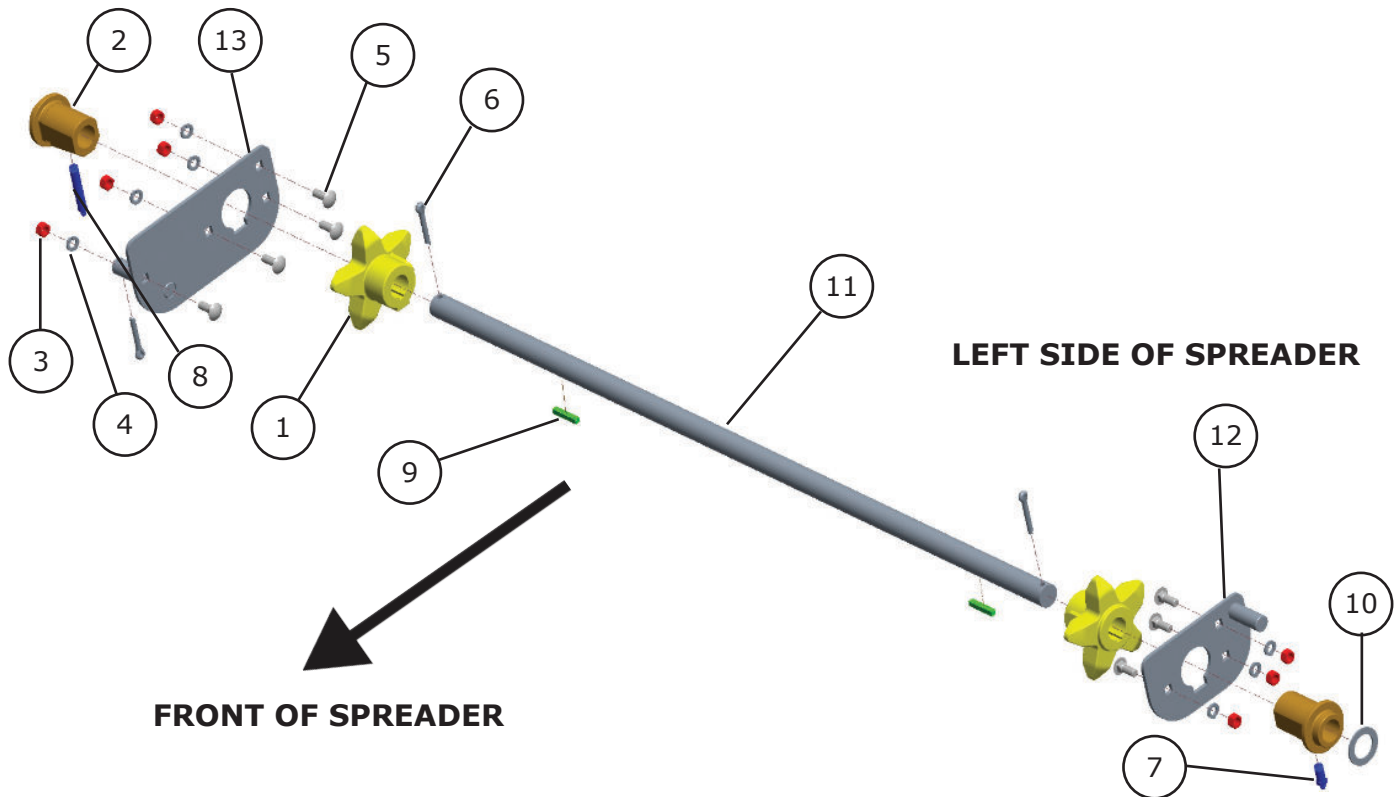

ITEM	PART #	DESCRIPTION	QTY
1	10-11006	WEB DRIVE SPROCKET, 1-1/16"	2
2	10-11007	1-1/16" WEB DRIVE BEARING	2
3	10-20130	3/8" HEX NUT	7
4	10-20133	3/8" LOCK WASHER	7
5	10-20379	3/8 X 1" CARRIAGE BOLT	7
6	10-20445	1/4 X 1-1/2" COTTER PIN	3
7	10-20446	1/8 NPT, X 1-1/4" GREASE FITTING	1
8	10-20447	1/8 NPT, X 2-5/8" GREASE FITTING	1
9	10-20449	KEY STOCK 1/4 X 1/4 X 1-1/2" LG	2
10	10-20452	1-1/8" MACHINE WASHER	1
11	10-32039	WEB DRIVE SHAFT (#25)	1
11	10-31945	WEB DRIVE SHAFT (#50/#65)	1
12	10-40568	WLDMT: LEFT WEB BEARING PLATE	1
13	10-40571	WLDMT: RIGHT WEB BEARING PLATE	1

ASM: CHAIN LIFT ARM:

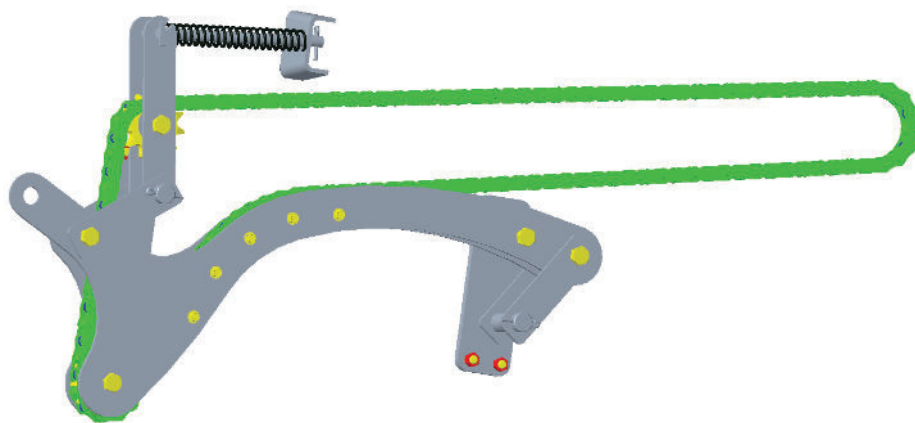
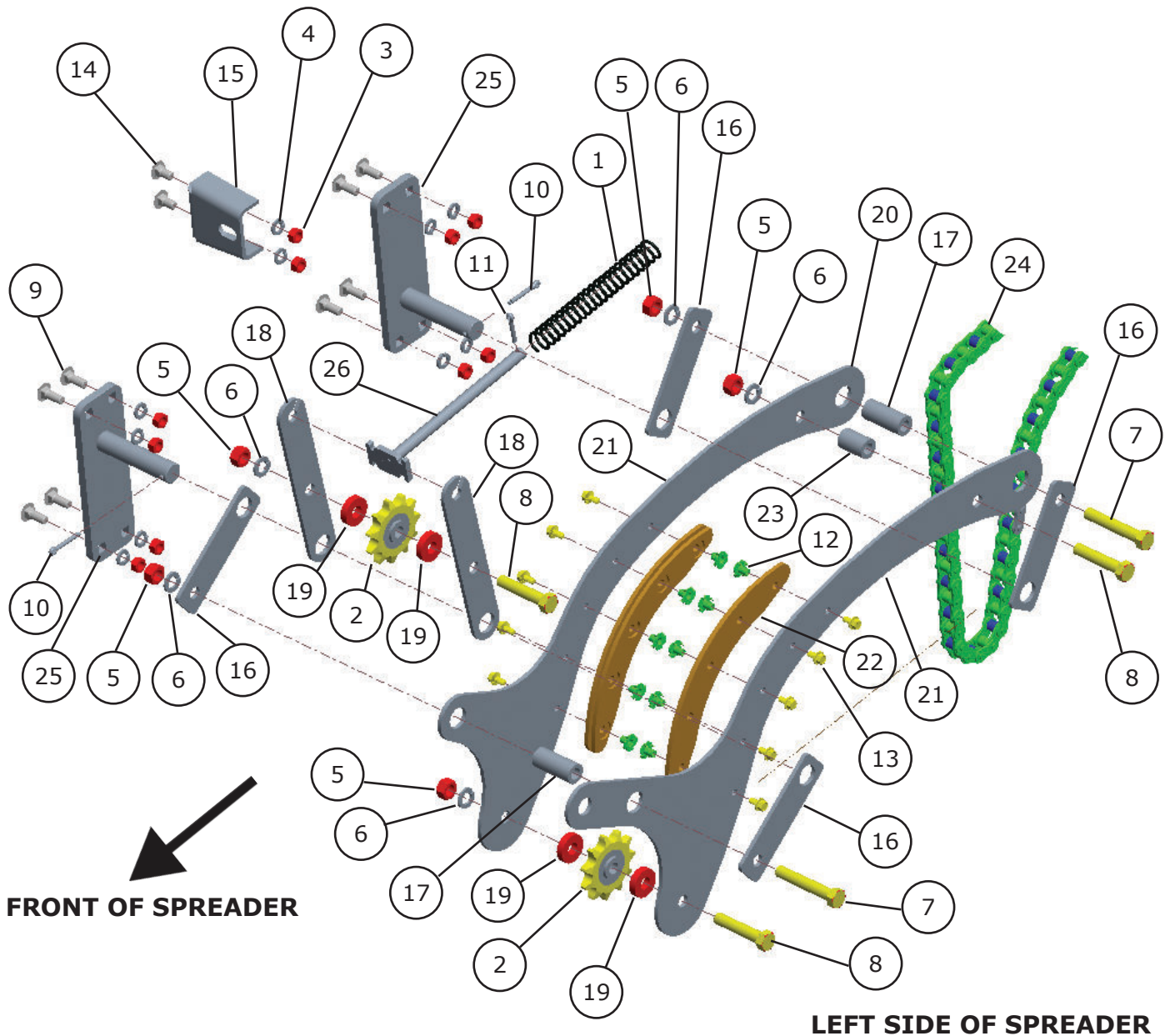

* ASSEMBLED UNIT SHOWN FOR CLARITY

ASM: CHAIN LIFT ARM (CONT'D):

ITEM	PART #	DESCRIPTION	QTY
1	10-10950	25/50/65 CHAIN ARM SPRING	1
2	10-11001	#60 X 11 IDLER SPROCKET	2
3	10-20130	3/8" HEX NUT	10
4	10-20133	3/8" LOCK WASHER	10
5	10-20138	1/2" HEX NUT	5
6	10-20139	1/2" LOCK WASHER	5
7	10-20168	1/2 X 3" HEX BOLT	2
8	10-20185	1/2 X 2-1/2" HEX BOLT	3
9	10-20379	3/8 X 1" CARRIAGE BOLT	8
10	10-20424	3/16 X 1-1/4" COTTER PIN	2
11	10-20427	3/16 X 1" COTTER PIN	1
12	10-20473	1/4" TEE NUT	10
13	10-20474	1/4 X 1/2" SERRATED FLANGE BOLT	10
14	10-20475	3/8 X 3/4" CARRIAGE BOLT	2
15	10-31974	ROD BRACKET	1
16	10-31975	LIFT ARM	4
17	10-31976	STEEL BUSHING 7/8 X 1/2 X 2"	2
18	10-31979	IDLER ARM	2
19	10-31980	SPACING WASHER	4
20	10-31983	CHAIN LIFTING ARM	1
21	10-31984	CHAIN LIFTING ARM W/ROD HOLE	1
22	10-31985	CHAIN SLIDE	2
23	10-31986	STEEL BUSHING 7/8 X 1/2 X 1-5/16"	1
24	10-40591	ASM: #25 MAIN DRIVE CHAIN	1
24	10-40555	ASM: #50 MAIN DRIVE CHAIN	1
24	10-40594	ASM: #65 MAIN DRIVE CHAIN	1
25	10-40575	WLDMT: MOUNTING BRACKET	2
26	10-40576	WLDMT: SPRING HOLDER	1

ASM: MAIN DRIVE CHAIN:

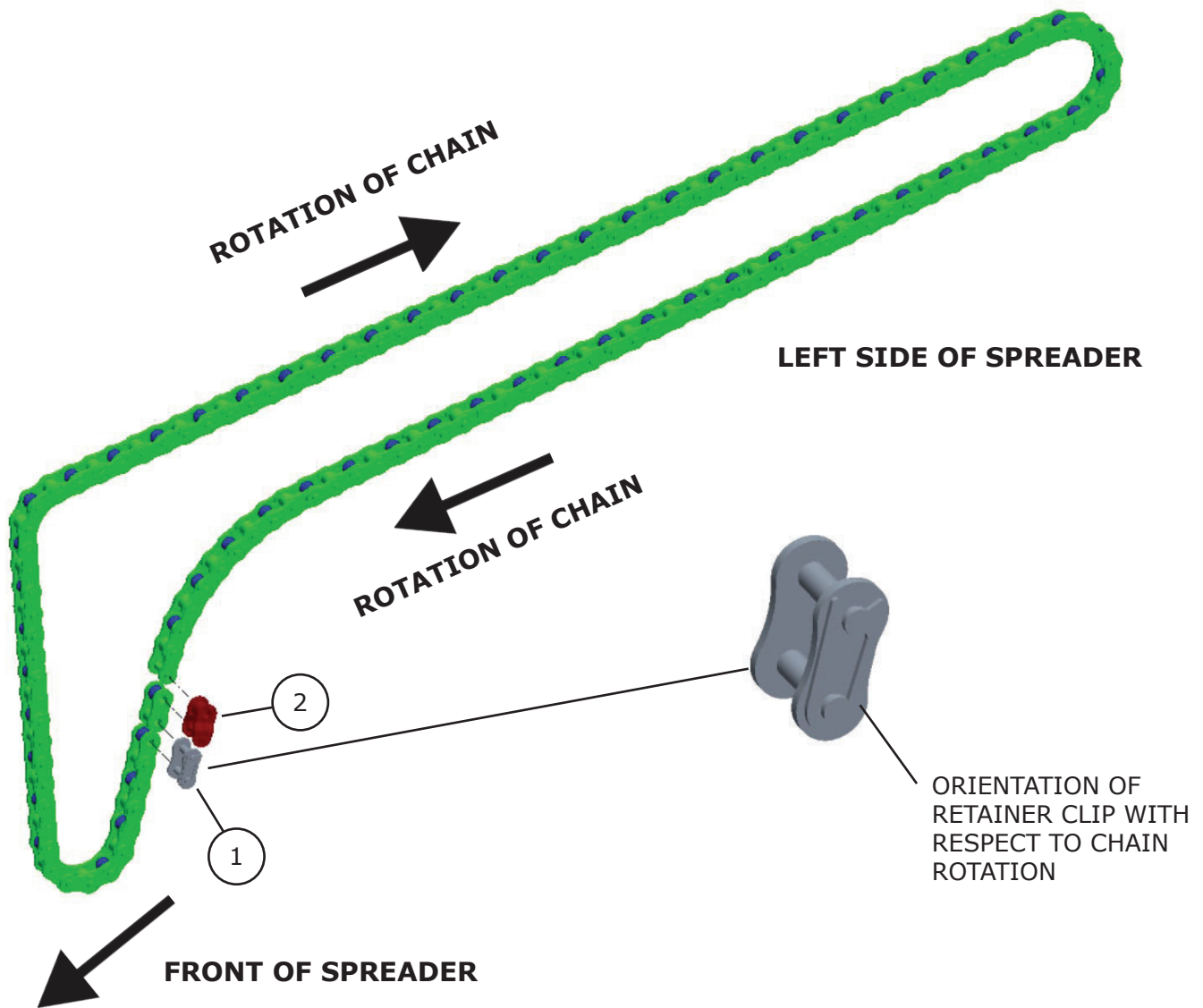

ITEM	PART #	DESCRIPTION
1	10-11015	#60 CONNECTING LINK (#25/50/65)
2	10-11021	#60 OFFSET/HALF LINK (#50/65)

SPREADER SIZE	LINK QTY	CONNECTING LINK QTY	OFFSET/HALF LINK QTY
25 cu/ft	51	1	N/A
50 cu/ft	63	1	1
65 cu/ft	72	1	1

ASM: BEATER:

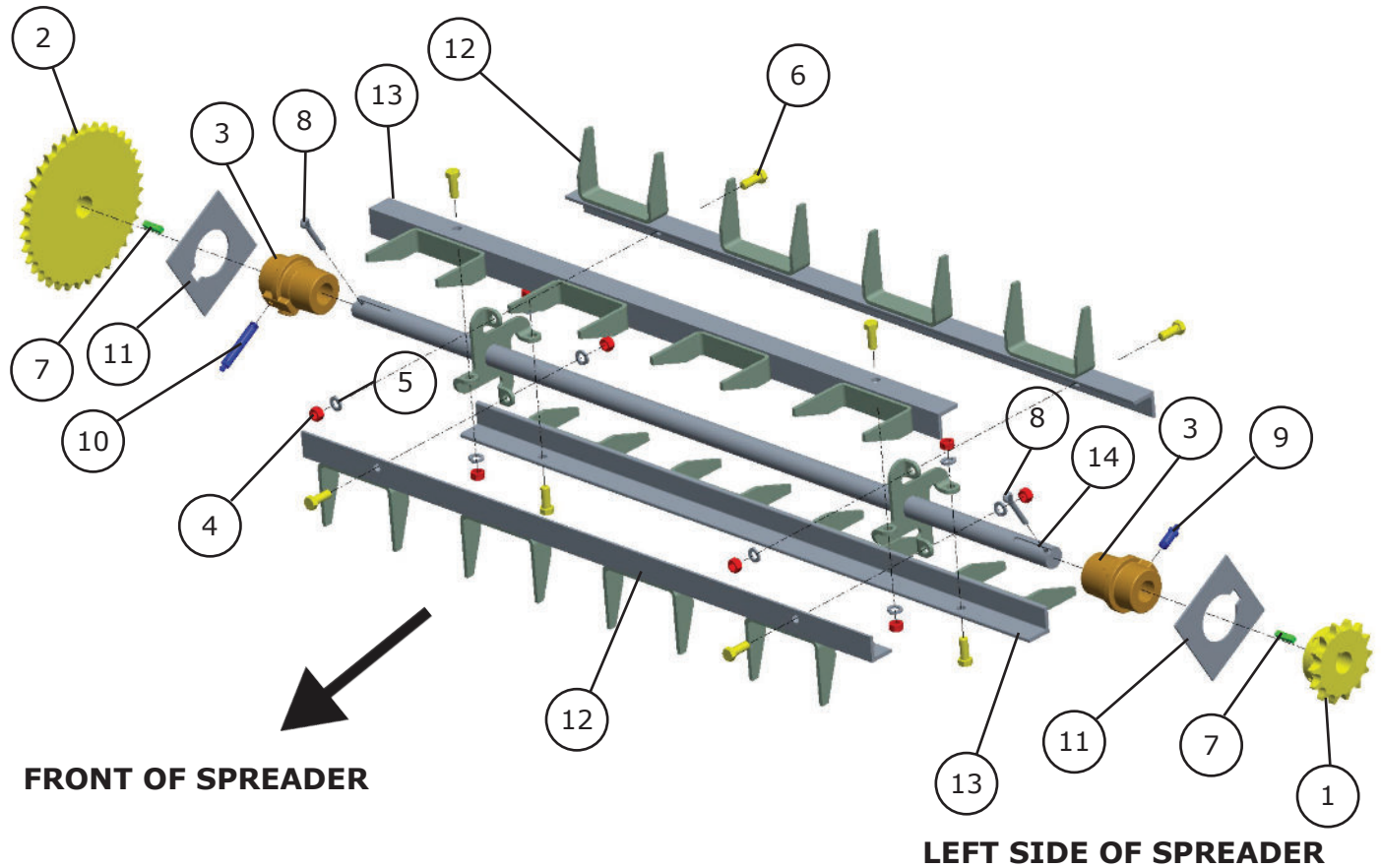

ITEM	PART #	DESCRIPTION	QTY
1	10-11002	#60 14 TOOTH X 1" SPROCKET	1
2	10-11003	#50 36 TOOTH X SPROCKET	1
3	10-11004	273 BEARING, 1" BORE	2
4	10-20130	3/8-16 HEX NUT	8
5	10-20133	3/8" LOCK WASHER	8
6	10-20279	3/8-16 X 1" HEX BOLT	8
7	10-20437	KEY STOCK: 1/4" X 1/4" X 1" LG	2
8	10-20445	1/4" X 1-1/2" COTTER PIN	2
9	10-20446	1/8 NPT X 1-1/4" GREASE FITTING	1
10	10-20447	1/8 NPT X 2-5/8" GREASE FITTING	1
11	10-31939	BEARING PLATE: TOP BEATER	2
12	10-40581	WLDMT: 27" BEATER BAR (#25)	4
12	10-40551	WLDMT: 34" BEATER BAR, RIGHT SIDE (#50/#65)	2
13	10-40552	WLDMT: 34" BEATER BAR, LEFT SIDE (#50/#65)	2
14	10-40587	WLDMT: BEATER SHAFT WITH HEADS (#25)	1
14	10-40564	WLDMT: BEATER SHAFT WITH HEADS (#50/#65)	1

ASM: WEB DRIVE:

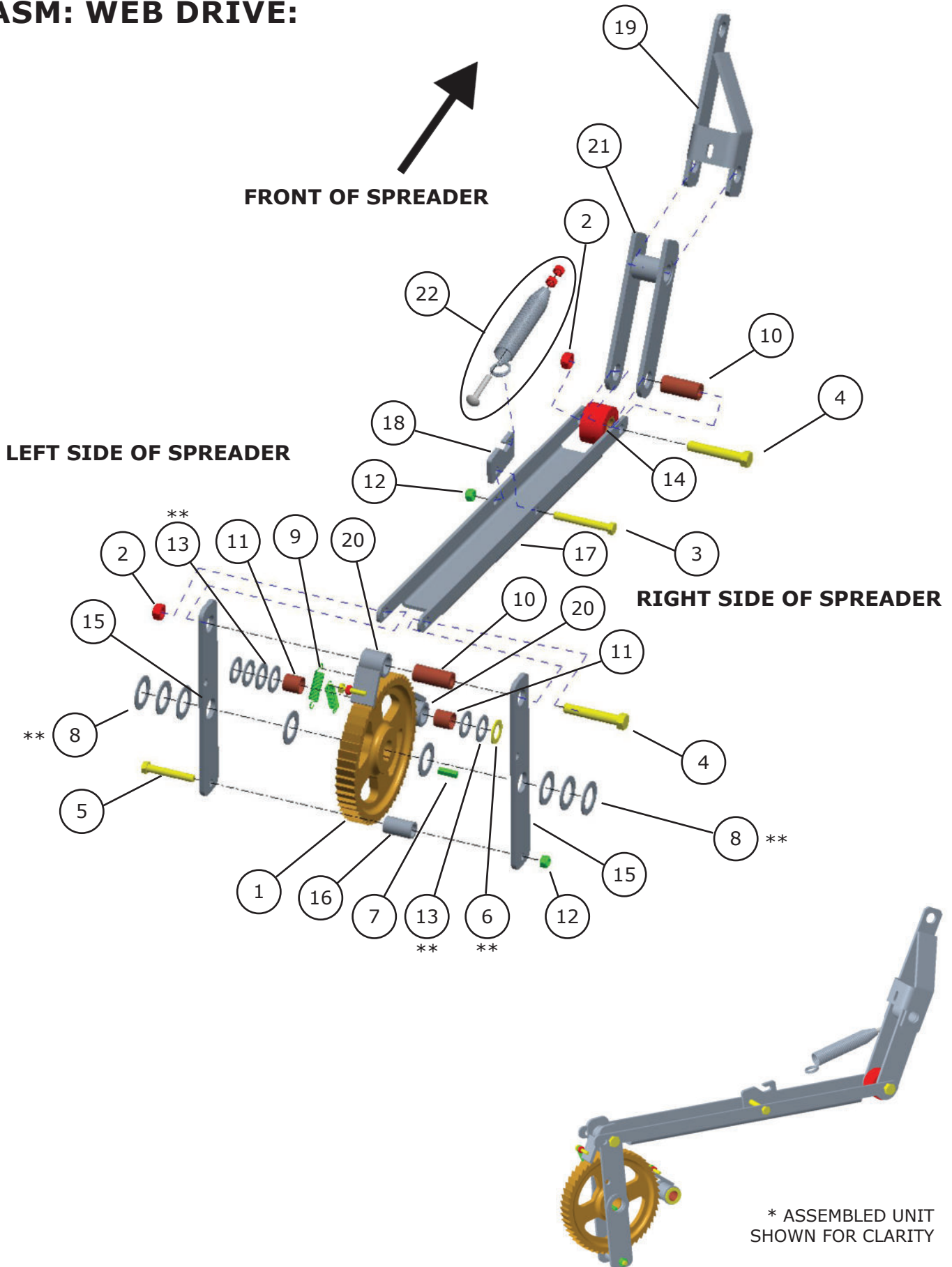

** MACHINE WASHER QUANTITY MAY VARY DUE TO TOLERANCE STACK-UP ON THE SPREADER COMPONENTS.

ASM: WEB DRIVE (CONT'D):

ITEM	PART #	DESCRIPTION	QTY
1	10-11008	SMALL WEB RATCHET GEAR	1
2	10-20050	1/2-13 LOCK NUT	2
3	10-20065	3/8-16 X 3" HEX HEAD BOLT	1
4	10-20168	1/2-13 X 3" HEX HEAD BOLT	2
5	10-20180	3/8-16 X 2-1/2" HEX HEAD BOLT	1
6	10-20426	3/4" MACHINE WASHER	** 1
7	10-20437	KEY STOCK 1/4 X 1/4 X 1" LG	1
8	10-20452	1-1/8" MACHINE WASHER	** 8
9	10-20455	WEB PAWL SPRING	2
10	10-20456	1/2 X 7/8 X 2" BRONZE BUSHING	2
11	10-20457	3/4 X 7/8 X 7/8" BRONZE BUSHING	2
12	10-20459	3/8-16 LOCK NUT	2
13	10-20460	7/8" MACHINE WASHER	** 6
14	10-20461	SMALL ROLLER	1
15	10-31951	WEB PAWL ARM	2
16	10-31954	3/8" I.D. X 1-1/2" LONG SPACER	1
17	10-32040	WEB PUSH ARM (#25)	1
17	10-31959	WEB PUSH ARM (#50)	1
17	10-32071	WEB PUSH ARM (#65)	1
18	10-31960	SPRING BRACKET	1
19	10-31961	YOKE ARM	1
20	10-40570	WEB DRIVE PAWL	2
21	10-40572	WLDMT: WEB ROLLER ARM	1
22	10-90615	ASM: WEB ARM EXTENSION SPRING	1

** MACHINE WASHER QUANTITY MAY VARY DUE TO TOLERANCE STACK-UP ON THE SPREADER COMPONENTS.

ASM: WHEEL AND AXLE: LEFT:

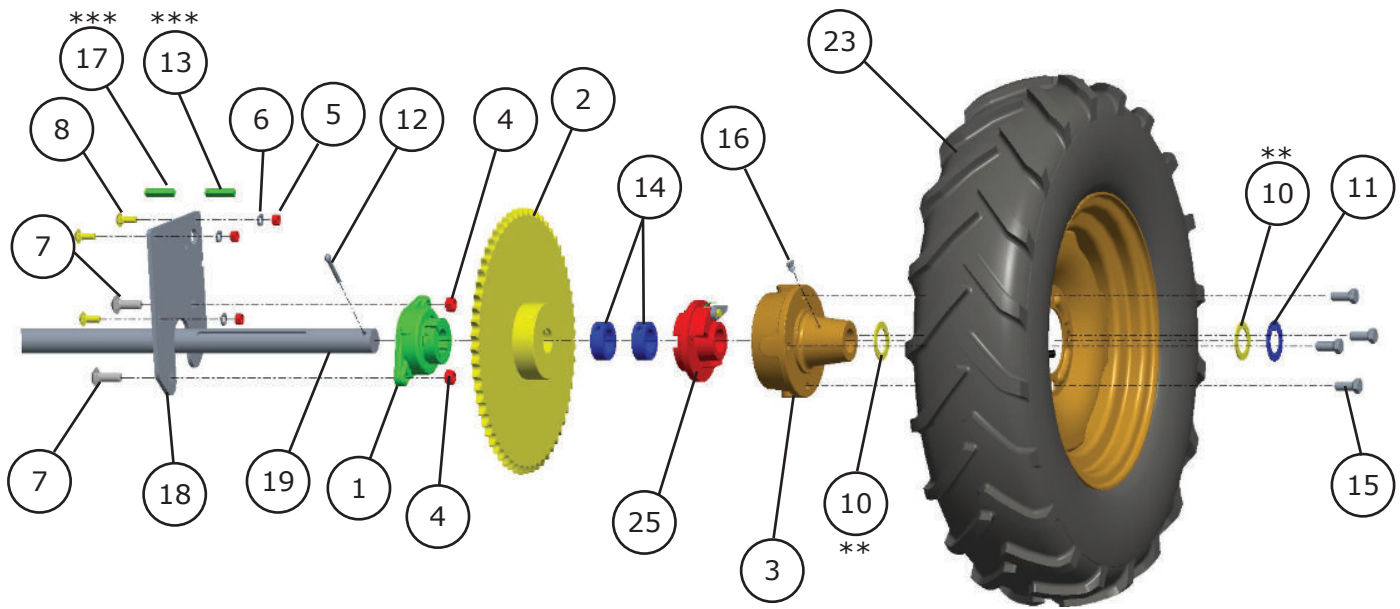

ASM: WHEEL AND AXLE: RIGHT:

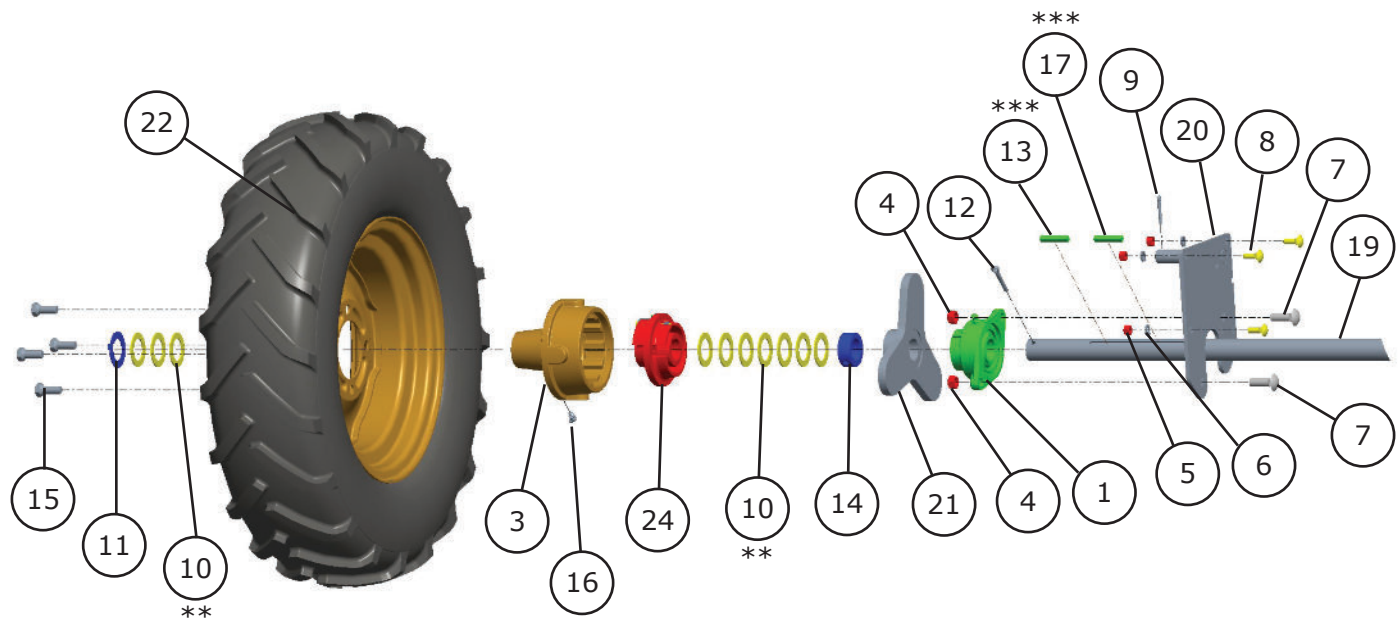

** MACHINE WASHER QUANTITY MAY VARY DUE TO TOLERANCE STACK-UP ON THE SPREADER COMPONENTS.

*** 10-20467: 5/16 X 5/16 X 1-3/4" KEY STOCK IS USED UNDER 10-90470: ASM: HUB BACKER, RIGHT AND 10-90471: ASM: HUB BACKER, LEFT (#65 MODELS ONLY).

*** 10-20587: 5/16 X 5/16 X 1-1/2" KEY STOCK IS USED UNDER 10-10998: AXLE SPROCKET AND 10-40574: WLDMT: WEB DRIVE CAM STAR (#65 MODELS ONLY).

*** 10-20463: 5/16 X 5/16 X 3-5/8" KEY STOCK IS USED BOTH ON SIDES OF THE UNIT IN PLACE OF 10-20467 AND 10-20587 (#25/50 MODELS ONLY).

ASM: WHEEL AND AXLE (CONT'D):

ITEM	PART #	DESCRIPTION	QTY
1	10-10997	AXLE BEARING	2
2	10-10998	AXLE SPROCKET	1
3	10-10999	4 ON 5 RATCHETING HUB	2
4	10-20050	1/2-13 LOCK NUT	4
5	10-20130	3/8-16 HEX NUT	6
6	10-20133	3/8" LOCK WASHER	6
7	10-20188	1/2-13 X 1-1/2" CARRIAGE BOLT	4
8	10-20379	3/8-16 X 1" CARRIAGE BOLT	6
9	10-20424	3/16 X 1-1/4" COTTER PIN	1
10	10-20464	1-3/8" MACHINE WASHER	** 4
11	10-20465	SHAFT/COTTER PIN WASHER	2
12	10-20466	1/4" X 1-3/4" COTTER PIN	2
13	10-20467	5/16" X 5/16" X 1-3/4" KEY STOCK (#65 ONLY) ***	2
14	10-20470	1-3/8" SHAFT COLLAR (#65 ONLY)	3
15	10-20480	1/2 WHEEL BOLT	8
16	10-20548	1/4-28 X 45 DEGREE ELBOW GREASE FITTING	2
17	10-20587	5/16" X 5/16" X 1-1/2" KEY STOCK (#65 ONLY) ***	2
17	10-20463	5/16" X 5/16" X 3-5/8" KEY STOCK (#25/50 ONLY) ***	2
18	10-31964	LEFT AXLE BEARING PLATE	2
19	10-32041	AXLE (#25)	1
19	10-31967	AXLE (#50)	1
19	10-32073	AXLE (#65)	1
20	10-40573	WLDMT: RIGHT AXLE BEARING PLATE	1
21	10-40574	WLDMT: WEB DRIVE CAM STAR	1
22	10-60079	RIGHT WHEEL ASM: 25X5.00-15 (#25/#50)	1
22	10-60086	RIGHT WHEEL ASM: 7.6-15 (#65)	1
23	10-60080	LEFT WHEEL ASM: 25X5.00-15 (#25/#50)	1
23	10-60087	LEFT WHEEL ASM: 7.6-15 (#65)	1
24	10-90470	ASM: HUB BACKER, RIGHT	1
25	10-90471	ASM: HUB BACKER, LEFT	1

ASM: HUB BACKER, RIGHT:

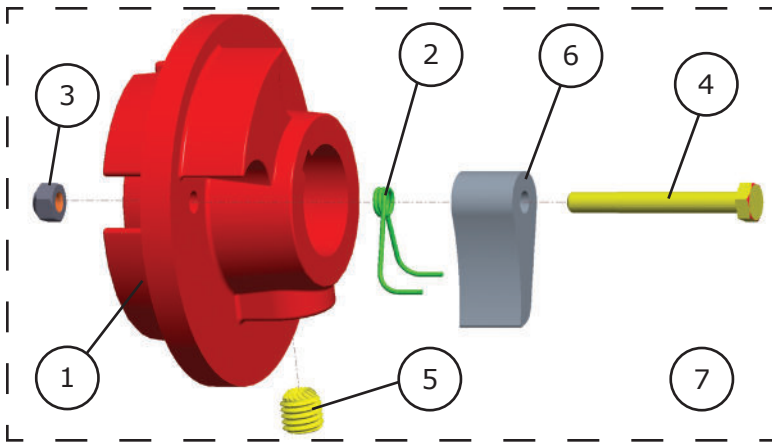

ITEM	PART #	DESCRIPTION	QTY
1	10-11000	HUB BACKER	1
2	10-11023	WHEEL PAWL SPRING	1
3	10-20414	1/4-20 LOCK NUT	1
4	10-20468	1/4-20 X 2-1/4" HEX BOLT	1
5	10-20469	1/2" X 1/2" ALLEN HEAD SET SCREW	1
6	10-31972	WHEEL PAWL, RIGHT	1
7	CALL	ASM: HUB BACKER, RIGHT	1

ASM: HUB BACKER, LEFT:

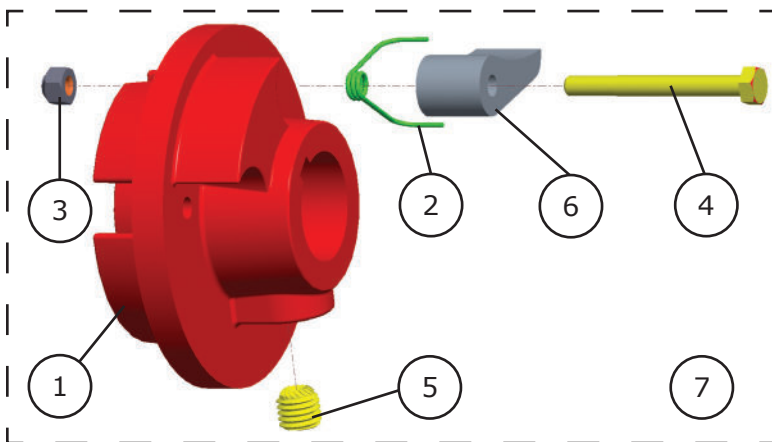

ITEM	PART #	DESCRIPTION	QTY
1	10-11000	HUB BACKER	1
2	10-11023	WHEEL PAWL SPRING	1
3	10-20414	1/4-20 LOCK NUT	1
4	10-20468	1/4-20 X 2-1/4" HEX BOLT	1
5	10-20469	1/2" X 1/2" ALLEN HEAD SET SCREW	1
6	10-31973	WHEEL PAWL, LEFT	1
7	CALL	ASM: HUB BACKER, LEFT	1

ASM: WIDE SPREAD:

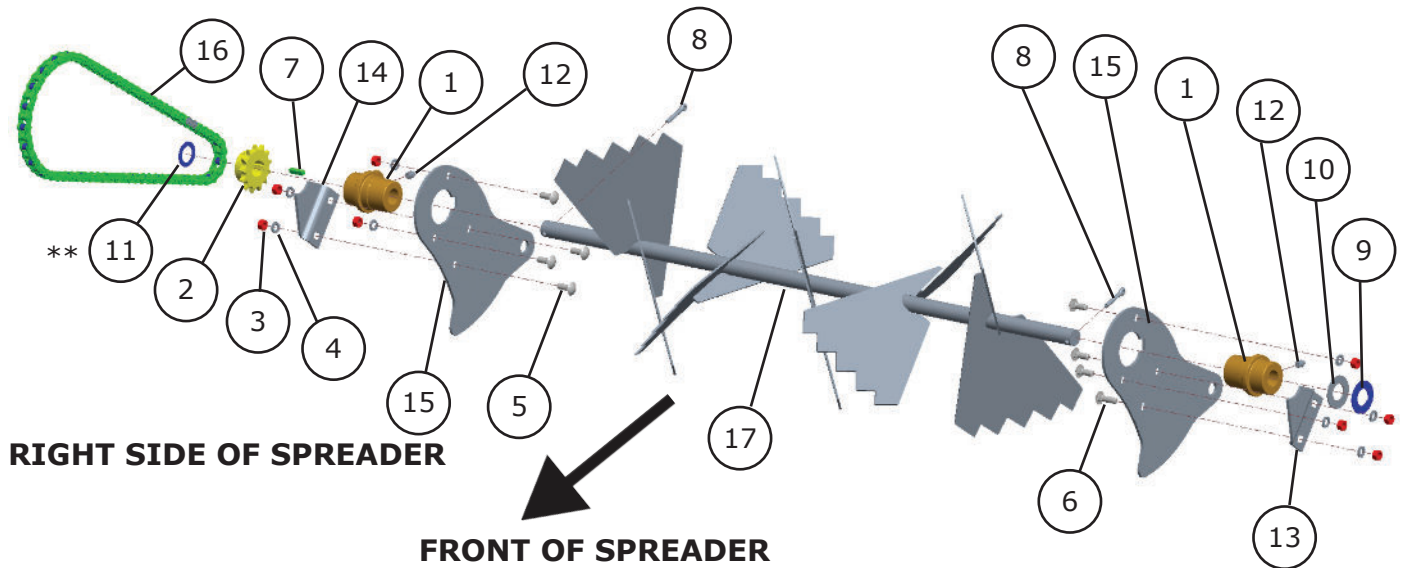

ITEM	PART #	DESCRIPTION	QTY
1	10-11004	273 BEARING, 1" BORE	2
2	10-11005	WIDESPREAD SPROCKET	1
3	10-20130	3/8-16 HEX NUT	8
4	10-20133	3/8" LOCK WASHER	8
5	10-20379	3/8-16 X 1" CARRIAGE BOLT	8
6	10-20398	3/8-16 X 1-1/4" CARRIAGE BOLT	1
7	10-20437	KEY STOCK: 1/4" X 1/4" X 1" LG	1
8	10-20438	1/4" X 1-1/4" COTTER PIN:	1
9	10-20439	1" COTTER PIN/SHAFT WASHER	1
10	10-20440	WASHER - WIDE RIM: 1.02" I.D., 2" O.D., ZINC	1
11	10-20441	MACHINE WASHER: 1" X 1-1/2" O.D.	** 1
12	10-20442	1/8 NPT STRAIGHT GREASE FITTING	2
13	10-31926	WIDESPREAD KEEPER PLATE, LEFT	1
14	10-31927	WIDESPREAD KEEPER PLATE, RIGHT	1
15	10-32010	WIDESPREAD BEARING PLATE	2
16	10-40549	#50 WIDESPREAD CHAIN (#25)	1
16	10-40553	#50 WIDESPREAD CHAIN (#50/#65)	1
17	10-40585	WLDMT: WIDESPREAD SHAFT W/ PADDLES (#25)	1
17	10-40560	WLDMT: WIDESPREAD SHAFT W/ PADDLES (#50/#65)	1

** MACHINE WASHER QUANTITY MAY VARY DUE TO TOLERANCE STACK-UP ON THE SPREADER COMPONENTS.

#50 WIDESPREAD CHAIN (#25/#50/#65):

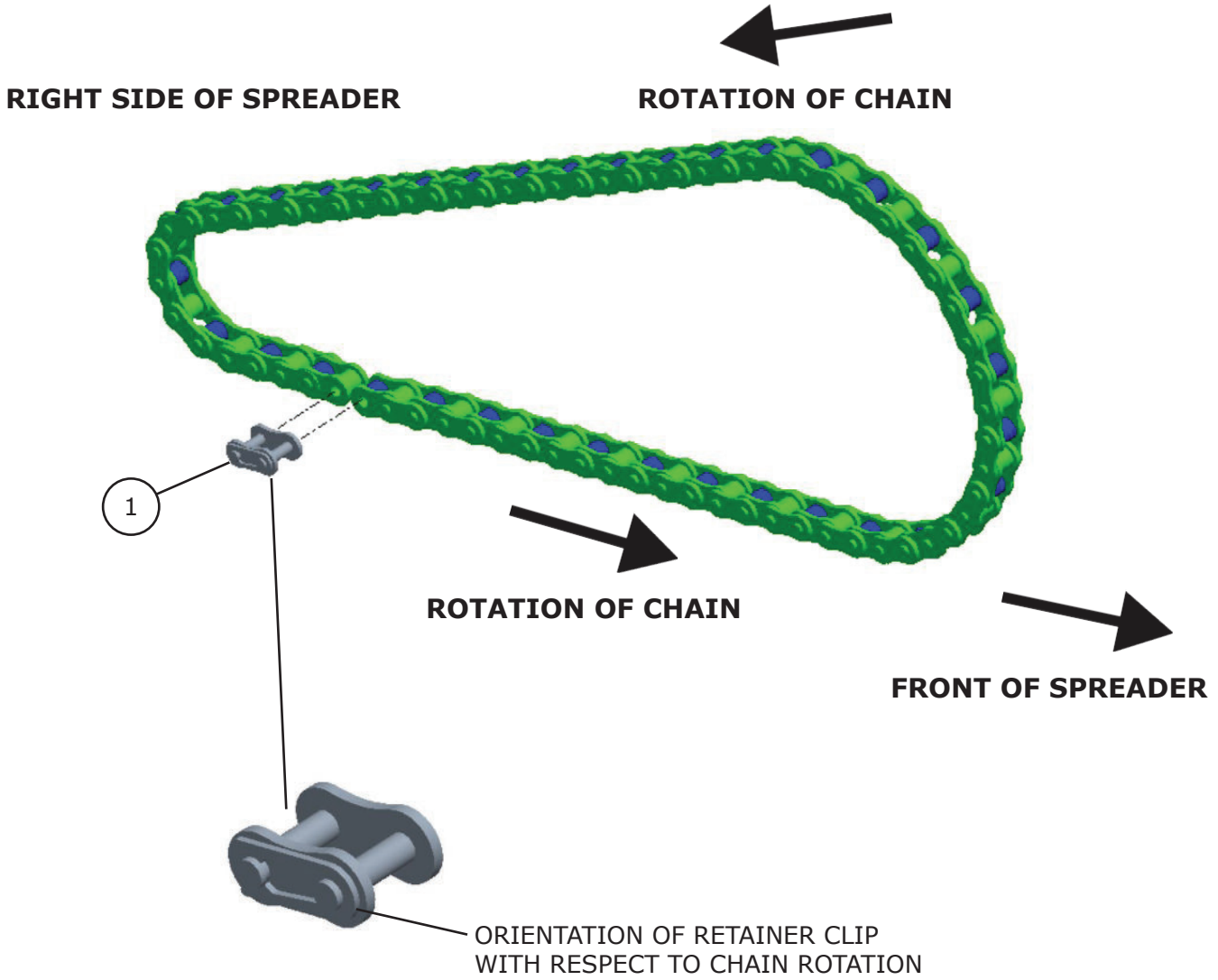

ITEM	PART #	DESCRIPTION
1	10-10946	#50 OFFSET/HALF CONNECTING LINK

SPREADER SIZE	LINK QTY	CONNECTING LINK QTY
25 cu/ft	34	1
50 cu/ft	35	1
65 cu/ft	35	1

OPTIONS:

ASM: END GATE:

NOTE: LOWER THE END GATE USING THE HANDLE TO AVOID DROPPING THE END GATE ONTO THE SIDE RAILS OF THE SPREADER

RIGHT SIDE OF SPREADER

LEFT SIDE OF SPREADER

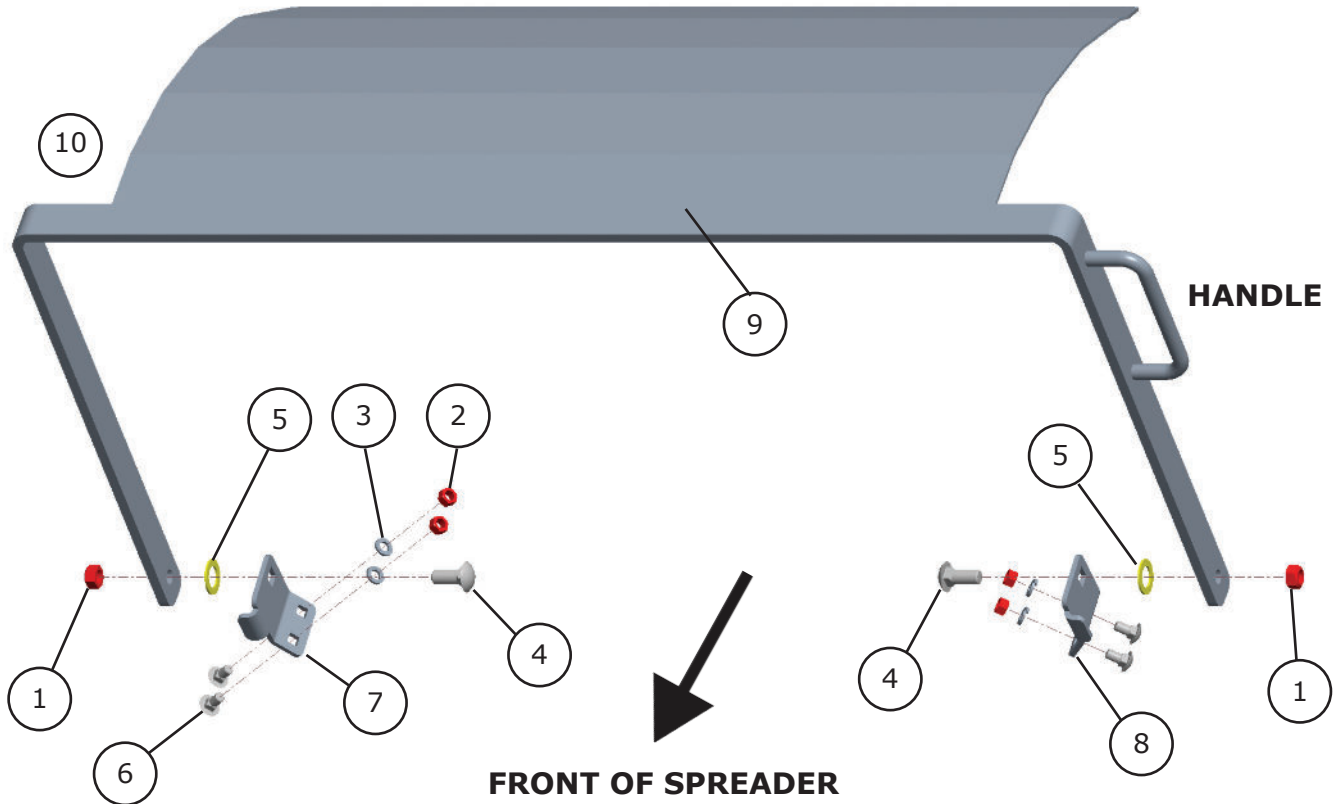

ITEM	PART #	DESCRIPTION	QTY
1	10-20050	1/2-13 LOCK NUT	2
2	10-20130	3/8" HEX NUT	4
3	10-20133	3/8" LOCK WASHER	4
4	10-20270	1/2 X 1-1/4" CARRIAGE BOLT	2
5	10-20426	3/4" MACHINE WASHER 1.25" OD	2
6	10-20475	3/8 X 3/4" CARRIAGE BOLT	4
7	10-31901	END GATE BRACKET, RIGHT	1
8	10-31902	END GATE BRACKET, LEFT	1
9	10-40580	WLDMT: END GATE PANEL (#25)	1
9	10-40550	WLDMT: END GATE PANEL (#50/#65)	1
10	10-90508	ASM: END GATE COMPLETE (#25)	1
10	10-90499	ASM: END GATE COMPLETE (#50/65)	1

END GATE INSTALLATION:

TOOLS NEEDED:

- GLOVES
- SAFETY GLASSES
- SAFETY SHOES
- PUNCH & HAMMER
- (2) 9/16" COMBINATION WRENCHES OR (2) 9/16" SOCKET SET

1. Remove the left chain guard using a 9/16" wrench (or socket set) before laying the End Gate on the spreader **(Figure 45.1)**.
1. Using a punch and hammer, remove the two square punch-outs on each side of the spreader by sliding the tip of screwdriver into the slits of the punch-outs and pry out the punch-outs. These punch-outs are located along the top edge of the box of the spreader. **(Figure 45.2)**.
2. Remove the plastic wrap covering the brackets and hardware on both ends of the support bar on the End Gate then remove the two bolts, nuts, and lockwashers from both brackets on the End Gate using a 9/16" wrench (or socket set).
3. Lay End Gate on spreader and line the holes in the brackets of the End Gate with the punched out holes on the spreader (this may require 2 people) **(Figure 45.2)**.
4. Insert the bolts from the top side and then install the lockwashers and nuts from underneath. Once you have all 4 bolts in place, tighten down the nuts using a 9/16" wrench (or socket set) **(Figure 45.2)**.
5. Once all 4 bolts are tightened securing the End Gate to the spreader, raise the End Gate and re-attach the left chain guard and secure with bolts, lockwashers and nuts using a 9/16" wrench (or socket set) **(Figure 45.3)**.

KEEP HANDS CLEAR FROM EXPOSED CHAIN AND MOVING PARTS

REMOVE LEFT CHAIN GUARD USING 9/16" WRENCH BEFORE LAYING END GATE ON SPREADER



Figure 45.1

NOTE:

REMOVE (2) PUNCH-OUTS WITH PUNCH AND HAMMER; INSERT THE BOLTS FROM THE TOP SIDE AND INSTALL THE LOCKWASHERS AND NUTS FROM UNDERNEATH; ONCE TIGHTENED RAISE THE END GATE TO RE-ATTACH LEFT CHAIN GUARD. **(FIGURE 45.2)**.

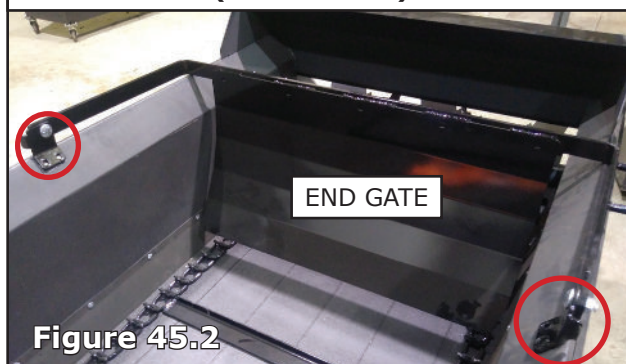

Figure 45.2

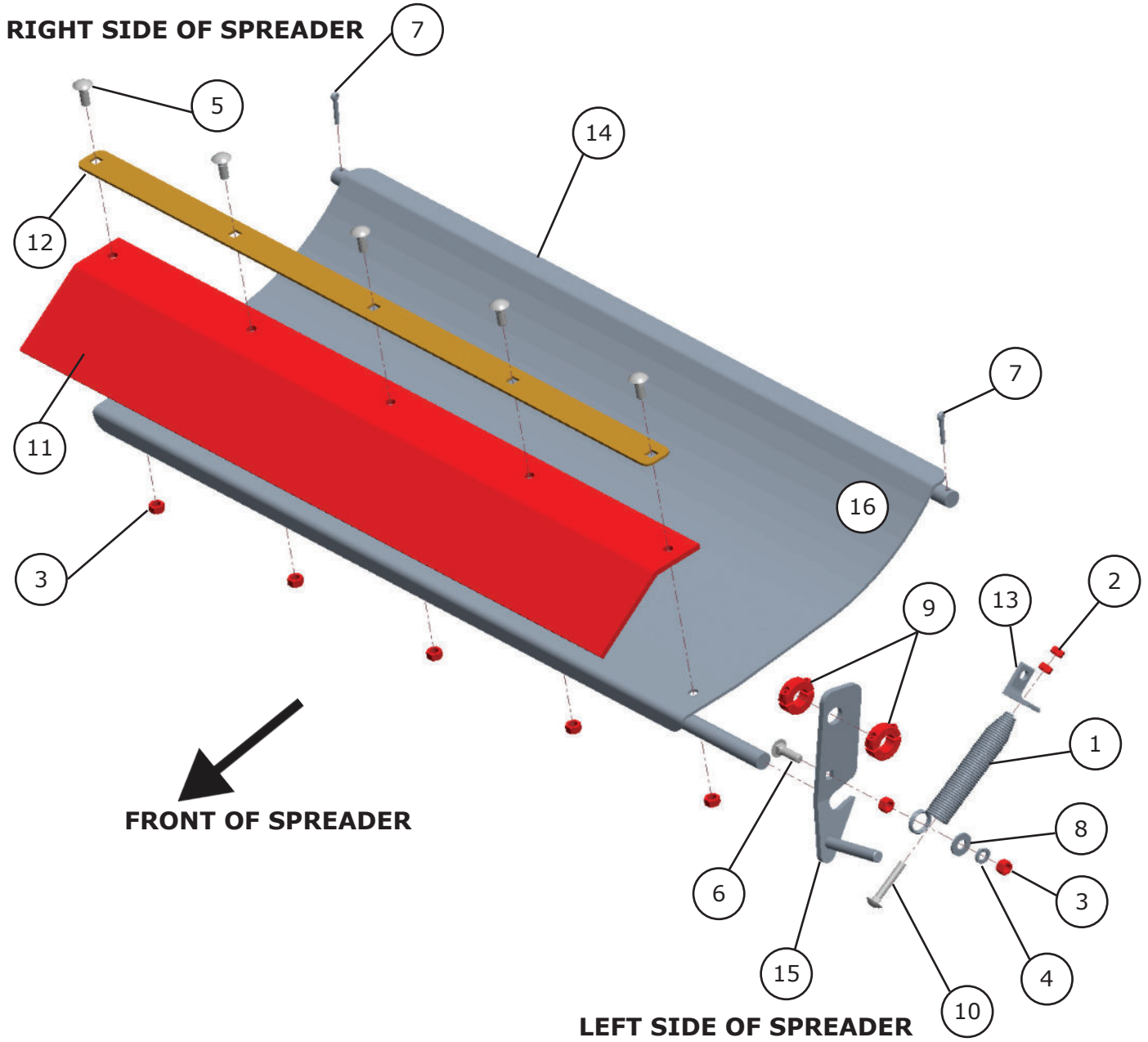

Figure 45.3

LOWER THE END GATE USING THE HANDLE TO AVOID DROPPING THE END GATE ONTO THE SIDE RAILS OF THE SPREADER

RE-ATTACH LEFT CHAIN GUARD TO MANURE SPREADER

ASM: LITTER/FINE PAN:



ASM: LITTER/FINE PAN (CONT'D):

ITEM	PART #	DESCRIPTION	QTY
1	10-10949	SPRING	1
2	10-20126	5/16" HEX NUT	2
3	10-20130	3/8" HEX NUT	7
4	10-20133	3/8" LOCK WASHER	1
5	10-20379	3/8 X 1" CARRIAGE BOLT	5
6	10-20398	3/8 X 1-1/4" CARRIAGE BOLT	1
7	10-20424	3/16 X 1-1/4" COTTER PIN	2
8	10-20429	3/8" FLAT WASHER	1
9	10-20453	SPLIT SHAFT COLLAR, ZINC	2
10	10-20481	5/16 X 2" CARRIAGE BOLT	1
11	10-32035	FRONT RUBBER (#25)	1
11	10-31935	FRONT RUBBER (#50/#65)	1
12	10-32036	RUBBER HOLDER (#25)	1
12	10-31936	RUBBER HOLDER (#50/#65)	1
13	10-31950	SPRING ANGLE BRACKET	1
14	10-40586	WLDMT: LITTER/FINE PAN (#25)	1
14	10-40562	WLDMT: LITTER/FINE PAN (#50/#65)	1
15	10-40569	WLDMT: LITTER/FINE PAN LATCH	1
16	10-90483	ASM: LITTER/FINE PAN COMPLETE (#25)	1
16	10-90465	ASM: LITTER/FINE PAN COMPLETE (#50/65)	1

LITTER/FINE PAN INSTALLATION:

TOOLS NEEDED:

- GLOVES
 - SAFETY GLASSES
 - SAFETY SHOES
 - PLIERS
 - 9/16" WRENCH (OR SOCKET SET)
 - 3/16" ALLEN WRENCH
1. Remove both cotter pins using a pair of pliers from the safety bar at the rear of the spreader and remove the safety bar (**Figure 48.1 - 48.2**).
 2. Install the litter pan in place of the safety bar and secure with cotter pins removed in **Step 1 (Figure 48.3)**.
 3. Remove the bottom left rear bolt/lockwasher/nut from the spreader using a 9/16" wrench (or socket set). The lockwasher and nut will be reused but the bolt will be replaced with the longer bolt included with your litter pan (**Figure 48.4**).
 4. Install one of the locking collars on the protruding rod welded to the left web chain shaft mounting plate. Leave it loose until everything is installed to allow for final adjustments. (**Figure 48.5 - 49.1**).
 5. On the same rod, install the latch arm/spring assembly with latch arm handle rod facing outward away from the spreader. Then install the other lock collar onto the rod. (**Figure 49.2**).
 6. Install the longer 3/8-16 x 1-1/4" bolt into the spreader side plate where the bolt was removed earlier in **Step 3**. Slide "L" bracket attached to Latch arm/spring assembly onto the longer bolt. Replace the lockwasher and nut removed in **Step 3** and tighten using 9/16" wrench (or socket set) (**Figure 49.3 - 49.4**).
 7. Adjust so the latch has enough clearance to attach to the litter pan and tighten down the lock collars using a 3/16" Allen Wrench (**Figure 49.5**).
 8. To close Litter/Fine Pan, grab handle welded to Litter/Fine Pan and lift until handle locks into notch on Latch arm/spring assembly.

9. To release Litter/Fine Pan, pull Latch arm/spring assembly handle toward front of spreader and the Litter/Fine Pan will drop (**Figure 49.6 - 49.9**).

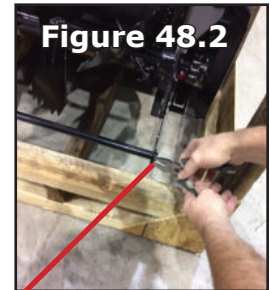
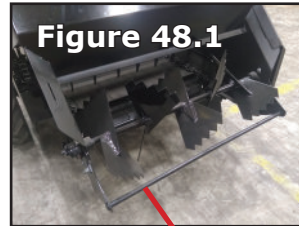

SAFETY BAR
REMOVE COTTER PIN
ON BOTH ENDS OF
SAFETY BAR

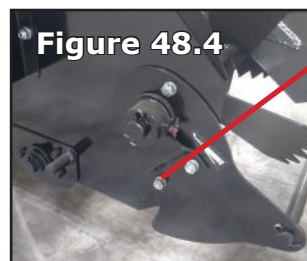

REMOVE THIS NUT,
LOCKWASHER
AND BOLT. THE
LOCKWASHER AND NUT
WILL BE USED LATER

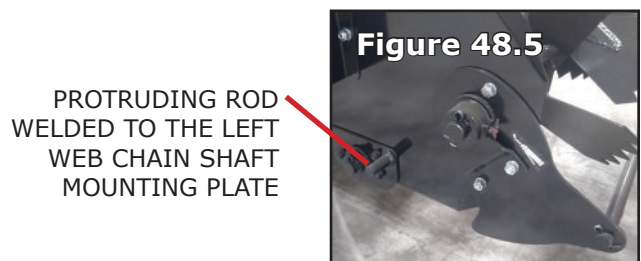

PROTRUDING ROD
WELDED TO THE LEFT
WEB CHAIN SHAFT
MOUNTING PLATE

BE CAREFUL NOT TO PINCH YOUR FINGERS!

LITTER/FINE PAN INSTALLATION (CONT'D):

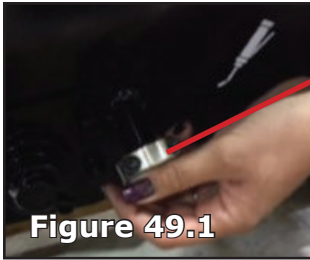

1ST LOCKING COLLAR MOUNTED ON ROD

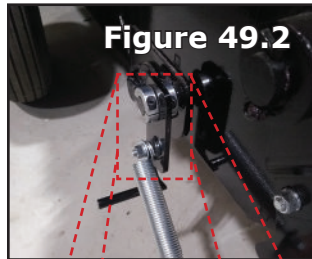

LATCH ARM/SPRING ASSEMBLY AND 2ND LOCKING COLLAR

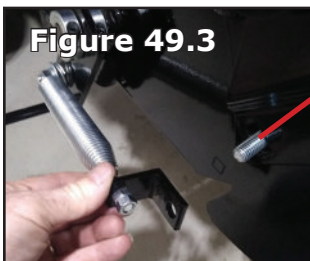

INSTALL 3/8-16 X 1-1/4" LONG BOLT FROM KIT



SLIDE "L" BRACKET ONTO BOLT ALONG WITH LOCKWASHER. THREAD NUT ONTO BOLT AND TIGHTEN.

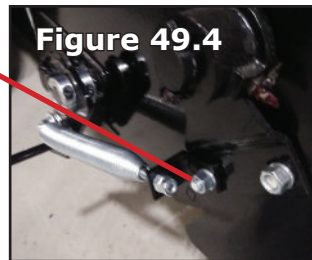

USE 3/16" ALLEN WRENCH TO TIGHTEN BOTH SCREWS ON BOTH LOCKING COLLARS.



BALL HITCH INSTALLATION:

TOOLS NEEDED:

- GLOVES
- SAFETY SHOES
- (2) 3/4" COMBINATION WRENCHES
- (2) 15/16" COMBINATION WRENCHES



1. Slide bolt (supplied with kit) through hole in top hitch bar then through back hole in the top of the hitch. Continue to slide bolt through hole in the bottom hitch bar. **(Figure 50.1 - 50.2).**
2. Slide washer (supplied in kit) onto bolt then thread nut (supplied in kit) onto bolt. Tighten with (2) 15/16" wrenches **(Figure 50.3).**
3. Tighten both nuts on the side of the hitch with (2) 3/4" wrenches **(Figure 50.3).**

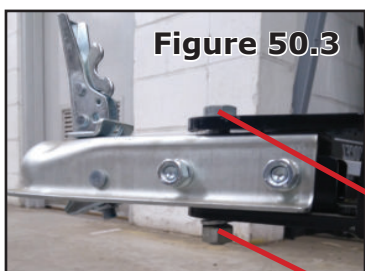

BOLT GOES THROUGH BACK HOLE IN HITCH

Figure 50.3

5/8-11 BOLT

5/8" WASHER AND NUT

If the Tongue top and bottom hitch bars are not parallel to each other, it may be hard to slide the ball hitch in between them.

1. If this happens, try using a hammer to gently tap the hitch into place. If it's too tight to tap the hitch into place, take a 5/8-11 bolt that is 4" long or longer (must be a full thread bolt: If a full thread bolt is not ready available, a 5/8-11 carriage bolt will work) and slide a 5/8" washer onto the bolt.
2. Run the bolt up through the bottom hitch bar but not through the top bar. Slide a second 5/8" washer onto the bolt then thread (2) 5/8-11 nuts onto the bolt then slide a third 5/8" washer onto the bolt. Push the bolt up through the hole of the top hitch bar as shown and tighten first nut against bottom hitch bar.
3. Start turning the 2nd 5/8-11 nut counter-clockwise (using a 15/16" wrench removing the nut from the bolt) until it's snug against the underside of the top hitch bar **(Figure 50.4).**
4. Continue turning the nut to wedge the 2 bars apart until the ball hitch can slide in between the 2 bars **(Figure 50.5).**
5. Remove the bolt, washers and nuts and assemble the ball hitch as described above (hardware to spread the hitch bars apart are not supplied with ball hitch kit).

ROTATE TOP NUT COUNTER-CLOCKWISE TO WEDGE TOP AND BOTTOM HITCH BARS APART UNTIL HITCH CAN SLIDE BETWEEN BARS. REMOVE BOLTS, WASHERS AND NUTS AND POSITION HITCH AS MENTIONED ABOVE.



Figure 50.4



Figure 50.5

CONTACT INFORMATION:

ABI Attachments, Inc
520 S. Byrkit Ave.
Mishawaka, IN 46544

CUSTOMER SUPPORT:

Phone: (877)788-7253
Hours: Monday - Friday | 9AM - 5PM EST
Email: support@abiattachments.com
Web: abisupport.com

For additional information on this equipment, or to order replacement parts, please contact our Customer Support Team at (877)788-7253 to speak with one of our representatives.

Additional support videos are available at the ABI Support Page under each tool.

Warranty and return policy information can also be found on the ABI Support Page under each tool. For additional questions regarding warranty or return policy, please contact our Customer Support Team at (877)788-7253 to speak with one of our representatives.



ABI[®]
ATTACHMENTS