

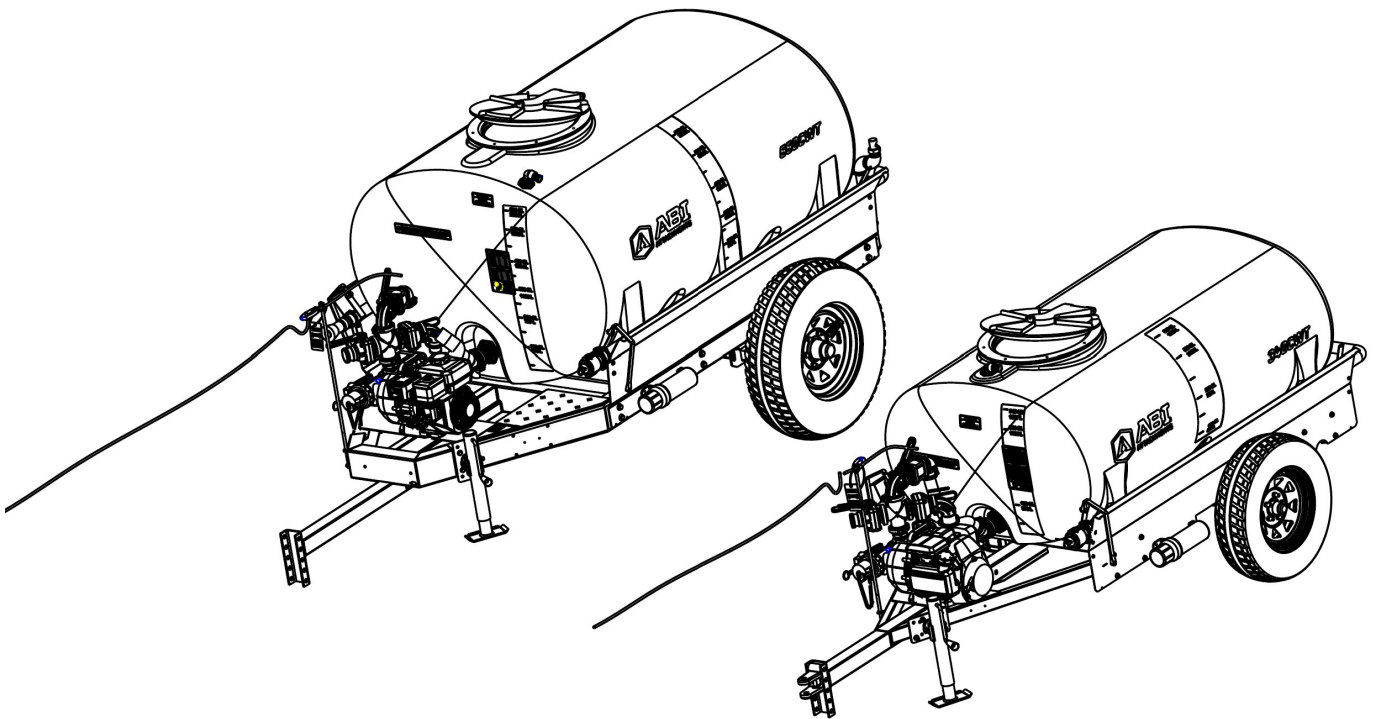

OWNERS MANUAL

Water Trailer

340/550 Gallon



This document covers several models. Features may vary by model. Not all features in this document are applicable to all models. The model depicted may differ from yours.

For Your Records

Located on the front left angled portion of the frame is an ID plate showing the serial number. Record your machine's information and serial number in the space provided below. ABI will use this information to give you prompt, efficient service when you order parts or need product support.

Model and Serial Number

| |
|--------------------------------|
| Model Number: _____ |
| Serial Number: _____ |
| Invoice Number: _____ |
| Purchaser's Name: _____ |

Contact Information

ABI Attachments, Inc
520 S. Byrkit Ave.
Mishawaka, IN 46544

Customer Support

Email: abicutomerservice@abiattachments.com
Phone: 877-788-7253
Website: abiattachments.com/support

Table of Contents

| | |
|------------------------------|----|
| Safety..... | 3 |
| SafetyLabels..... | 6 |
| Uncrating Instructions..... | 7 |
| Setup..... | 8 |
| Operation Guide..... | 10 |
| Specifications..... | 16 |
| Basic Operations..... | 17 |
| Maintenance..... | 18 |
| Replacement Parts..... | 19 |
| Trouble Shooting & FAQs..... | 20 |
| Options..... | 21 |

Safety



WARNING! The *SAFETY ALERT SYMBOL* indicates there is a potential hazard to personal safety involved and extra safety precaution must be taken. When you see this symbol, be alert and carefully read the message that follows it. In addition to design and configuration of equipment, hazard control, and accident prevention are dependent upon the awareness, concern, prudence, and proper training of personnel involved in the operation, transport, maintenance, and storage of equipment.



CALIFORNIA PROPOSITION 65

WARNING! Cancer and reproductive harm- www.P65Warnings.ca.gov

SAFETY AT ALL TIMES

Careful operation is your best assurance against an accident. All operators, no matter how much experience they may have, should carefully read this manual and other related manuals, or have the manuals read to them, before operating the tow vehicle and this implement.

- Thoroughly read and understand the “Safety Label” section. Read all instructions noted on them.
- Do not operate the equipment while under the influence of drugs or alcohol as they impair the ability to safely and properly operate the equipment.
- The operator should be familiar with all functions of the tow vehicle and attached implement and be able to handle emergencies quickly.
- Make sure all guards and shields appropriate for the operation are in place and secured before operating implement.
- Keep all bystanders away from equipment and work area.
- Start tow vehicle from the driver’s seat with hydraulic controls in neutral.
- Operate tow vehicle and controls from the driver’s seat only.
- Never dismount from a moving tow vehicle or leave tow vehicle unattended with engine running.
- Do not allow anyone to stand between tow vehicle and implement while backing up to implement.
- Keep hands, feet, and clothing away from power-driven parts.
- While transporting and operating equipment, watch out for objects overhead and along side such as fences, trees, buildings, wires, etc.
- Do not turn tow vehicle so tight as to cause hitched implement to ride up on the tow vehicle’s rear wheel.
- Store implement in an area where children normally do not play. When needed, secure attachment against falling with support blocks.

SAFETY PRECAUTIONS FOR CHILDREN

Tragedy can occur if the operator is not alert to the presence of children. Children generally are attracted to implements and their work.

- Never assume children will remain where you last saw them.
- Keep children out of the work area and under the watchful eye of a responsible adult.
- Be alert and shut the implement and tractor down if children enter the work area.
- Never carry children on the tractor or implement. There is not a safe place for them to ride. They may fall off and be run over or interfere with the control of the tow vehicle.
- Never allow children to operate the tow vehicle or implement, even under adult supervision.
- Never allow children to play on the tow vehicle or implement.
- Use extra caution when backing up. Before the tractor starts to move, look down and behind to make sure the area is clear.

SHUTDOWN & STORAGE

- If engaged, disengage power take-off.
- Park on solid, level ground and lower implement to ground or onto support blocks.
- Put tractor in park or set park brake, turn off engine, and remove switch key to prevent unauthorized starting.
- Relieve all hydraulic pressure to auxiliary hydraulic lines
- Wait for all components to stop before leaving operator’s seat.
- Use steps, grab-handles and anti-slip surfaces when stepping on and off the tractor.
- Detach and store implement in an area where children normally do not play. Secure implement using blocks and supports.

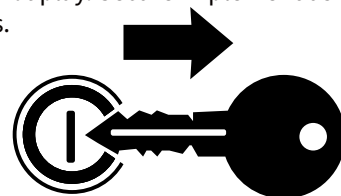

TIRE SAFETY

- Tire changing can be dangerous and must be performed by trained personnel using the correct tools and equipment.
- Always maintain correct tire pressure. Do not inflate tires above recommended pressures shown in the Operator’s Manual.
- When inflating tires, use a clip-on chuck and extension hose long enough to allow you to stand to one side and NOT in front of or over the tire assembly. Use a safety cage if available.
- Securely support the implement when changing a wheel.
- When removing and installing wheels, use wheel handling equipment adequate for the weight involved.
- Make sure wheel bolts have been tightened to the specified torque.
- Some attachments may have foam or sealant inside them and must be disposed of properly.

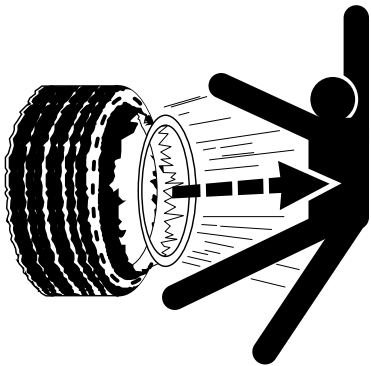

OPERATION SAFETY

- Stay alert for holes, rocks, and roots in the terrain and other hidden hazards. Keep away from drop-offs.
- Stop implement immediately upon striking an obstruction. Turn engine off, remove key, inspect and repair any damage before resuming operation.
- Never operate tractor and implement under trees with low hanging limbs. Operators can be knocked off the tractor and then run over by implement.

TRANSPORT SAFELY

- Comply with federal, state, and local laws.
- Use towing vehicle and trailer of adequate size and capacity. Secure equipment towed on a trailer with tie downs and chains.
- Sudden braking can cause a towed trailer to swerve and upset. Reduce speed if towed trailer is not equipped with brakes.
- Avoid contact with any overhead utility lines or electrically charged conductors.
- Always drive with load on end of loader arms low to the ground.
- Always drive straight up and down steep inclines with heavy end of a tow vehicle with loader attachment on the “uphill” side.

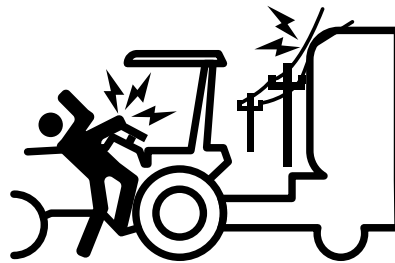

- Engage park brake when stopped on an incline.
- Maximum transport speed for an attached equipment is 20 mph. DO NOT EXCEED. Never travel at a speed which does not allow adequate control of steering and stopping. Some rough terrains require a slower speed.
- As a guideline, use the following maximum speed weight ratios for attached equipment:
 - **20 mph** when weight of attached equipment is less than or equal to the weight of machine towing the equipment.
 - **10 mph** when weight of attached equipment exceeds weight of machine towing equipment but not more than double the weight.
- **IMPORTANT:** Do not tow a load that is more than double the weight of the vehicle towing the load.



PRACTICE SAFE MAINTENANCE

- Understand procedure before doing work. Refer to the Operator’s Manual for additional information.
- Work on a level surface in a clean dry area that is well-lit.
- Lower implement to the ground and follow all shutdown procedures before leaving the operator’s seat to perform maintenance.
- Do not work under any hydraulic supported equipment. It can settle, suddenly leak down, or be lowered accidentally. If it is necessary to work under the equipment, securely support it with stands or suitable blocking beforehand.
- Use properly grounded electrical outlets and tools.
- Use correct tools and equipment for the job that are in good condition.
- Allow equipment to cool before working on it.
- Disconnect battery ground cable (-) before servicing or adjusting electrical systems or before welding on implement.
- Inspect all parts. Make certain parts are in good condition & installed properly.
- Replace parts on this implement with genuine ABI Attachments parts only.
- Do not alter this implement in a way which will adversely affect its performance.
- Do not grease or oil implement while it is in operation.
- Remove buildup of grease, oil, or debris.
- Always make sure any material and waste products from the repair and maintenance of the implement are properly collected and disposed.
- Remove all tools and unused parts before operation.



PREPARE FOR EMERGENCIES

- Be prepared if a fire starts.
- Keep a first aid kit and fire extinguisher handy.
- Keep emergency numbers for doctor, ambulance, hospital, and fire department near phone.



USE SAFETY LIGHTS AND DEVICES

- Slow moving tractors, skid steers, self-propelled machines, and towed equipment can create a hazard when driven on public roads. They are difficult to see, especially at night. Use the Slow Moving Vehicle sign (SMV) when on public roads.
- Flashing warning lights and turn signals are recommended whenever driving on public roads.



AVOID UNDERGROUND UTILITIES

- **Dig Safe, Call 811 (USA)** Always contact your local utility companies (electrical, telephone, gas, water, sewer, and others) before digging so that they may mark the location of any underground services in the area.
- Be sure to ask how close you can work to the marks they positioned.



WEAR PERSONAL PROTECTION EQUIPMENT (PPE)

- Wear protective clothing and equipment appropriate for the job such as safety shoes, safety glasses, hard hat, and ear plugs.
- Clothing should fit snug without fringes and pull strings to avoid entanglement with moving parts.
- Prolonged exposure to loud noise can cause hearing impairment or hearing loss. Wear suitable hearing protection such as earmuffs or earplugs.
- Operating equipment safely requires the operator's full attention. Avoid wearing headphones while operating equipment.



USE SEAT BELT AND ROPS

- ABI Attachments recommends the use of a CAB or roll-over protective structures (ROPS) and seat belt in almost all tow vehicles. Combination of a CAB or ROPS and seat belt will reduce the risk of serious injury or death if the tow vehicle should be upset.
- If ROPS is in the locked-up position, fasten seat belt snugly and securely to help protect against serious injury or death from falling and machine overturn.

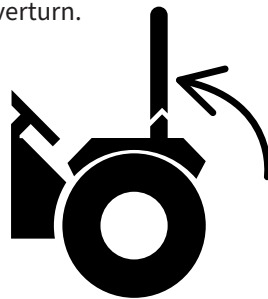

AVOID HIGH PRESSURE FLUIDS HAZARD

- Escaping fluid under pressure can penetrate the skin causing serious injury.
- Before disconnecting hydraulic lines or performing work on the hydraulic system, be sure to release all residual pressure.
- Make sure all hydraulic fluid connections are tight and all hydraulic hoses and lines are in good condition before applying pressure to the system.
- Use a piece of paper or cardboard, NOT BODY PARTS, to check for suspected leaks.
- Wear protective gloves and safety glasses or goggles when working with hydraulic systems.
- DO NOT DELAY. If an accident occurs, see a doctor familiar with this type of injury immediately. Any fluid injected into the skin or eyes must be treated within a few hours or gangrene may result.

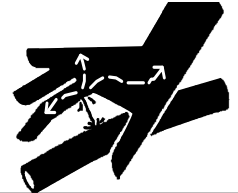

KEEP RIDERS OFF MACHINERY

- Never carry riders on tractor or implement.
- Riders obstruct operator's view and interfere with the control of the tow vehicle.
- Riders can be struck by objects or thrown from the equipment. Never use tractor or implement to lift or transport riders.

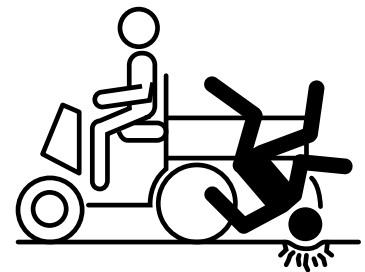

Safety Labels

| | | |
|---|---|---|
|  | ⚠ WARNING 10-10978 | |
| | TO PREVENT SERIOUS INJURY OR DEATH: | |
| <ul style="list-style-type: none">● Avoid unsafe operation and maintenance. Do not operate or work on this machine without reading and understanding the operator's manual.● If manual is lost, call 877-788-7253● Do not allow riders and keep others away during operation. | <ul style="list-style-type: none">● Lower implement, stop low vehicle engine, set park brake and remove ignition key before servicing, adjusting, repairing or unplugging.● Safely support and secure implement before adjustments or repairs are made.● Park or block implement so it will not roll when disconnecting from tow vehicle. | <ul style="list-style-type: none">● Never place any part of the body underneath implement or between movable parts even when the engine has been turned off.● DO NOT operate or transport at high speeds.● DO NOT operate or transport on steep slopes. |

Unpacking Instruction & Setup

Initial Setup Instructions

Tools Needed:

- Gloves
- Safety Glasses
- Safety Shoes
- Tin Snips/ wire cutters
- Hammer
- Crowbar



Removing From Shipping Crate

1. Depending on how the water trailer was ordered, the trailer will either come uncrated on a flat bed or crated and shipped thru an LTL carrier.

If the trailer was shipped on a flat bed, the customer will be responsible for getting the trailer off the flatbed using a tow vehicle (the flat bed will have ramps).

If the trailer was crated, the customer will be responsible for getting the crate off the truck (ex: fork truck).

Once the crate is off the delivery truck, remove the crate ceiling and side walls using a crowbar, hammer or reciprocating saw (sawzall). Recommend this being a 2 or more person job.

2. Cut metal straps (Use caution when cutting metal straps that they do not spring toward you and cause injury)(**Fig 1**).

3. Cut and remove Zip-Ties.

4. Follow the "Initial Setup Instructions" to attach the towing tongue and hitch to the water trailer frame.

Initial Setup Instructions

Tools Needed:

- Gloves
- Safety Glasses
- Safety Shoes
- (2) 3/4" wrenches (or socket set)

1. Remove Trailer tongue from frame behind plumbing/engine.

2. Remove (4) 1/2-13 bolts, (8) 1/2" washers and (4) 1/2-13 nuts from box that hitch is packed in.

3. Position Tongue so that the long end of the Tow Bar Adjustment Bracket is facing toward the ground and bolt holes in tongue lined up with bolt holes in frame (**Fig 2**). Install (1) washer onto all 4 bolts, then insert bolts into frame and tongue. Slide (1) washer onto each bolt then thread nut onto bolt. Tighten nuts using (2) 3/4" wrenches (or sockets).



Fig 1.

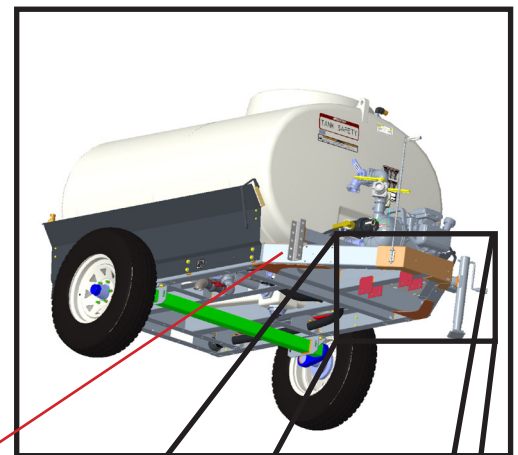

Fig 2.

Tongue in shipping position

With tongue in position, install bolts, washers and nuts.

Tongue in position with Tow Bar Adjustment Bracket facing toward ground.

Setup (cont'd)

Hitch Installation to Tow Bar Adjustment Bracket

Tools Needed:

- Gloves
- Safety Glasses
- Safety Shoes
- (2) 15/16" wrenches (or socket set)

There are 3 styles of hitches to choose from. Below are the procedures to mount each one.

Option 1 - P/N 10-90630 - 2 5/16" Ball Hitch Coupler

Slide Ball Hitch Coupler into Tow Bar Adjustment Bracket at desired height. Slide (1) 5/8" washer onto each 5/8-11 x 5" long bolt. Slide the (2) bolts thru holes in bracket and hitch. Slide (1) 5/8" washer onto each bolt then thread 5/8-11 Nylock nuts onto bolts and tighten using (2) 15/16" wrenches or socket set.



Option 2 - P/N 10-90631 - Asm: Hitch Clevis Hitch Pin

Slide Hitch Clevis into Tow Bar Adjustment Bracket at desired height. Slide (1) 5/8" washer onto each 5/8-11 x 5" long bolt. Slide the (2) bolts thru 1st holes in bracket then slide (1) 5/8" washer onto each bolt then continue sliding bolts thru hitch. Slide (1) 5/8" washer onto each bolt then slide bolts thru holes in 2nd bracket. Slide (1) 5/8" washer onto each bolt then thread 5/8-11 Nylock nuts onto bolts and tighten using (2) 15/16" wrenches or socket set.

Place washer on either side of bracket on both bolts.

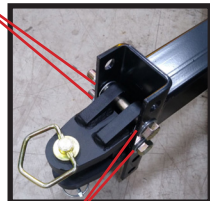

Place washer on either side of bracket on both bolts.

Option 3 - P/N 10-90632 - Hitch - Pentle (Ring Hitch)

Slide Pentle Hitch into Tow Bar Adjustment Bracket at desired height. Slide (1) 5/8" washer onto each 5/8-11 x 5" long bolt. Slide the (2) bolts thru holes in bracket and hitch. Slide (1) 5/8" washer onto each bolt then thread 5/8-11 Nylock nuts onto bolts and tighten using (2) 15/16" wrenches or socket set.



Hooking up the Water Trailer to your Tow Vehicle

1. Back the tow vehicle up to the trailer until the ball on the receiver hitch attached to tow vehicle is under the Ball hitch (or Clevis or Pentle hitch) on the trailer then lower the trailer by cranking the handle on the jack until the hitch is fully seated on the tow vehicle receiver ball. If you have a ball hitch style, be sure to lift and pull back the ball hitch locking tab, on top of the ball hitch (Fig 3), so the ball hitch will fully seat on the receiver ball then lower and release the ball hitch locking tab so the ball will be fully secure within the ball hitch. Continue cranking the handle on the jack until the jack is no longer touching the ground.

Idealy, you should adjust the height of your hitch so that the trailer frame is parallel with the ground when being towed. If your trailer frame is not parallel to the ground when hooked to the tow vehicle, crank the jack handle and raise the trailer until the hitch is no longer touching the tow vehicle receiver ball. Unloosen the bolts and nuts using (2) 15/16" wrenches or socket set and remove the bolts while holding on to the hitch (so it won't drop).

Align the 2 mounting holes on your hitch with the 2 holes on the Tow Bar Adjustment Bracket (Fig 4) that makes your trailer level to the ground, then slide the (2) bolts thru the holes in bracket and hitch (be sure there is a washer on each bolt before sliding bolts into the holes).

Slide (1) 5/8" washer onto each bolt then thread 5/8-11 Nylock nuts onto bolts and tighten using (2) 15/16" wrenches or socket set.

Torque bolts to 150-180 ft-lbs.

If your hitch has to be mounted higher on the trailer tongue than any of the holes in the Tow Bar Adjustment Bracket has, the tongue can be removed from the frame and flipped so the long end of the Tow Bar Adjustment Bracket on the tongue is facing upwards. See "Initial Set Up Instructions" on page 7 explaining how to mount the tongue to the frame.

2. Crank the jack handle in the opposite direction to lower the trailer hitch back onto the tow vehicle receiver ball, then continue crank the jack handle to raise the jack up off the ground then release the locking portion of the jack pin and pull the pin out of the jack and swivel the jack up so it's parallel to the trailer frame. Reinsert the jack pin back into the jack and re-clip the locking portion of the jack pin to lock the jack into the "stowed" position (Fig 6).

Jack MUST be locked in "stowed" position when trailer is hooked to a tow vehicle.

Setup (cont'd)

Unhooking up the Water Trailer from your Tow Vehicle

1. To unhook the trailer from the tow vehicle, unlock the portion of the jack pin and pull the pin out of the jack then swivel the jack to its vertical position. Push the pin back into the jack and re-lock the pin. Crank the jack handle to raise the jack until the hitch lifts up off the receiver ball on the tow vehicle. If you have a ball hitch style on the trailer, be sure to lift and pull back on the ball hitch locking tab so the ball hitch can come off the receiver ball. Continue cranking the jack handle until the hitch is completely free of the tow vehicles receiver ball.

Water Tank Lid

Confirm Tank lid opens correctly:

When closed, locking tabs should line up (Fig 7) **(Recommend securing lid with lock to prevent anyone from accidentally falling in)**. To open, Twist lid counter-clockwise until it stops (locking tabs are NOT aligned) (Fig 8) and open lid. To shut, close lid and twist lid clockwise until it stops (locking tabs will line up).



DANGER
At no time should anyone enter the water tank.

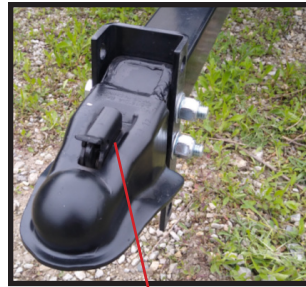

Fig 3.

Ball Hitch
Locking Tab

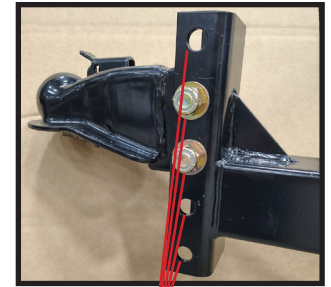

Fig 4.

Holes in the Tow Bar
Adjustment Bracket



Fig 5.



Fig 6.

When water trailer is attached to the tow vehicle, hand crank until jack stand is off the ground. Pull pin and swivel jack up into "stowed" position and replace and lock pin.

Locking tabs
lined up



Fig 7.

Locking tabs
NOT lined up



Fig 8.



Operation Guide

Filling the tank by garden hose

Source valve should be on "Tank Supply" position (end of handle pointing toward tank) as shown in (Fig 9). On top of the water tank, toward the front is a swivel garden hose connection port (Fig 10). Thread Lawn garden hose onto fitting and turn water on. When tank is full, water will automatically stop filling when float in valve is tripped. Turn water supply off and remove garden hose from tank.

Starting Engine

NOTE:

Before starting engine, The pump must be full of water. Fill tank with Garden hose so the water line in tank is at least above the top of the pump (you must remove the cap on top of the pump while filling the tank to bleed the air out of the pump) (see Fig 11) - **RUNNING THE PUMP WITHOUT IT BEING FULL OF WATER WILL DAMAGE THE PUMP.**

The pump is full when water seeps out of the top of the pump as you unscrew the cap. Tighten cap after pump is confirmed full. Put valve handles in recommended positions in procedure below (see Fig 19).

Confirm pump is full of water (Fig 11).

Make sure Source valve handle is in "Tank supply" position (end of handle facing tank) (Fig 19).

Recirculation valve handle 1/4 to fully open (Fig 19).

Close Spray Hose valve handle (Fig 19).

Close rear sprayer valve. There is a silver tab on the valve handle that will turn at 90-degree turns when pull cord is pulled. When the silver tab is perpendicular with the plumbing, the valve is closed (Fig 17). When the silver tab is parallel with the plumbing, the valve is opened (Fig 18).

Confirm Fuel tank has gasoline (Fig 12). Move fuel lever to far right (Fig 14).

Confirm the proper amount of oil is in the engine. There are 2 Oil fill ports, 1 located on the front side of the engine and 1 on the back close to where the engine and pump mate (Fig 15 & 16) (check engine manual for proper oil type for the region you live in).

Flip engine ON/OFF switch to "ON" (Fig 13).

Move choke lever to left (Fig 14).

Move Throttle lever far left (lever next to "rabbit" symbol) (Fig 14).

Pull engine cord until engine starts then push choke lever back to right (Fig 12).

To stop engine, move throttle lever to far right (lever next to "turtle" symbol) (Fig 14) then flip engine ON/OFF switch to "OFF" position (Fig 13).

End of Tank Supply handle pointing toward tank.

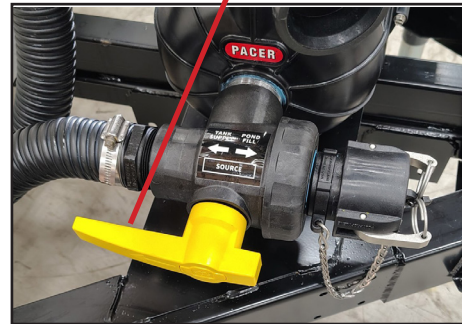

Fig 9.



Hose Fill

Fig 10.

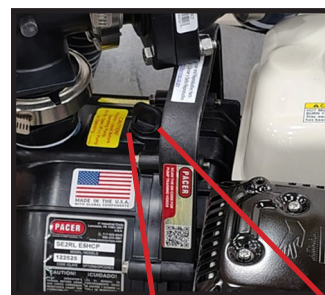

Fig 11.

Pump Bleed Cap

Loosen cap so Water will seep when filling tank indicating pump is full of water and free of air. Re-tighten cap when water starts to seep.

Operation Guide (cont'd)

Filling the tank from pond or other water supply with optional Pond Fill Hose

Before filling tank from a pond or external water source, there should be enough water in the tank so that water seeps out of the port on top of the pump when the cap is unscrewed (**Fig 11**). **RUNNING THE PUMP WITHOUT BEING FULL OF WATER WILL DAMAGE THE PUMP.**

The pump is full when water seeps out of the top of the pump as you unscrew the cap. Tighten cap after pump is confirmed full. Put valve handles in recommended positions in procedure below (**Fig 19**).

Confirm pump is full of water (**Fig 11**).

With engine OFF, remove End Cap from Source valve by unlatching both cam-locks. (**Fig 20**).

Rotate Source valve handle to "Pond Fill" position (end of handle facing away from tank) (**Fig 21**)

Unhook Straps securing hoses to tank frame. Lay Pond Fill hose on ground and remove Hose Plug from camlok (**Fig 22**). Attach end of pond fill hose to "Pond Fill" valve. Fully seat hose onto valve and secure by closing both cam-locks (**Fig 23**).

Place other end of Pond Fill hose in pond or some other water source.

Recirculation valve handle 1/4 to fully open (**Fig 25**).

Close Spray Hose valve handle (**Fig 25**).

Close rear sprayer valve. There is a silver tab on the valve handle that will turn at 90-degree turns when pull cord is pulled. When the silver tab is perpendicular with the plumbing, the valve is closed (**Fig 17**). When the silver tab is parallel with the plumbing, the valve is opened (**Fig 18**).

Refer to "Starting Engine" section to start engine. When finished Filling tank, rotate source valve handle back to "Tank Fill" position. Stop engine by moving throttle lever to closed position (lever next to "turtle" symbol (**Fig 14**)). Flip engine ON/OFF switch to "OFF" position (**Fig 13**).

When finished Filling tank, rotate source valve handle back to "Tank Fill" position (**Fig 24**). Stop engine by moving throttle lever to closed position (lever next to "turtle" symbol (**Fig 14**)). Remove hose from pond. Unhook hose from valve and replace end cap. Secure end cap to Source valve by latching both cam-locks (**Fig 24**). Strap hose back



Fig 12.

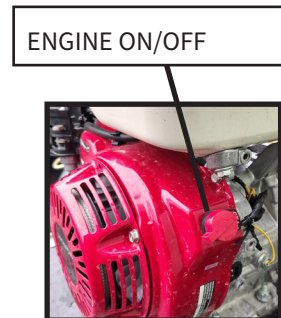

Fig 13.

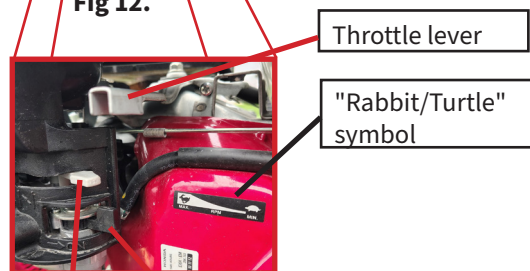

Fig 14.

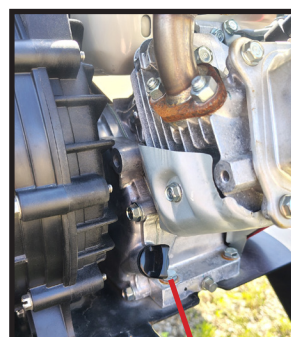

Fig 15.



Fig 16.



Fig 17.

Silver tab on valve is perpendicular to plumbing when valve is closed.

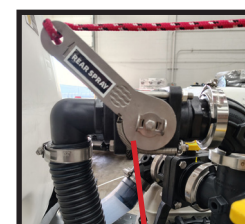

Fig 18.

Silver tab on valve is parallel to plumbing when valve is opened.

Operation Guide (cont'd)

Rear sprayer on/off pull cord

Recirculation valve handle. Handle perpendicular to valve is closed. Handle in line with valve is open.

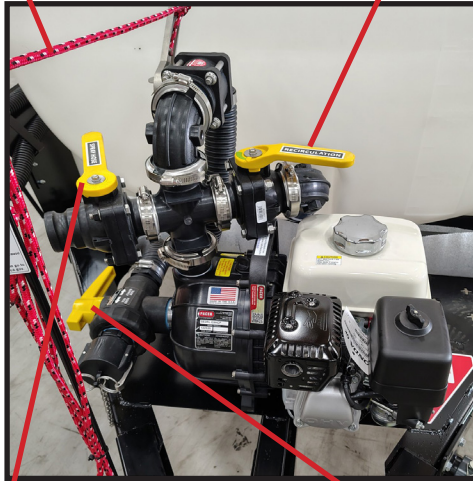

Fig 19.

Sprayer hose valve handle. Handle perpendicular to valve is closed. Handle in line with valve is open.

Source valve handle facing toward tank

Operation Guide (cont'd)

Using Spray hose (P/N 10-90573)

Before starting the engine, there should be enough water in the tank so that water seeps out of the port on top of the pump when the cap is unscrewed (**Fig 19**). **RUNNING THE PUMP WITHOUT BEING FULL OF WATER WILL DAMAGE THE PUMP.** The pump is full when water seeps out of the top of the pump as you unscrew the cap. Tighten cap after pump is confirmed full.

Confirm pump is full of water (**Fig 11**).

Confirm Source valve handle is in "Tank Supply" position (end of handle facing toward tank) (**Fig 19**).

Unhook Straps securing hoses to tank frame. Lay Spray hose (P/N 10-90573) on ground and attach end of spray hose to "Spray Hose" valve (Spray hose handle on valve should be closed at this time). Fully seat hose onto valve and secure by closing both cam-locks (**Fig 26**).

Recirculation valve handle 1/4 to fully open (**Fig 19**).

Close rear sprayer valve. There is a silver tab on the valve handle that will turn at 90-degree turns when pull cord is pulled. When the silver tab is perpendicular with the plumbing, the valve is closed (**Fig 17**). When the silver tab is parallel with the plumbing, the valve is opened (**Fig 18**).

Refer to "Starting Engine" section to start engine.

TO AVOID POSSIBLE INJURY, Grab hold of spray hose by nozzle before turning spray hose handle on valve to "open" position. Turn spray hose handle on valve to fully "open" position (**Fig 28**).

While using spray hose, regulate the water pressure by adjusting the Recirculation valve handle. When Recirculation valve handle is fully closed, more water pressure will come out the spray hose nozzle. The more fully open the Recirculation valve handle is, less water pressure will come out the spray hose nozzle (**Fig 29**).

Adjust the spread of the water coming out of the spray hose nozzle by twisting the end of the nozzle. Twisting the end of the nozzle clockwise creates a tighter spray stream. Twisting the end of the nozzle counter-clockwise widens the spray stream (**Fig 30**).

When finished spraying, turn spray valve handle to "closed" position (**Fig 25**). Stop engine by moving throttle lever to closed position (lever next to "turtle" symbol (**Fig 14**)). Make sure Recirculation valve handle is at least 1/4 to fully open position. Unhook hose from valve. Strap hose back onto water trailer frame.

CAUTION:

Do not let your tank go empty when spraying. RUNNING THE PUMP WITHOUT BEING FULL OF WATER WILL DAMAGE THE PUMP.



Fig 20.



Fig 21.



Fig 22.



Fig 23.



Fig 24.

Rear sprayer on/off pull cord

Recirculation valve handle. Handle perpendicular to valve is closed. Handle in line with valve is open.



Fig 25.

Sprayer hose valve handle. Handle perpendicular to valve is closed. Handle in line with valve is open.

Source valve handle facing away from tank.

Operation Guide (cont'd)



10-90573 Spray hose with nozzle



Cam-locks to secure spray hose to valve - fully seat hose onto valve before latching cam-locks.

Fig 26.



Fig 27.



Fig 28.



Fig 29.



Fig 30.

Storing Spray hose

There are brackets on each corner of the trailer. The front two brackets have bungee cords. Disconnect Spray hose from Spray hose valve. Wrap Spray hose around tank with the hose inside the brackets. Pull both bungee cords over the top of hose and hook to lower edge of trailer side panel.



Wrap Spray hose around tank inside the brackets on each corner. Secure hose in both front corners with bungee cords.

Operation Guide (cont'd)

Using Rear Sprayer

Before starting the engine, there should be enough water in the tank so that water seeps out of the port on top of the pump when the cap is unscrewed (Fig 19). **RUNNING THE PUMP WITHOUT BEING FULL OF WATER WILL DAMAGE THE PUMP.** The pump is full when water seeps out of the top of the pump as you unscrew the cap. Tighten cap after pump is confirmed full.

Confirm pump is full of water (Fig 11).

Confirm Source valve handle is in "Tank Supply" position (end of handle facing toward tank) (Fig 19).

Recirculation valve handle 1/4 to fully open (Fig 19).

Sprayer hose valve handle is in "closed" position (Fig 19).

Close rear sprayer valve. There is a silver tab on the valve handle that will turn at 90-degree turns when pull cord is pulled. When the silver tab is perpendicular with the plumbing, the valve is closed (Fig 17). When the silver tab is parallel with the plumbing, the valve is opened (Fig 18).

Refer to "Starting Engine" section to start engine.

Pull rear spray valve cord and release to start water flow (Fig 31).

While using the rear sprayer, regulate the water pressure by adjusting the Recirculation valve handle. When Recirculation valve handle is fully closed, more water pressure will come out the rear sprayer. The more fully open the Recirculation valve handle is, less water pressure will come out the rear sprayer (Fig 19).

When finished spraying, pull rear sprayer cord and release to stop water flow (Fig 31). Stop engine by moving throttle lever to closed position (lever next to "turtle" symbol (Fig 14). Flip engine ON/OFF switch to "OFF" position (Fig 13). Make sure Recirculation valve handle is at least 1/4 to fully open position.

CAUTION:

Do not let your tank go empty when spraying. RUNNING THE PUMP WITHOUT BEING FULL OF WATER WILL DAMAGE THE PUMP.



Rear sprayer pull cord

Fig 31.



Draining your tank

Drain port and valve are located under the trailer frame in front of the right tire.

Turn drain valve handle 90 degrees counter-clockwise to open. Once tank is empty, Turn drain valve handle 90 degrees clockwise to close (Fig 31 and 32).

If draining for storage and or freezing conditions, drain water out of pump by opening drain port on underside of pump. Once empty, retighten drain port. (Fig 33).



Fig 32.

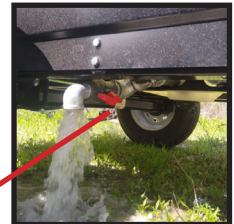

Fig 33.

Tank drain valve

Pump drain port



Fig 34.

- If complete tank drainage is desired, remove drain plug (P/N 10-11032) on underside of tank).



P/N 10-11032
Drain Plug on
underside of
water tank (550
option only)

Specifications

| COMPONENT | DESCRIPTION | |
|-----------------------------------|--|---|
| Tank Capacity | 340 Gallons | 550 Gallons |
| Empty Weight | 661 lbs | 1200 lbs |
| Unit Weight With Tank Full | 3498 lbs | 5800 lbs |
| Unit Length | 134" | 141" |
| Unit Width | 64" | 79" |
| Unit Height | 52" | 68" |
| Min. Tractor H.P. (Level Terrain) | 24 H.P. 4WD | 35 H.P. 4WD |
| Frame Construction | Welded Tube Steel 2-1/2" Tall X 31-1/2" Wide x 1/4" Thick | Welded Channel Steel 5" Tall X 3" Wide x 3/16" Thick |
| Ground Clearance | 10"-11" at Hitch and Wheels | Wall 12" At Wheels - 8" At Hitch |
| # of Tires | 2 (Two) | 2 (Two) |
| Tires | Tire Size: ST205/75R14D | Tire Size: ST255/80R16E |
| Rims | 14" Diameter x 5 1/2" Wide | 16" Diameter x 7 1/2" Wide |
| Hitch Type | Optional: 2 5/16" Ball or 5/8" Pin or Pentle | Optional: 2 5/16" Ball or 5/8" Pin or Pentle |
| Hitch Height | Adjustable From 11-3/4" -21" | Adjustable From 8.5" -17" |
| Tank Type | Elliptical Rotationally Molded | Elliptical Rotationally Molded |
| Tank Color | White | White |
| Tank Drainage | Full Drain | Full Drain |
| Tanks Top Opening | 16 " around with vented lid | 16 " around with vented lid |
| # of Spray Nozzles | 1 (One) | 2 (Two) |
| Rear Nozzle Type | Brass - Flooding, 1" NPT | Brass - Flooding, 1" NPT |
| Spray Coverage | around 3' -12' | 6' - 20' |
| Motor Brand | Honda | Honda |
| Motor Power | 160cc Displacement 6.9 lb-ft Torque Net, 4.6 HP Net | 160cc Displacement 6.9 lb-ft Torque Net, 4.6 HP Net |
| Pump Brand | Pacer | Pacer |
| Pump Construction | 2" Polypropylene | 2" Polypropylene |
| Priming | Self-Priming | Self-Priming |
| Spray Hose | Standard | Standard |
| Quick Fill System | Optional | Optional |
| D.O.T. Compliant | No | No |

Basic Operations

| INDOOR | WEEKLY | OUTDOOR | WEEKLY |
|-------------|----------------|-------------|----------------|
| 80' X 100' | 50-800 GAL. | 60' ROUND | 800-1200 GAL. |
| 100' X 150' | 1000-1500 GAL. | 150' X 200' | 2000-3000 GAL. |
| 150' X 200' | 1500-3000 GAL. | 180' X 300' | 4000-5000 GAL. |

Numbers are averages. Footing, drainages and climate will determine proper application for a specific arena.

340 GALLON

550 GALLON

REAR SPRAY SYSTEM

| RECIRCULATION VALVE SETTINGS | FLOW RATE GPM | MINS. TO EMPTY FROM FULL |
|------------------------------|---------------|--------------------------|
| Valve Fully Open | 49 | 6:15 |
| Valve 3/4 Open | 54 | 5:45 |
| Valve 1/2 Open | 62 | 5:00 |
| Valve 1/4 Open | 80 | 4:00 |
| Valve Fully Closed | 86 | 3:30 |

SPRAY HOSE

| RECIRCULATION VALVE SETTINGS | FLOW RATE GPM | MINS. TO EMPTY FROM FULL |
|------------------------------|---------------|--------------------------|
| Valve Fully Open | 31 | 10:00 |
| Valve 3/4 Open | 33 | 9:15 |
| Valve 1/2 Open | 39 | 8:00 |
| Valve 1/4 Open | 45 | 7:00 |
| Valve Fully Closed | 47 | 6:30 |

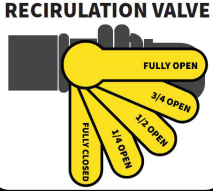

RECIRCULATION VALVE

WWW.ABIATTACHMENTS.COM

877-788-7253

WWW.ABISUPPORT.COM

PROUDLY MANUFACTURED IN THE USA

*Approximate time and GPM shown. Your results may vary.

REAR SPRAY SYSTEM

| RECIRCULATION VALVE SETTINGS | FLOW RATE GPM | MINS. TO EMPTY FROM FULL |
|------------------------------|---------------|--------------------------|
| Valve Fully Open | 43 | 12:00 |
| Valve 3/4 Open | 68 | 7:45 |
| Valve 1/2 Open | 90 | 5:45 |
| Valve 1/4 Open | 104 | 5:00 |
| Valve Fully Closed | 115 | 4:30 |

SPRAY HOSE

| RECIRCULATION VALVE SETTINGS | FLOW RATE GPM | MINS. TO EMPTY FROM FULL |
|------------------------------|---------------|--------------------------|
| Valve Fully Open | 21 | 25:15 |
| Valve 3/4 Open | 27 | 19:15 |
| Valve 1/2 Open | 39 | 13:15 |
| Valve 1/4 Open | 46 | 11:15 |
| Valve Fully Closed | 49 | 10:30 |

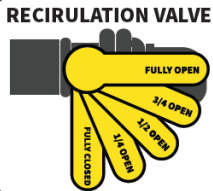

RECIRCULATION VALVE

WWW.ABIATTACHMENTS.COM

877-788-7253

WWW.ABISUPPORT.COM

PROUDLY MANUFACTURED IN THE USA

*Approximate time and GPM shown. Your results may vary.

Maintenance

Lubricating Wheel Hubs

The grease zerk to lube the bearing hub is located behind the rubber cap in the center of the hub. Pull off the rubber cap and pack the bearing full of grease then put the rubber cap back on. The bearing in each of the hubs should be greased every 6 months. They should also be greased before any long period of storage. (**Fig 35-36**).



Tire Pressure:

Tire pressure should be 65 psi (cold) on the 340 Gal and 80 psi (cold) on the 550 Gal. Check pressure once a month or if tire visually looks low. Fill with air if low.

Lug Nut Torque Spec:

Lug nuts should be torques to 90 ft/lbs. Check lug nuts once a month.

Pump/Engine:

Refer to the manuals provided by the pump and engine manufacturer for maintenance instructions for the respective components. This can be located in the document holder connected to the frame on the front of the Water Trailer (**Fig 37**).

- Never run the Motor and Pump for long periods of time without water in the system. Operating the Pump and Motor while the system is empty may result in damage to the Pump seals or impeller. When the Water Trailer is empty shut off the Motor to prevent any damage to the Pump and Motor.
- Always use a gas stabilizer in the gas used in the engine for the Water Trailer. Failure to use gas stabilizer in the fuel may result in issues with the engine functionality.
- Always follow Manufacturer suggested maintenance requirements and manufacturer recommendations for any replacement parts.
- Check oil level before any use to ensure the oil level is at proper operational levels. See Manufacturers guide for information on oil types and levels.



Fig 37.

Manual/Instructions document holder

Winterizing Preparation:

The drain port and valve are located under the trailer frame in front of the right tire (**Fig 38 and 39**).

Turn drain valve handle 90 degrees counter-clockwise to open.

Remove drain plug and weep hole plug on pump (**Fig 40**).

When tank has 2 to 3 gallons of water left in it, turn drain valve handle 90 degrees clockwise to close.

Re-thread drain plug and weep plug back on to the pump.



Fig 38.

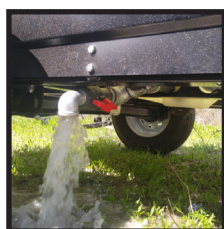

Fig 39.

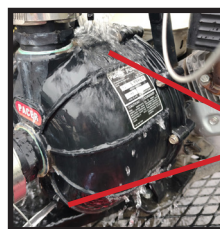

Fig 40.

Drain and Weep plugs on pump

Maintenance (cont'd)

Winterizing Preparation (cont'd):

Pour 2 to 4 gallons of pink RV antifreeze into tank. Confirm spray hose valve and rear sprayer valve are closed. Confirm source valve handle is in "Tank Supply" position. Confirm Recirculation valve handle is in open position. Start engine and let water circulate thru the system a few minutes then open rear sprayer valve and let some antifreeze spray thru the rear sprayer nozzles then close rear sprayer valve. Open the spray hose valve for a few seconds to allow some antifreeze to run thru the valve then close valve. Turn the Source valve handle to "Pond Fill" then back to "Tank Supply" position. Shut engine off. There is lubrication in the antifreeze. Running antifreeze thru the system and valves will lubricate the seals within the valves and add longer life to the valves. Leave about 2 gallons of the RV Antifreeze in the tank to store for winter.

*** Failure to properly Winterize/Freeze Protect your Water Trailer may result in damage to the Water Trailer components that may not be covered by Manufacturer Warranty. Be sure to properly flush already winterized units before use.***

Fuel Tank Preparation for prolong storage:

To prevent the fuel from breaking down and or gumming up the carburator from sitting for a prolong time, it's recommended to drain the fuel from the tank. Start the engine and let it run until it runs out of gas.

Replacement Parts

1. In the event the water trailer lid gets damaged, 10-11233 LID W/BRKT: WATER TRAILER TANK, 340/550 GAL can be ordered. Use the existing hardware when replacing the lid onto the water tank.

If your lid has a gasket between the tank and lid that gets torn, it does NOT need to get replaced.

Remove gasket and apply thick ring of silicone around the entire mounting surface before mounting lid to water tank.

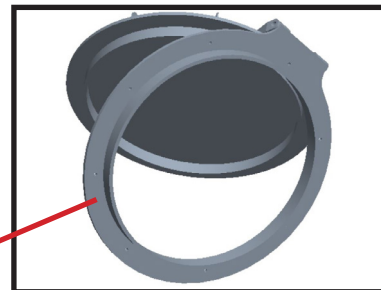
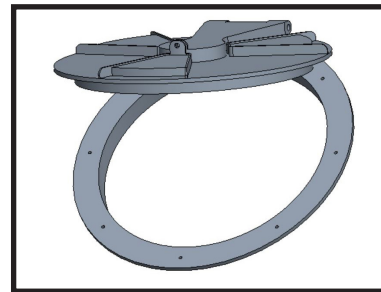

Apply thick ring of silicone around this entire surface before mounting lid to water tank.

Troubleshooting & FAQs

Ratcheting Valve on Rear Sprayer Information:

The Ratcheting Valve works on a spring and pin system. The spring located on the outside of the handle returns the handle back to neutral after every pull. Pulling the handle past the designed distance to turn the ball valve may damage the spring. Additionally, the pin on the inside of the handle may become damaged, or the housing around the pin or retainer points may become damaged. ABI advises taking time to familiarize the operator with how to operate the Ratcheting Valve prior to operation. The silver tab on the valve handle (**Fig 41 and 42**) will turn at 90-degree turns when pull cord is pulled indicating that the ball inside the valve has been properly turned. When the silver tab is perpendicular with the plumbing, the valve is closed. When the silver tab is parallel with the plumbing, the valve is opened.

The Ratcheting Valve handle is bolted to the valve body via a bolt. This bolt should be snug but never tight. If the bolt is tightened down fully it will prevent the spring from pulling the handle back to neutral. If the bolt is too loose then the handle will not turn properly and may cause the pin inside the handle to fall out. The bolt is factory set and should not be adjusted, unless the handle

Silver tab on valve is perpendicular to plumbing when valve is closed.



Fig 41.

Silver tab on valve is parallel to plumbing when valve is opened.

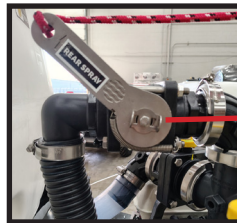

Fig 42.

If Algae starts to form inside the tank:

If algae starts to form inside your tank, fill the tank about 2/3 full and add 1 or 2 gallons of bleach. Let set for a couple hours then tow the trailer around to agitate the water then drain the water out the drain valve in front of the right tire. To get the remaining small amount of bleach water out of the tank (on the 550 only), remove the drain plug at the bottom center of the tank (Item P/N 10-11032 on page 15) so as not to run the algae/bleach water thru the pump and valves. Rinse with fresh water before filling then shut drain valve in front of right tire and re-tighten 10-11032 plug back onto the underside of the tank.

SAFETY INSPECTION CHECK LIST:

The following items should be inspected before use:

- Check for Water leakage from tank, valves, piping, or hoses.
- Inspect hoses for any tears or damage to hoses or connectors.
- Check ratcheting valve rope on rear sprayer valve for any damage.
- Check engine for fuel or oil leakage – if found refer to engine manufacturer manual.
- Check engine for fuel level and oil level before operating the motor. Refer to engine manufacturer manual for running instructions.
- Inspect hand jack for any damage and ability to raise or lower the Water Trailer.
- Check tow receiver, safety chains, and hooks for any damage.
- Check wheels, and rims for damage. Check lugs or studs to ensure they are tight.
- Check tires for proper air pressure. Refer to PSI rating on the tire for proper air pressure.

CAUTION: Correct any discovered defects before continuing use!

Options

10-90574 Pond Fill Hose

Optional Pond Fill Hose is used to extract water from a pond (or other external water supply) to fill the water tank. Procedure to use the Pond Fill Hose is explained in the Operational Guide section on pages 11-12.



When not in use, store the Pond Fill Hose with the Spray Hose that is described in the Operational Guide section on page 13.

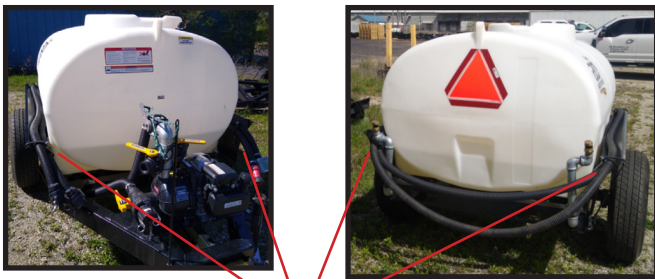

Wrap hose(s) around tank inside the brackets on each corner. Secure hose(s) in both front corners with bungee cords.

10-90581 Extension Hose (20ft)

Optional Extension Hose can be used to extend the Sprayer Hose reach or Hose Pond Fill reach.



10-90575 Garden Hose Adapter

Optional Garden Hose Adapter can be used in place of the Hose Sprayer when a garden hose is desired. Attach the Garden Hose Adapter to the Hose Sprayer valve in the same way as the Hose Sprayer would attach. Screw a garden hose to the fitting on the adapter and use the garden hose the same way the sprayer hose is used described in the Operational Guide section on pages 12-13.



CONTACT INFORMATION

ABI Attachments, Inc
520 S. Byrkit Ave.
Mishawaka, IN 46544

CUSTOMER SUPPORT

Phone: 877-788-7253
Hours: Monday - Friday | 9AM - 5PM EST
Email: abcustomerservice@abiattachments.com
Web: abiattachments.com/support

For additional information on this equipment, or to order replacement parts, please contact our Customer Support Team at 877-788-7253 to speak with one of our representatives.

Additional support videos are available at the ABI Support Page under each tool.

Warranty and return policy information can also be found on the ABI Support Page under each tool. For additional questions regarding warranty or return policy, please contact our Customer Support Team at 877-788-7253 to speak with one of our representatives.



ABI[®]
ATTACHMENTS

© 2025 ABI Attachments, Inc.