



OWNERS MANUAL

ABI DRAGMASTER HORIZON ARENA DRAG



*This instruction document covers several models. Features may vary by model.
Not all features in this document are applicable to all models and the model depicted may differ from yours.*

[**VIEW ABI SUPPORT WEB PAGE**](#)



TABLE OF CONTENTS

FOR YOUR RECORDS.....	2	RAIL BLADE INITIAL ASSEMBLY.....	19
MODEL AND SERIAL NUMBER	2	FIRST USE - CONNECTIONS.....	21
TABLE OF CONTENTS	3	CUTTING PTO SHAFT TO LENGTH	21
SAFETY	4	CONNECTING PTO SHAFT.....	21
SAFETY LABELS	8	CONNECTING DRAG TO TRACTOR	22
PARTS AND CONTROLS.....	9	CONNECTING HYDRAULIC SYSTEM ...	22
FEATURES EXPLAINED	10	FIRST USE - ADJUSTMENTS	23
340 GALLON WATER TANK.....	10	ADJUSTING HITCH HEIGHT.....	23
RAPID-SET HANDLES.....	10	ADJUSTING WATER PUMP	24
SPRAY HOSE	10	ADJUSTING FRAME HEIGHT.....	25
HYDRAULIC TONGUE ASSEMBLY	10	SETTING RAKE STOPS	26
HYDRAULIC LEVEL BLADE.....	10	ADJUSTING PROFILE BLADES.....	28
RAPID-SET SCARIFIERS	10	ADJUSTING GROOMING RODS.....	28
HYDRAULIC WHEEL LIFT	11	ADJUSTING SCARIFIERS	28
RAPID-SET PROFILE BLADES.....	11	ADJUSTING LEVEL BLADE	28
RAPID-SET GROOMING RODS.....	11	RAPID SET HANDLES EXPLAINED.....	29
FLOATING FINISH RAKE.....	11	DEPTH CHART SETTINGS.....	31
RECIRCULATING WATER VALVE.....	11	MAINTENANCE.....	32
LEVEL BLADE HAND PUMP	11	GREASE.....	32
UNLOADING YOUR EQUIPMENT	12	WINTERIZING	32
10FT INITIAL ASSEMBLY.....	14	OPERATOR CHECKLIST.....	33
LEVEL BLADE	14	REPLACEMENT PARTS.....	34
SCARIFIERS	15	SPECIFICATIONS.....	35
PROFILE BLADES	16	EXPLODED VIEWS FOR ASSEMBLY	41
GROOMING RODS	17		
RAKE	18		

SAFETY



WARNING! The SAFETY ALERT SYMBOL indicates there is a potential hazard to personal safety involved and extra safety precaution must be taken. When you see this symbol, be alert and carefully read the message that follows it. In addition to design and configuration of equipment, hazard control, and accident prevention are dependent upon the awareness, concern, prudence, and proper training of personnel involved in the operation, transport, maintenance, and storage of equipment.



CALIFORNIA PROPOSITION 65

WARNING! Cancer and reproductive harm - www.P65Warnings.ca.gov

SAFETY AT ALL TIMES

Careful operation is your best assurance against an accident. All operators, no matter how much experience they may have, should carefully read this manual and other related manuals, or have the manuals read to them, before operating the tow vehicle and this implement.

- Thoroughly read and understand the "Safety Label" section. Read all instructions noted on them.
- Do not operate the equipment while under the influence of drugs or alcohol as they impair the ability to safely and properly operate the equipment.
- The operator should be familiar with all functions of the tow vehicle and attached implement and be able to handle emergencies quickly.
- Make sure all guards and shields appropriate for the operation are in place and secured before operating implement.
- Keep all bystanders away from equipment and work area.
- Start tow vehicle from the driver's seat with hydraulic controls in neutral.
- Operate tow vehicle and controls from the driver's seat only.
- Never dismount from a moving tow vehicle or leave tow vehicle unattended with engine running.
- Do not allow anyone to stand between tow vehicle and implement while backing up to implement.
- Keep hands, feet, and clothing away from power-driven parts.
- While transporting and operating equipment, watch out for objects overhead and along side such as fences, trees, buildings, wires, etc.
- Do not turn tow vehicle so tight as to cause hitched implement to ride up on the tow vehicle's rear wheel.
- Store implement in an area where children normally do not play. When needed, secure attachment against falling with support blocks.

SAFETY PRECAUTIONS FOR CHILDREN

Tragedy can occur if the operator is not alert to the presence of children. Children generally are attracted to implements and their work.

- Never assume children will remain where you last saw them.
- Keep children out of the work area and under the watchful eye of a responsible adult.
- Be alert and shut the implement and tractor down if children enter the work area.
- Never carry children on the tractor or implement. There is not a safe place for them to ride. They may fall off and be run over or interfere with the control of the tow vehicle.
- Never allow children to operate the tow vehicle, even under adult supervision.
- Never allow children to play on the tow vehicle or implement.
- Use extra caution when backing up. Before the tractor starts to move, look down and behind to make sure the area is clear.

SHUTDOWN & STORAGE

- If engaged, disengage power take-off.
- Park on solid, level ground and lower implement to ground or onto support blocks.
- Put tractor in park or set park brake, turn off engine, and remove switch key to prevent unauthorized starting.
- Relieve all hydraulic pressure to auxiliary hydraulic lines.
- Wait for all components to stop before leaving operator's seat.
- Use steps, grab-handles and anti-slip surfaces when stepping on and off the tractor.
- Detach and store implement in an area where children normally do not play. Secure implement using blocks and supports.

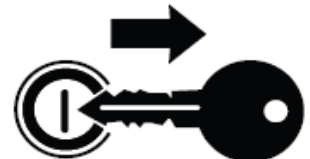

TIRE SAFETY

- Tire changing can be dangerous and must be performed by trained personnel using the correct tools and equipment.
- Always maintain correct tire pressure. Do not inflate tires above recommended pressures shown in the Operator's Manual.
- When inflating tires, use a clip-on chuck and extension hose long enough to allow you to stand to one side and NOT in front of or over the tire assembly. Use a safety cage if available.
- Securely support the implement when changing a wheel.
- When removing and installing wheels, use wheel handling equipment adequate for the weight involved.
- Make sure wheel bolts have been tightened to the specified torque.
- Some attachments may have foam or sealant inside them and must be disposed of properly.



OPERATION SAFETY

- Stay alert for holes, rocks, and roots in the terrain and other hidden hazards. Keep away from drop-offs.
- Stop implement immediately upon striking an obstruction. Turn engine off, remove key, inspect and repair any damage before resuming operation.
- Never operate tractor and implement under trees with low hanging limbs. Operators can be knocked off the tractor and then run over by implement.

TRANSPORT SAFELY

- Comply with federal, state, and local laws.
- Use towing vehicle and trailer of adequate size and capacity. Secure equipment towed on a trailer with tie downs and chains.
- Sudden braking can cause a towed trailer to swerve and upset. Reduce speed if trailer is not equipped with brakes.
- Avoid contact with any overhead utility lines or electrically charged conductors.
- Always drive with load on end of loader arms low to the ground.
- Always drive straight up and down steep inclines with heavy end of a tow vehicle with loader attachment on the "uphill" side.
- Engage park brake when stopped on an incline.
- Maximum transport speed for an attached equipment is 20 mph. DO NOT EXCEED. Never travel at a speed which does not allow adequate control of steering and stopping. Some rough terrains require a slower speed.
- As a guideline, use the following maximum speed weight ratios for attached equipment:
 - 20 mph** when weight of attached equipment is less than or equal to the weight of machine towing the equipment.
 - 10 mph** when weight of attached equipment exceeds weight of machine towing equipment but not more than double the weight.



IMPORTANT: Do not tow a load that is more than double the weight of the vehicle towing the load.



PRACTICE SAFE MAINTENANCE

- Understand procedure before doing work. Refer to the Operator's Manual for additional information.
- Work on a level surface in a clean dry area that is well-lit.
- Lower implement to the ground and follow all shutdown procedures before leaving the operator's seat to perform maintenance.
- Do not work under any hydraulic supported equipment. It can settle, suddenly leak down, or be lowered accidentally. If it is necessary to work under the equipment, securely support it with stands or suitable blocking beforehand.
- Use properly grounded electrical outlets and tools.
- Use correct tools and equipment for the job that are in good condition.
- Allow equipment to cool before working on it.
- Disconnect battery ground cable (-) before servicing or adjusting electrical systems or before welding on implement.
- Inspect all parts. Make certain parts are in good condition & installed properly.
- Replace parts on this implement with genuine ABI Attachments parts only.
- Do not alter this implement in a way which will adversely affect its performance.
- Do not grease or oil implement while it is in operation.
- Remove buildup of grease, oil, or debris.
- Always make sure any material and waste products from the repair and maintenance of the implement are properly collected and disposed.
- Remove all tools and unused parts before operation.



PREPARE FOR EMERGENCIES

- Be prepared if a fire starts.
- Keep a first aid kit and fire extinguisher handy.
- Keep emergency numbers for doctor, ambulance, hospital and fire department near phone.



USE SAFETY LIGHTS AND DEVICES

- Slow moving tractors, skid steers, self-propelled machines, and towed equipment can create a hazard when driven on public roads. They are difficult to see, especially at night. Use the Slow Moving Vehicle sign (SMV) when on public roads.
- Flashing warning lights and turn signals are recommended whenever driving on public roads.



KEEP RIDERS OFF MACHINERY

- Never carry riders on tractor or implement.
- Riders obstruct operator's view and interfere with the control of the tow vehicle.
- Riders can be struck by objects or thrown from the equipment.
- Never use tractor or implement to lift or transport riders.



WEAR PERSONAL PROTECTION EQUIPMENT

- Wear protective clothing and equipment appropriate for the job such as safety shoes, safety glasses, hard hat, and ear plugs.
- Clothing should fit snug without fringes and pull strings to avoid entanglement with moving parts.
- Prolonged exposure to loud noise can cause hearing impairment or hearing loss. Wear suitable hearing protection such as earmuffs or earplugs.
- Operating equipment safely requires the operator's full attention. Avoid wearing headphones while operating equipment.



USE SEAT BELT AND ROPS

- ABI Attachments recommends the use of a CAB or roll-over protective structures (ROPS) and seat belt in almost all tow vehicles. Combination of a CAB or ROPS and seat belt will reduce the risk of serious injury or death if the tow vehicle should be upset.
- If ROPS is in the locked-up position, fasten seat belt snugly and securely to help protect against serious injury or death from falling and machine overturn.



AVOID HIGH PRESSURE FLUIDS HAZARD

- Escaping fluid under pressure can penetrate the skin causing serious injury.
- Before disconnecting hydraulic lines or performing work on the hydraulic system, be sure to release all residual pressure.
- Make sure all hydraulic fluid connections are tight and all hydraulic hoses and lines are in good condition before applying pressure to the system.
- Use a piece of paper or cardboard, NOT BODY PARTS, to check for suspected leaks.
- Wear protective gloves and safety glasses or goggles when working with hydraulic systems.
- DO NOT DELAY. If an accident occurs, see a doctor familiar with this type of injury immediately. Any fluid injected into the skin or eyes must be treated within a few hours or gangrene may result.



AVOID UNDERGROUND UTILITIES

Dig Safe, Call 811 (USA).

- Always contact your local utility companies (electrical, telephone, gas, water, sewer, and others) before digging so that they may mark the location of any underground services in the area.
- Be sure to ask how close you can work to the marks they positioned.





WARNING! NEVER PUMP FLAMMABLE OR EXPLOSIVE FLUIDS SUCH AS GASOLINE, FUEL OIL, KEROSENE, ETC. NEVER PUMP ACIDS (I.E. ACID FERTILIZER). NEVER USE IN EXPLOSIVE ATMOSPHERES. THE PUMP SHOULD BE USED ONLY WITH LIQUIDS COMPATIBLE WITH THE PUMP COMPONENT MATERIALS. REFER TO 'HYPRO PUMP MODEL 1502C' ONLINE OPERATOR'S MANUAL FOR SPECIFICATIONS AND ADDITIONAL INFORMATION BELOW:



<https://www.pentair.com/content/dam/extranet/web/nam/hypro/manuals/l-1572-roller-pumps-iom.pdf>

FAILURE TO FOLLOW THIS WARNING CAN RESULT IN PERSONAL INJURY AND/OR PROPERTY DAMAGE AND WILL VOID THE PRODUCT WARRANTY.

IMMEDIATELY AFTER PUMP SHUTOFF:

Use a pressure relief device on the discharge side of the pump or immediately shut off the power source after use to prevent damage from pressure buildup. When the pump discharge is blocked or otherwise closed while power source is still running, serious injury could occur.

PUMP SAFETY GUIDELINES:

- Never run the pump faster than the maximum recommended speed of 540 RPM.
- Never pump at pressure higher than the maximum recommended pressure.
- Never pump liquids at temperatures higher than the recommended maximum temperatures (140° F/60° C) or temperatures under 32° F (0° C) as this may damage the pump.
- Make certain that the power source conforms to the requirements of your equipment. Refer to your tractor's owner's manual for additional information.
- Provide adequate protection in guarding around the moving parts such as the shaft and pulleys.
- Release all pressure within the system before servicing any component.
- Drain all liquids from the system before servicing any component.
- Check all hoses for weak or worn condition before each use. Make certain that all connections are tight and secure.
- Periodically inspect the pump and the system components. Perform routine maintenance as required by the pump manufacturer's operator's manual.
- Use only pipe, hose and fittings rated for the maximum PSI rating of the pump.
- Never use these pumps for pumping water or other liquids for human or animal consumption.

SEASONAL SHUTDOWN PROCEDURES:

WATER SYSTEM:

- Your unit may be winterized. Failure to properly winterize water tank and pump may result in damage to the water tank and pump components that may not be covered by Manufacturer Warranty. Please contact the ABI Customer Service Department for information

WINTERIZATION GUIDELINES:

- Run RV/Marine antifreeze through the entire watering system, including each spray nozzle.
- Disconnect the water hosing from the pump and drain.
- Store hosing so they are not kinked or laying on the ground.
- Remove the four (4) cap screws that bolt the water pump onto the ABI DragMaster Horizon.
- Drain the water out of the pump and fill the water pump with RV/Marine antifreeze for winterizing while in storage. This will keep the pump from cracking due to frozen water remaining in the pump and reduce oxidation as well as lubricating gaskets and parts during long storage periods.

HANDLING WATER PRODUCTS AND CHEMICALS:

- Waste products, such as used transmission oil, fuel, coolants, etc. can harm the environment and people.
- Do not use beverage containers for waste fluids. Someone may drink from them.
- Contact your local Recycling Center to learn about how to recycle or dispose of waste products. Material Safety Data Sheets (MSDS) provide specific details on the chemicals, physical and health hazards, safety procedures for using the chemical and emergency response techniques.
- The retailer of the chemical products used with your machine is responsible for providing the MSDS for that product.





STAY CLEAR OF ROTATING DRIVELINES:

- Engaging in rotating drivelines can cause serious injury or death.
- DO NOT LEAN OVER or attempt to step-over a rotating driveline while in operation.
- Do not use the driveline as a step when it is in operation or stopped.



SAFETY LABELS

SAFETY DECALS ARE PLACED ON THE ABI DRAGMASTER HORIZON FOR THE PERSONAL SAFETY OF THE OPERATOR, AND ANY PERSONS IN THE VICINITY OF THE EQUIPMENT WHILE IT IS IN OPERATION. BE SURE TO KEEP THE SAFETY DECALS CLEAN AND READABLE. IF THE DECALS EVER BECOME DAMAGED OR ILLEGIBLE, CONTACT ABI CUSTOMER SERVICE AT (877)788-7253 FOR A REPLACEMENT.

	⚠ WARNING 10-10977	
	FALLING BLADE HAZARD	
	<ul style="list-style-type: none"> • Can cause serious injury or death • Keep hands and feet from under raised blades/rakes/teeth unless it is properly blocked and secured. 	<ul style="list-style-type: none"> • Always put implement in lowest possible position when adjusting or repairing • Always store implement in lowered position

		⚠ WARNING 10-10976	
		CRUSHING AND PINCHING HAZARD	
		<ul style="list-style-type: none"> • Be extremely careful handling various parts of the machine. They are extremely heavy and hands, fingers, feet and other body parts could be crushed or pinched between tow vehicle and implement. • Adjust controls from tow vehicle seat only. 	<ul style="list-style-type: none"> • Do not stand between tow vehicle and implement when tow vehicle is in gear. • Make sure parking brake is engaged before going between tow vehicle and implement. • Stand clear of machine when in operation or being raised or lowered.

	⚠ WARNING 10-10978	
	TO PREVENT SERIOUS INJURY OR DEATH:	
<ul style="list-style-type: none"> • Avoid unsafe operation and maintenance. Do not operate or work on this machine without reading and understanding the operator's manual. • If manual is lost, call 877-788-7253 • Do not allow riders and keep others away during operation. 	<ul style="list-style-type: none"> • Lower implement, stop tow vehicle engine, set park brake and remove ignition key before servicing, adjusting, repairing or unplugging. • Safely support and secure implement before adjustments or repairs are made. • Park or block implement so it will not roll when disconnecting from tow vehicle. 	<ul style="list-style-type: none"> • Never place any part of the body underneath implement or between movable parts even when the engine has been turned off. • DO NOT operate or transport at high speeds. • DO NOT operate or transport on steep slopes.

DANGER

PINCH POINT

KEEP HANDS CLEAR

	⚠ CAUTION
	STAND CLEAR WHILE ADJUSTING

⚠ WARNING

DO NOT STEP ON TIRE

PARTS AND CONTROLS

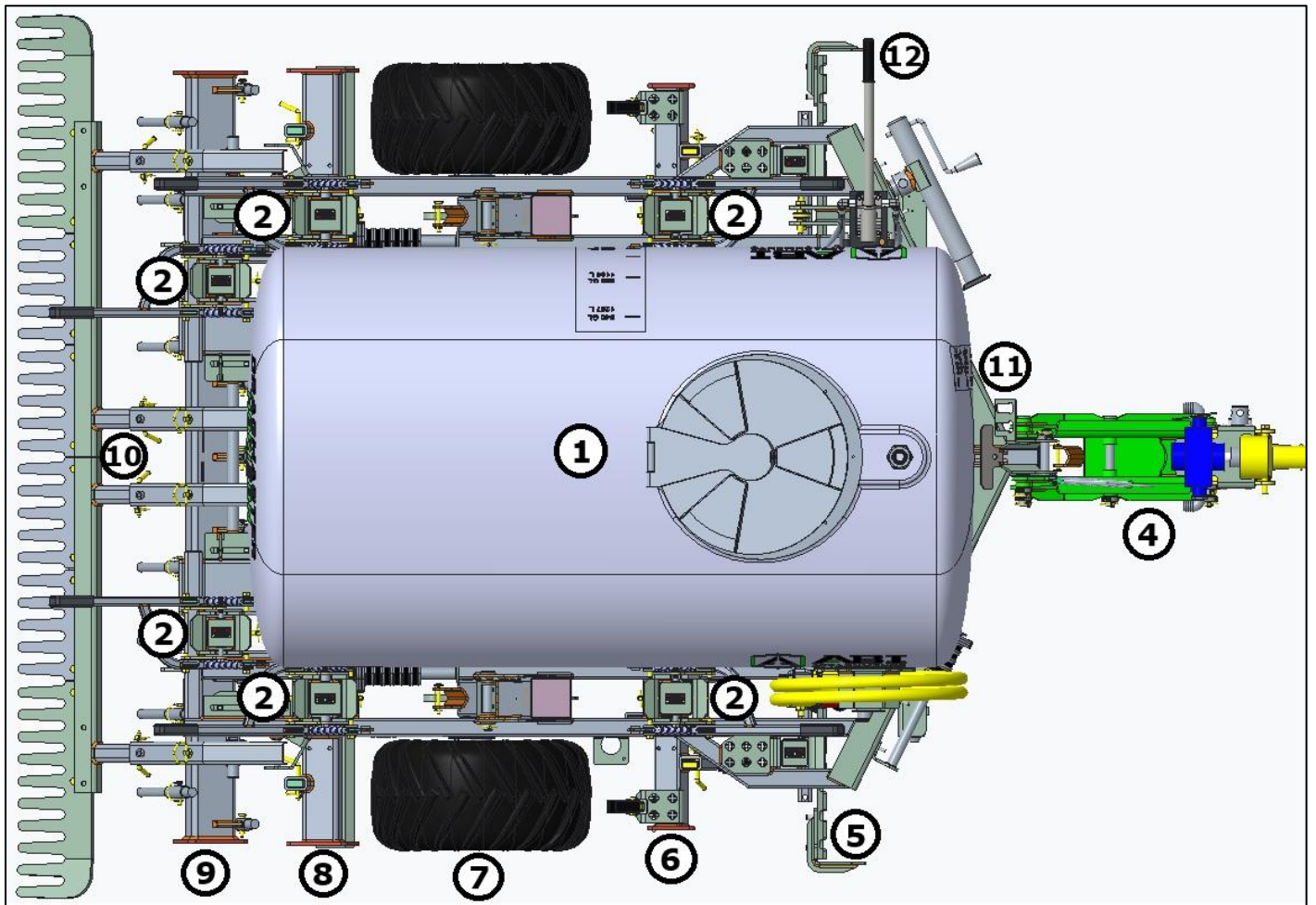

ITEM	DESCRIPTION	ITEM	DESCRIPTION
1	340 GALLON WATER TANK	7	HYDRAULIC WHEEL LIFT
2	RAPID-SET HANDLES (6 TOTAL)	8	RAPID-SET PROFILE BLADES
3	SPRAY HOSE (OPTION, NOT SHOWN)	9	RAPID-SET GROOMING RODS
4	HYDRAULIC TONGUE ASSEMBLY	10	FLOATING FINISH RAKE
5	HYDRAULIC LEVEL BLADE	11	RECIRCULATING WATER VALVE
6	RAPID-SET SCARIFIERS	12	LEVEL BLADE HAND PUMP (OPTION)

FEATURES EXPLAINED

340 GALLON WATER TANK

THE WATERING SYSTEM HAS A PTO DRIVEN PUMP THAT PUTS OUT UP TO 15 GPM THROUGH 2 NOZZLES MOUNTED IN FRONT OF THE LEVELING BLADE. THE OPTIONAL REAR SPRAY ALLOWS THE DRAG TO ACT LIKE A WATER TRAILER, PUTTING AN EVEN AMOUNT OF WATER OUT OF A SINGLE POINT REAR NOZZLE.

RAPID-SET HANDLES

THE RAPID SET HANDLES ENABLE THE OPERATOR MAKE PRECISION 1/4" MEASUREMENT CHANGES. THE RAPID SET HANDLES ARE ALPHABETICALLY AND NUMERICALLY LABELED TO ENSURE COMPONENTS ARE SETUP EVENLY ON EACH SIDE OF THE DRAG.

SPRAY HOSE

IF EQUIPPED, THE DRAGMASTER HORIZON COMES WITH AN OPTIONAL SPRAY HOSE THAT CAN BE CONTROLLED FROM THE SEAT OF THE TRACTOR AS LONG AS THE RECIRCULATION VALVE IS OPEN. THIS ENABLES THE OPERATOR TO SPOT TREAT CERTAIN AREAS OF THE ARENA.

HYDRAULIC TONGUE

ASSEMBLY

THE DRAGMASTER HORIZON COMES WITH A HITCH THAT ALLOWS THE DRAG TO FEATHER OFF THE MATERIAL WITH THE RAKE AS IT EXITS THE ARENA. THE HYDRAULIC TONGUE CYLINDER IS DESIGNED TO ALLOW FOR EASY LEVELING OF THE FRAME. ONCE THE HYDRAULIC TONGUE CYLINDER IS SET, NO FURTHER CHANGES WILL BE NEEDED TO USE WITH YOUR TRACTOR. SHOULD YOU NEED TO SWITCH TRACTORS, THE HYDRAULIC TONGUE CYLINDER COMES WITH MULTIPLE SET COLLARS AND A

FINE TUNE NUT TO MAKE LEVELING FRAME A SIMPLE PROCESS. SIMPLY REPLACE THE SET COLLAR WITH AN APPROPRIATE SIZE AND ADJUST THE FINE TUNE NUT AS NEEDED TO LEVEL YOUR DRAGMASTER HORIZON.

HYDRAULIC LEVEL BLADE

THE LEVELING BLADE COMBS MATERIAL TO CUT DOWN HIGH SPOTS AND FILL IN LOW ONES. IT IS DESIGNED TO ALWAYS BE PARTIALLY ENGAGED WITH THE ARENA FOOTING. THE LEVELING BLADE IS EITHER HYDRAULICALLY CONTROLLED FROM THE SEAT OF THE TRACTOR, OR BY A MANUAL PUMP. THIS BLADE OPERATES INDEPENDENTLY FROM THE FRAME USING "LEVEL-LOCK" TECHNOLOGY WHICH LIMITS DOWNWARD TRAVEL FOR A REPEATABLE SETTING USING THE INCLUDED STOP COLLARS.

IF EQUIPPED WITH THE "TRACTOR CONTROL" OPTION, THE NEEDLE VALVE ON THE END OF THE HYDRAULIC HOSES CONNECTING TO THE TRACTOR CAN BE USED TO CONTROL THE SPEED OF ADJUSTMENT. SPIN THE KNOB CLOCKWISE TO SLOW DOWN, OR COUNTERCLOCKWISE TO INCREASE THE LEVEL BLADE'S SPEED.

RAPID-SET SCARIFIERS

THE "RAPID-SET" SCARIFIERS ARE FOR DECOMPACTING HARD AREAS TO RECOVER COMPACTED FOOTING. THE RAPID-SET HANDLE ALLOWS YOU TO GRADUALLY INCREASE THE DEPTH OF THE SCARIFIERS AS THEY WEAR IN QUARTER-INCH INCREMENTS. INCLUDED WITH THE DRAGMASTER HORIZON ARE TWO (2) EXTRA SCARIFIERS. THESE CAN BE USED IN THE REAR SCARIFIER POCKETS IF YOU SEE COMPACTION FROM YOUR TRACTOR

TIRES THAT ARE NOT BEING ADDRESSED BY THE EXISTING ROW OF SCARIFIERS.

HYDRAULIC WHEEL LIFT

FOUR FLOTATION TIRES SUPPORT THE WEIGHT OF THE DRAGMASTER HORIZON, KEEPING DEPTH CONSISTENT WITH EVERY PASS. THESE WHEELS ALSO ACT IN CONJUNCTION WITH THE REAR TIRES OF THE TRACTOR TO MAKE A "GROUND PLANE" WHICH ALLOWS THE DRAG TO EASILY RIP, GRADE, AND LEVEL AN ARENA.

RAPID-SET PROFILE BLADES

THE PATENTED PROFILE BLADES WILL LOOSEN 100% OF THE ARENA FOOTING WITH EVERY PASS. THIS ELIMINATES ALL RIDGES IN THE FOOTING AND ALLOWS THE OPERATOR TO CREATE A "FALSE BASE" IN THE FOOTING.

RAPID-SET GROOMING RODS

THE ABI DRAGMASTER HORIZON USES TWO ROWS OF OFFSET GROOMING RODS, 1" IN DIAMETER AND 6" IN LENGTH, FOR LOOSENING AND DECOMPACTING THE ARENA FOOTING. THE OFFSET ROWS ALLOW THE OPERATOR TO ACHIEVE MAXIMUM LOOSENING COVERAGE AND ELIMINATE ALL SHNAK LINES AND VARIATION.

FLOATING FINISH RAKE

THE FLOATING FINISH RAKES PRESS AIR OUT OF THE FOOTING, WHILE "FLOATING" OVER ANY UNDULATIONS, LEAVING THE SURFACE LEVEL AND SMOOTH. BY ADJUSTING THE LENGTH, AND THEREFORE THE ANGLE OF THE FINISH RAKE, THE OPERATOR CAN CHANGE THE FIRNESS OF THE FOOTING.

RECIRCULATING WATER VALVE

THE "RECIRC" VALVE IS LOCATED ON THE FRONT LEFT OF THE DRAG FRAME. THIS ALLOWS THE OPERATOR TO FINE TUNE THE AMOUNT OF WATER PUT OUT BY THE SPRAYER NOZZLES, WHILE ALSO PREVENTING DAMAGE TO THE PTO PUMP BY A CLOGGED NOZZLE. THIS VALVE SHOULD ALWAYS BE OPENED SLIGHTLY WHEN OPERATING TO PREVENT DAMAGE TO THE PTO PUMP.

LEVEL BLADE HAND PUMP

IF EQUIPPED, THIS HAND PUMP DRIVES THE LEVEL BLADE CYLINDER UP OR DOWN AND ALLOWS FOR 1/8" CHANGES IN THE LEVEL BLADE HEIGHT WITHOUT A SECOND HYDRAULIC REMOTE ON THE TRACTOR. MOTION CAN BE CHANGED FROM UP OR DOWN BY ROTATING THE SMALL HANDLE ON THE BODY OF THE PUMP.

UNLOADING YOUR EQUIPMENT

IMPORTANT: PLEASE INSPECT AND NOTE ANY DAMAGE TO THE SHIPMENT BEFORE ACCEPTING AND SIGNING FOR THE SHIPMENT. IF THERE IS ANY DOUBT OR QUESTION PLEASE NOTE IT ON THE PAPERWORK. DAMAGE CLAIMS DUE TO SHIPPING WILL BE SLOWED DOWN AND MORE DIFFICULT TO PROCESS WITHOUT THIS STEP.

THE ABI DRAGMASTER HORIZON SHIPS ONLY VIA FLATBED TRUCK. IF REQUIRED, ADDITIONAL OPTIONS, ACCESSORIES, AND PARTS NEEDED TO COMPLETE THE DRAG MAY BE CONTAINED IN A SEPARATE CRATE. PLEASE MAKE SURE ALL ITEMS ARE UNLOADED AND PLEASE CHECK LOAD FOR SHIPPING DAMAGE BEFORE SIGNING FOR THE DELIVERY.

USE **ONLY** THE LABELED FORK POCKETS IN THE **REAR** OR **SIDE** OF THE FRAME TO REMOVE THE DRAG FROM THE DELIVERY TRUCK.

A FORKLIFT WITH NO LESS THAN A MAXIMUM RATED LOAD CAPACITY OF 5,000 LBS IS REQUIRED TO OFFLOAD THE DRAG FROM THE DELIVERY TRUCK.

IT IS THE CUSTOMER'S RESPONSIBILITY TO HAVE A PROPERLY RATED FORKLIFT AND AN EXPERIENCED FORKLIFT OPERATOR ON-SITE WHEN THE DELIVERY TRUCK ARRIVES. PLEASE REFER TO THE SPECIFICATION SHEET ON PAGE 32 FOR THE SHIPPING WEIGHT AND DIMENSIONS.

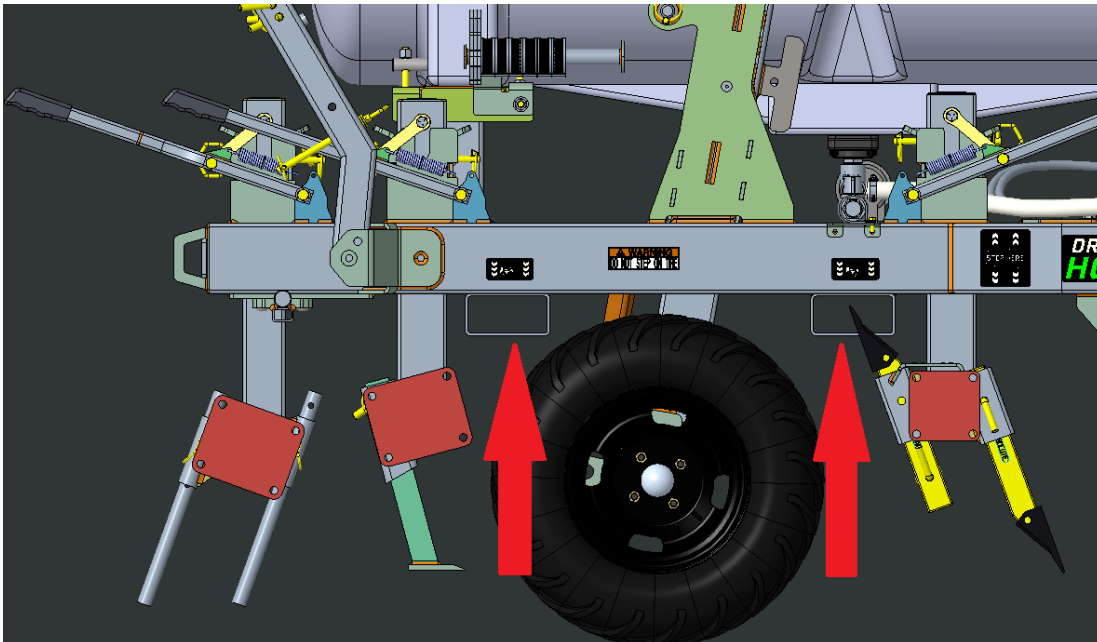

10FT INITIAL ASSEMBLY

EXPLODED VIEWS OF THE EXTENSIONS ARE AVAILABLE AT THE END OF THE MANUAL
LEVEL BLADE

ASSEMBLE THE LEVEL BLADE EXTENSIONS USING THE INCLUDED 5/8" HARDWARE, ACCORDING TO THE ATTACHED DIAGRAM. THE LEFT AND RIGHT SIDES ARE IDENTICAL. THE GREY SPACERS GO BETWEEN THE BLADE SECTION AND THE EXTENSION BRACKET. YOU WILL HAVE TO REMOVE AND REINSTALL THE OUTERMOST BOLT ON THE EXISTING LEVEL BLADE SECTION. MOUNT THE EXTENSIONS, THEN INSTALL THE LEVEL BLADE SECTIONS. AN EXAMPLE OF THE ASSEMBLED LEVEL BLADE EXTENSION IS SHOWN BELOW.

THIS USES A 15/16" WRENCH.

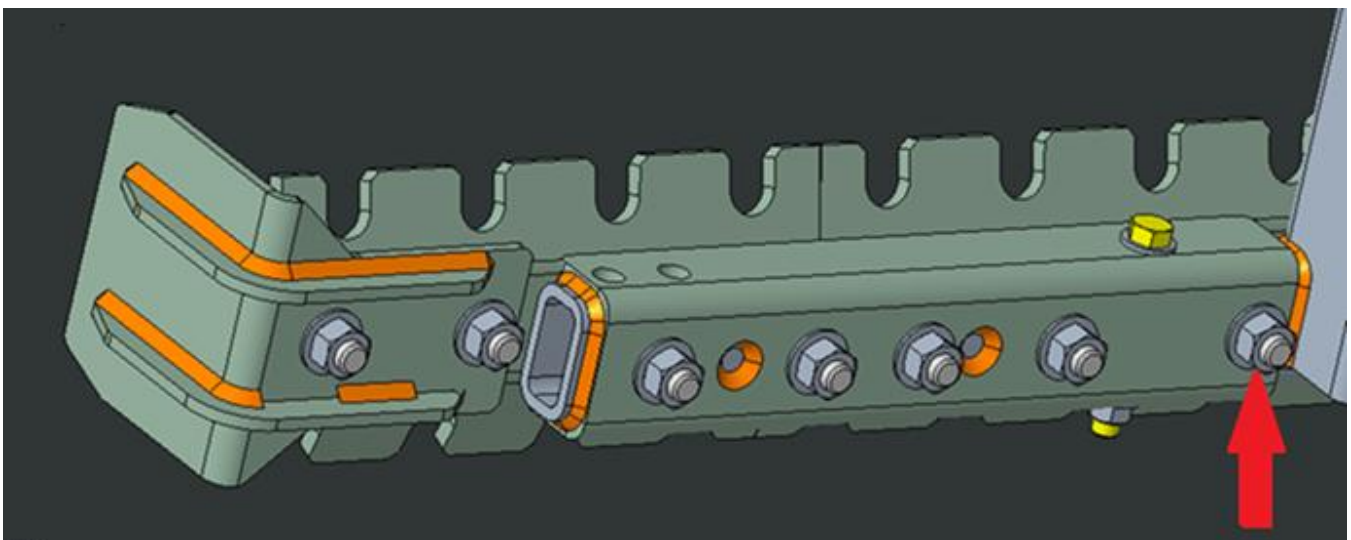
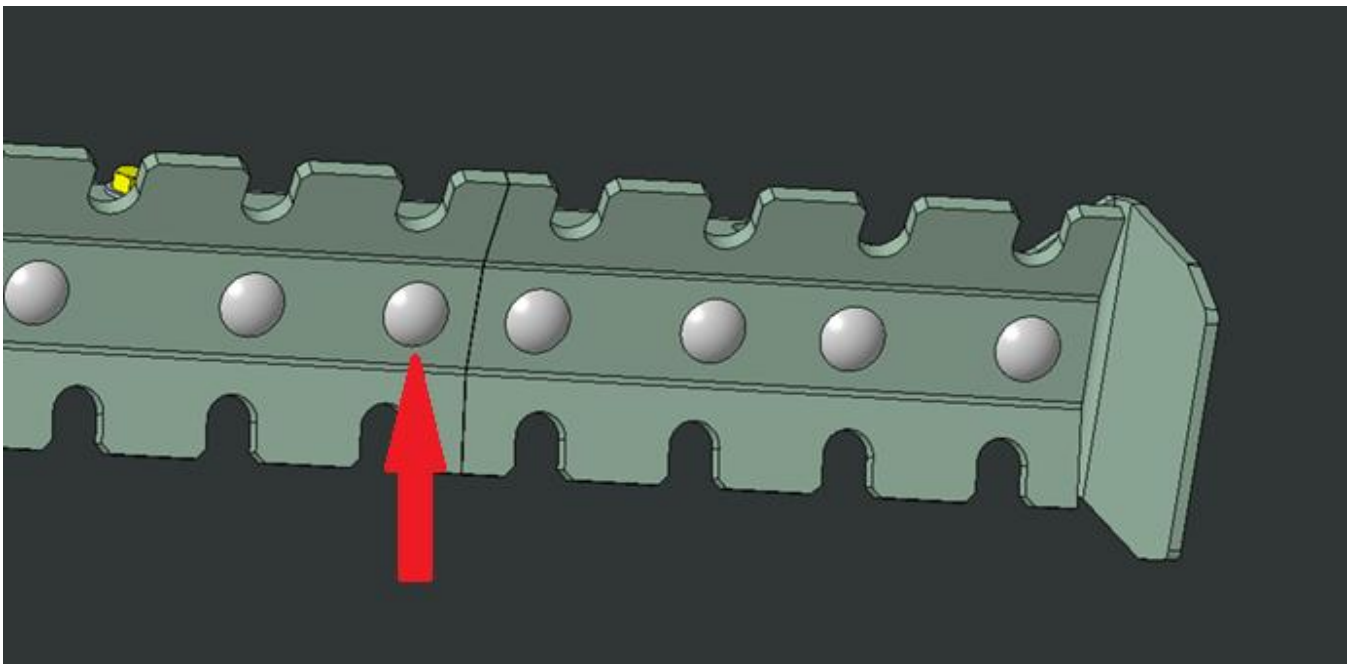

SCARIFIERS

ASSEMBLE THE SCARIFIER EXTENSIONS USING THE INCLUDED 1/2" HARDWARE, ACCORDING TO THE ATTACHED DIAGRAM. THE LEFT AND RIGHT SIDES ARE UNIQUE AND HAVE THREE (3) RECTANGULAR POCKETS EACH. MOUNT THE EXTENSIONS, THEN INSTALL THE SCARIFIERS. AN EXAMPLE OF THE ASSEMBLED SCARIFIER EXTENSION IS SHOWN BELOW.

THIS USES A 3/4" WRENCH.

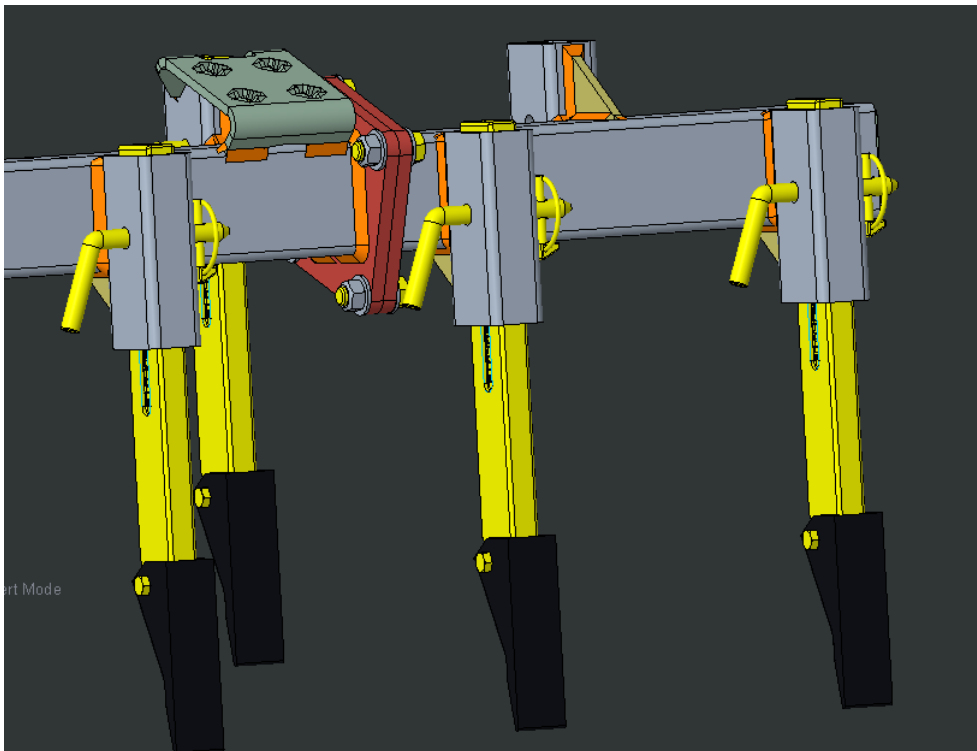
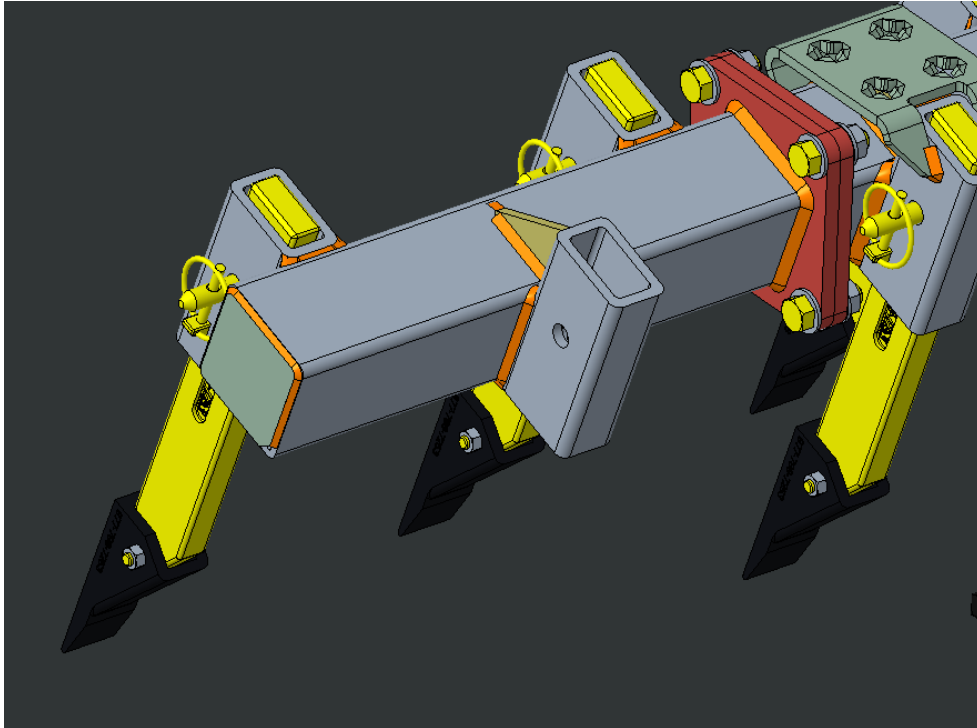

PROFILE BLADES

ASSEMBLE THE PROFILE BLADE EXTENSIONS USING THE INCLUDED 1/2" HARDWARE, ACCORDING TO THE ATTACHED DIAGRAM. THE LEFT AND RIGHT SIDES ARE UNIQUE AND EACH HAVE ONE (1) RECTANGULAR POCKET. MOUNT THE EXTENSIONS, THEN INSTALL THE PROFILE BLADES. AN EXAMPLE OF THE ASSEMBLED PROFILE BLADE EXTENSION IS SHOWN BELOW.

THIS USES A 3/4" WRENCH.

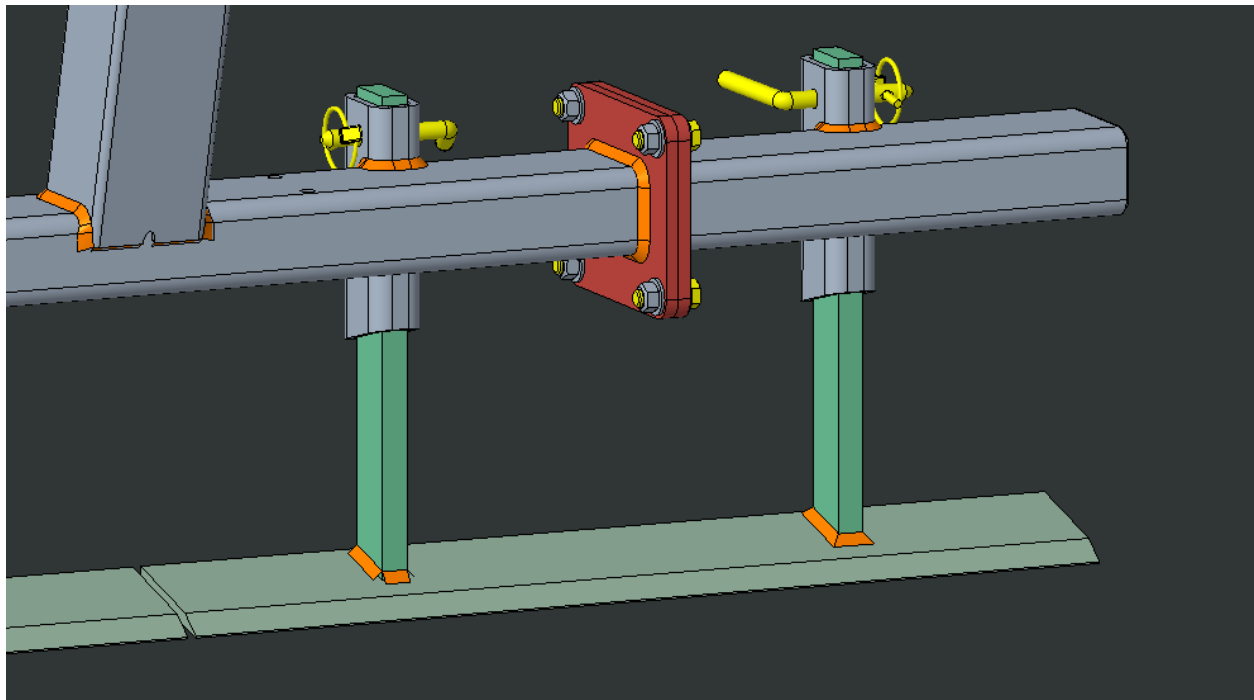
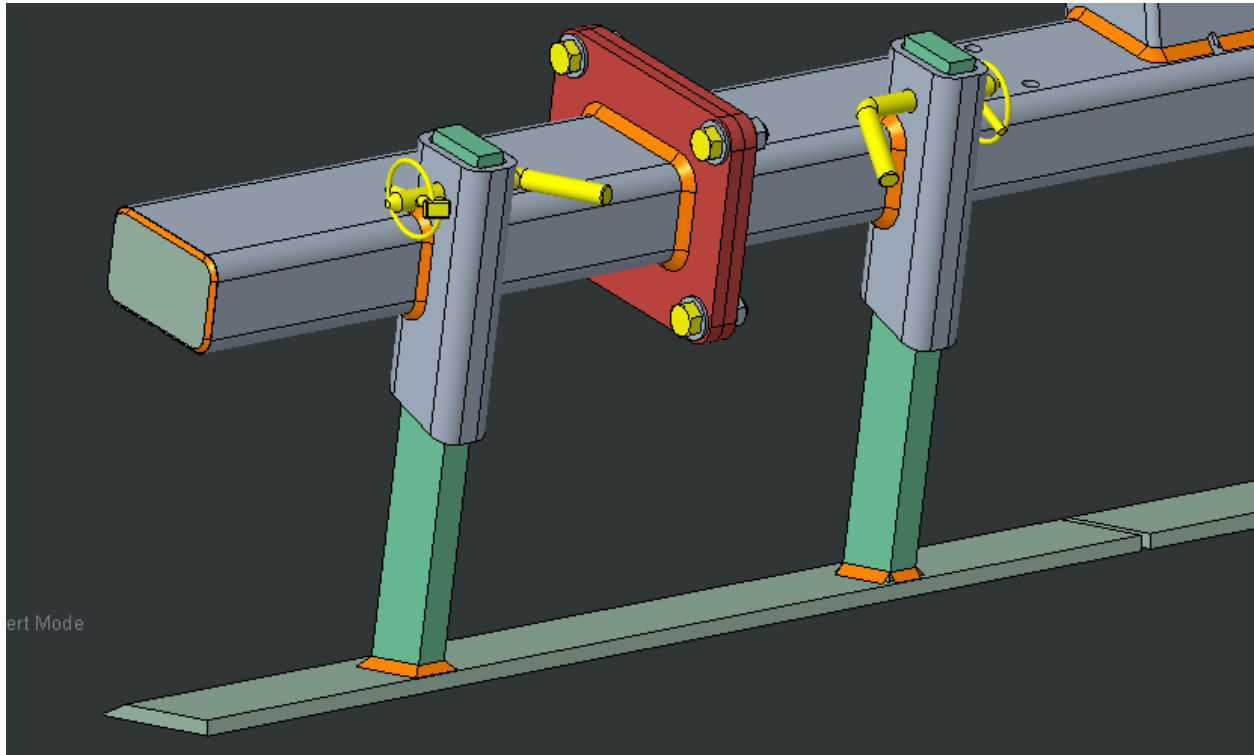

GROOMING RODS

ASSEMBLE THE GROOMING ROD EXTENSIONS USING THE INCLUDED 1/2" HARDWARE, ACCORDING TO THE ATTACHED DIAGRAM. THE LEFT AND RIGHT SIDES ARE UNIQUE AND EACH HAVE THREE (3) ROUND POCKETS. MOUNT THE EXTENSIONS, THEN INSTALL THE GROOMING RODS. AN EXAMPLE OF THE ASSEMBLED GROOMING ROD EXTENSION IS SHOWN BELOW.

THIS USES A 3/4" WRENCH.

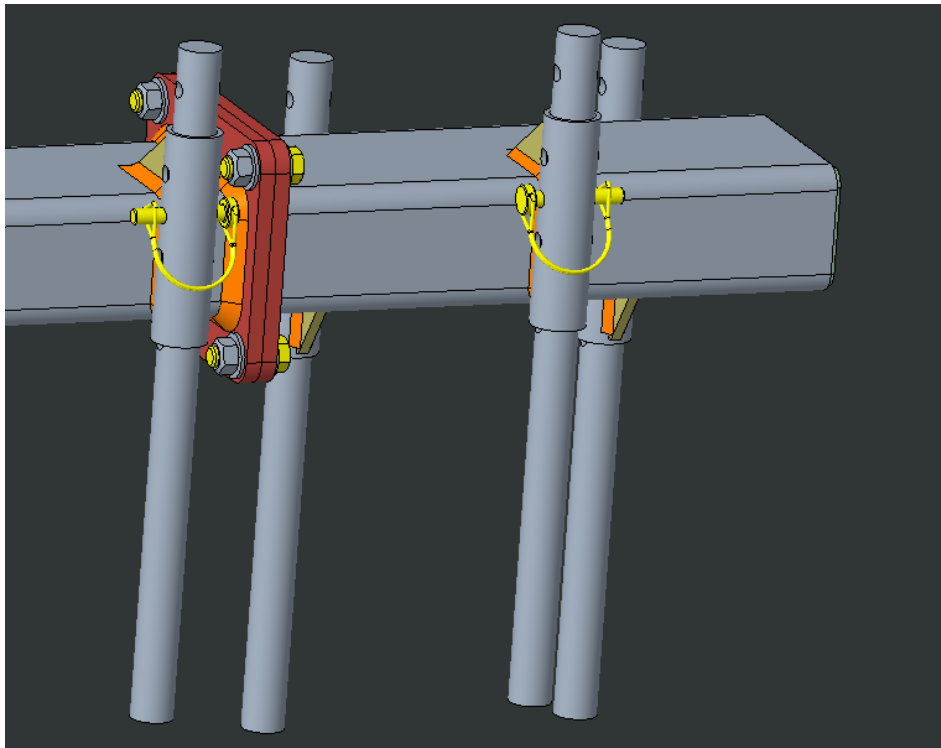
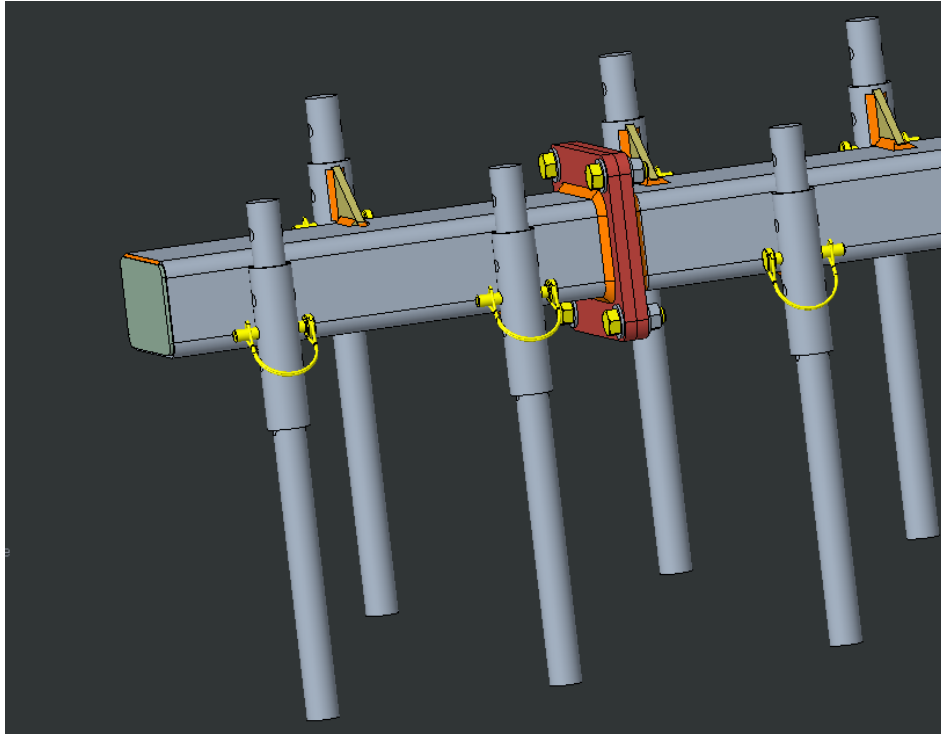

RAKE

ASSEMBLE THE RAKE EXTENSIONS USING THE INCLUDED 1/2" HARDWARE, ACCORDING TO THE ATTACHED DIAGRAM. THE LEFT AND RIGHT SIDES ARE UNIQUE. YOU WILL HAVE TO REMOVE AND REINSTALL THE OUTERMOST BOLT ON THE EXISTING RAKE SECTION. MOUNT THE EXTENSIONS, THEN INSTALL THE RAKE SECTIONS. AN EXAMPLE OF THE ASSEMBLED RAKE EXTENSION IS SHOWN BELOW.

THIS USES A 3/4" WRENCH.

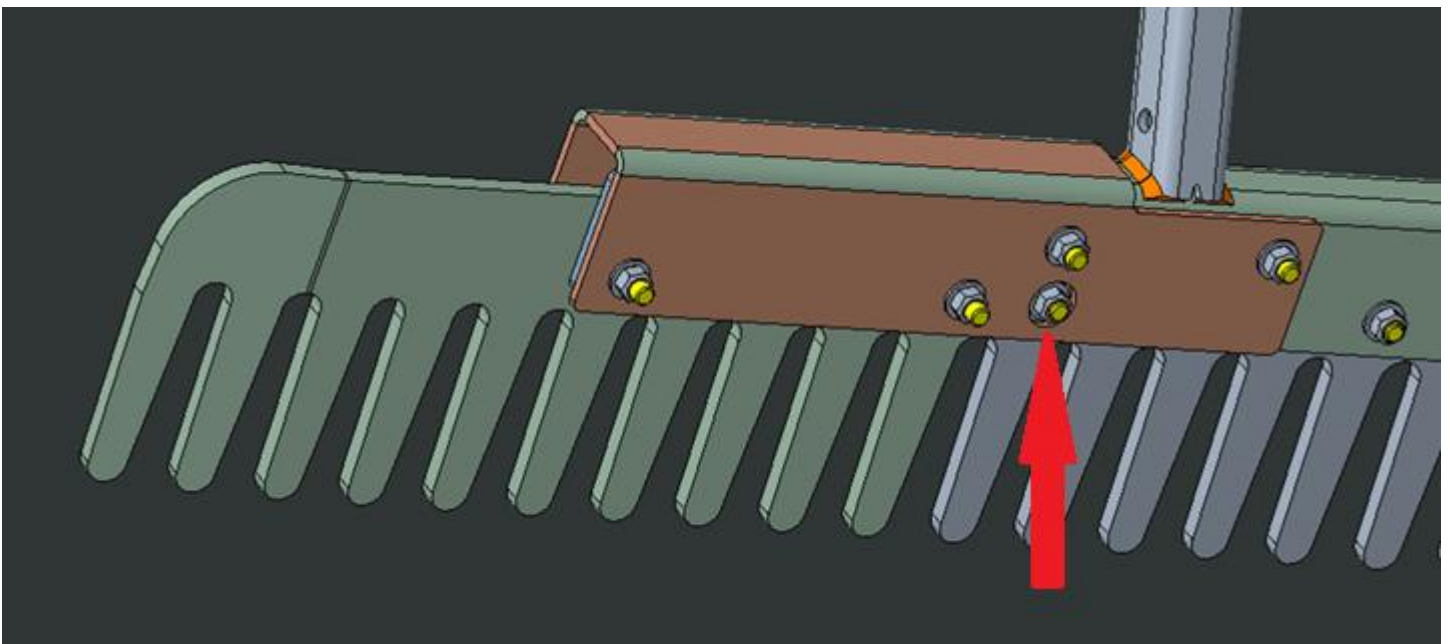
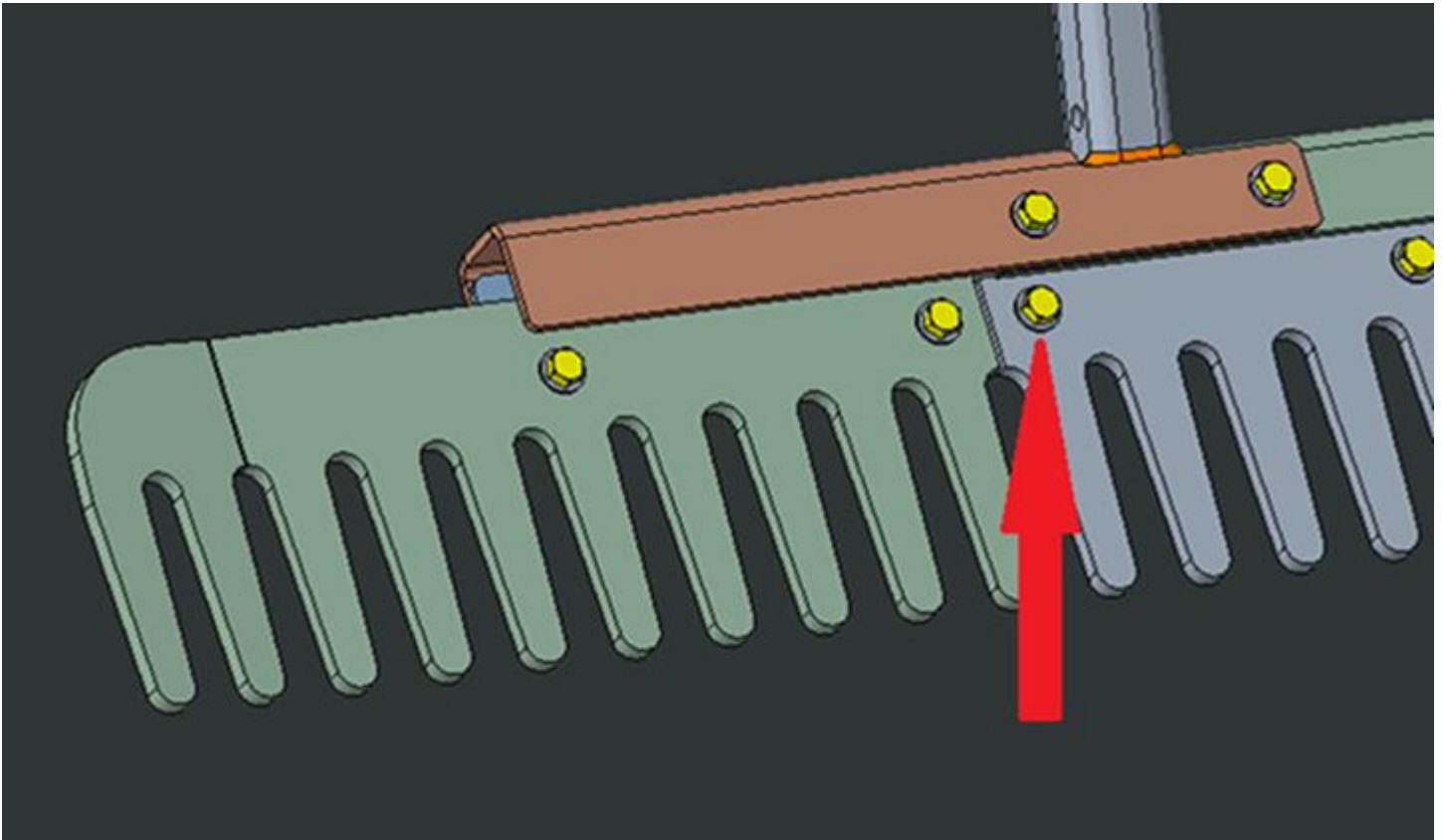

RAIL BLADE INITIAL ASSEMBLY

EXPLODED VIEWS OF THE RAIL BLADE ARE AVAILABLE AT THE END OF THE MANUAL.

ASSEMBLE THE RAIL BLADE USING THE INCLUDED 1/2" HARDWARE. INSERT THE TWO (2) 1/2" BOLTS, WITH WASHERS, FROM THE BOTTOM, THROUGH BOTH SIDES OF THE OUTSIDE EDGE OF THE LEVEL BLADE FRAME ON THE RIGHT SIDE OF THE DRAG.

IF YOU HAVE A 10FT DRAG, THE HOLES ARE LOCATED ON THE OUTSIDE OF THE EXTENSION, IN THE SAME ORIENTATION SHOWN BELOW.

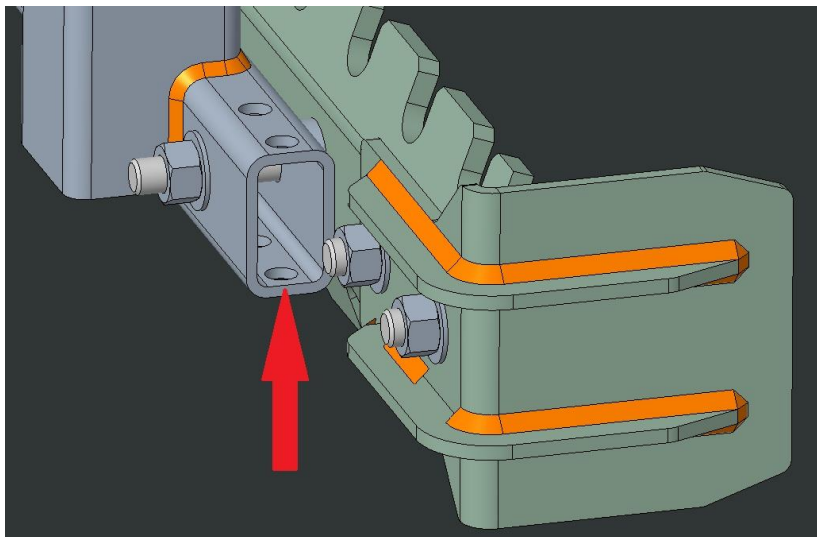

ALIGN THE RAIL BLADE MOUNTING BRACKET AND SLIDE IT OVER THE THREADED ENDS OF THE BOLT AND SET IT ON THE LEVEL BLADE FRAME. ADD THE 1/2" WASHERS AND NUTS TO THE TOPS OF THE BOLTS. TIGHTEN WITH A BOX WRENCH ON TOP AND A RATCHETING WRENCH OR IMPACT ON THE BOTTOM. ADD THE WING BOLT TO THE NUT ON THE TOP OF THE BRACKET. NOTE THE ORIENTATION OF THE BRACKET BELOW.

THIS USES A 3/4" WRENCH.

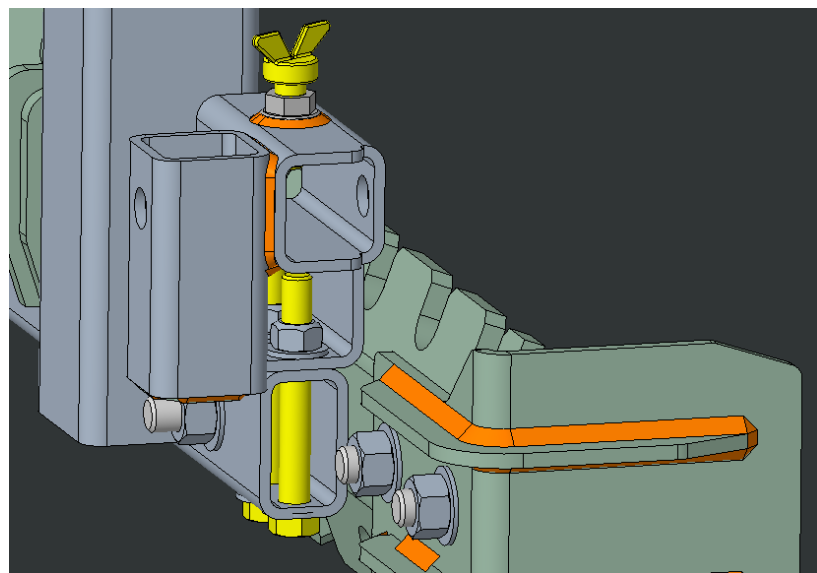

NEXT, ASSEMBLE THE RAIL BLADE. USE THE INCLUDED 1/2" AND 5/16" HARDWARE TO ATTACH THE BLADE TO THE RAIL BLADE ARM. NOTE THE ORIENTATION BELOW. USE THE RESPECTIVE WASHERS ON THE TOP AND BOTTOM OF THE BOLT. TIGHTEN BOTH.

ASSEMBLE THE WALL WHEEL USING THE INCLUDED 5/16" HARDWARE. SLIDE THE WASHER OVER THE BOLT, THEN THE WHEEL. INSERT THIS STACKUP THROUGH THE OUTERMOST HOLE ON THE BLADE AND ADD A WASHER AND NUT ON THE BOTTOM SIDE. TIGHTEN UNTIL THE WHEEL IS SNUG BUT CAN STILL SPIN FREELY.

THIS USES A 3/4" AND A 1/2" WRENCH, RESPECTIVELY.

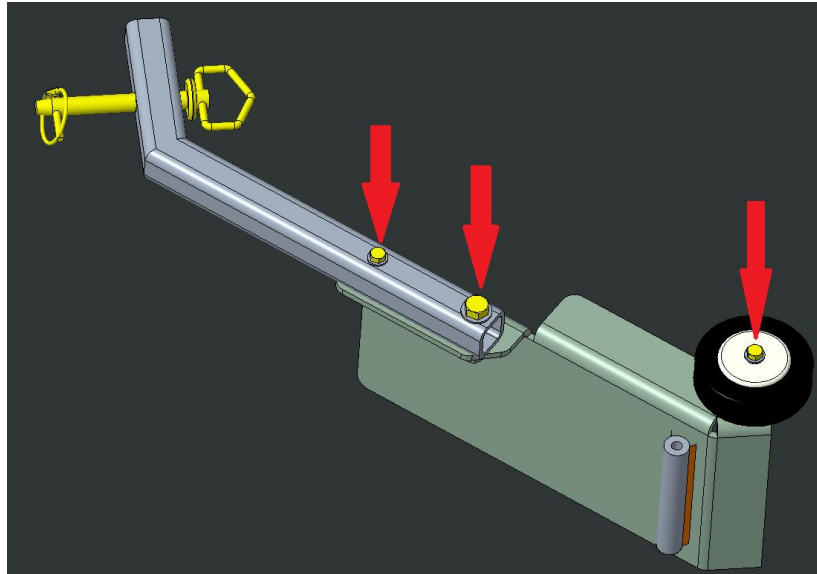

ONCE THE BLADE IS ASSEMBLED, SLIDE IT INTO THE HORIZONTAL TUBE ON THE RAIL BLADE MOUNT, AND PIN IN PLACE WITH THE INCLUDED PIN BY PASSING IT THROUGH THE FOUR (4) WALLS OF THE MOUNT AS SHOWN. USE THE WING BOLT TO TIGHTEN THE BLADE IN PLACE. THIS IS **OPERATING POSITION**. TO PLACE THE RAIL BLADE INTO THE **STORAGE POSITION**, LOOSEN THE WING BOLT AND REMOVE THE PIN, AND SLIDE THE RAIL BLADE OUT. THEN SLIDE THE RAIL BLADE INTO THE VERTICAL TUBE AND REPLACE THE PIN IN THE SAME SET OF HOLES.

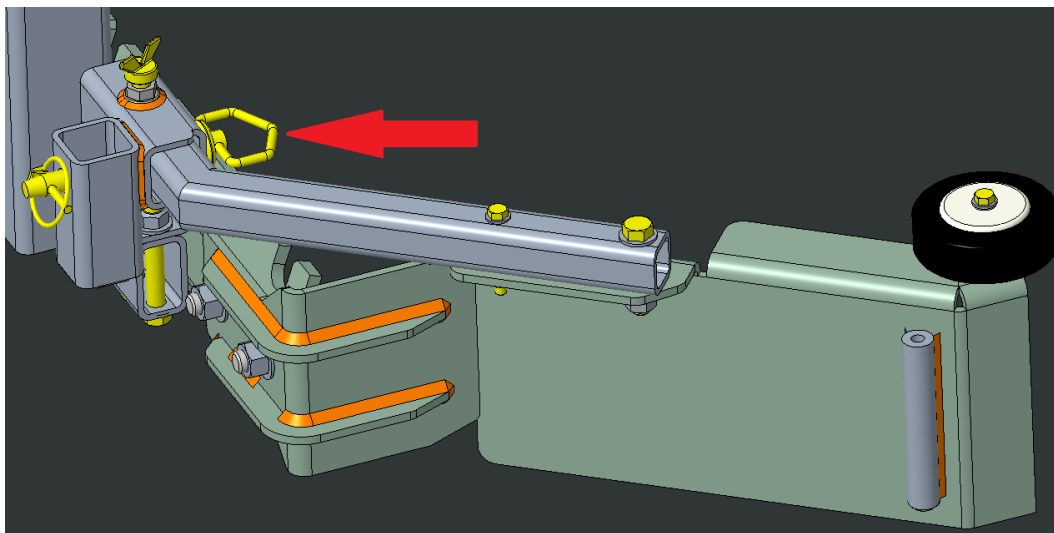

FIRST USE - CONNECTIONS

IF EQUIPPED WITH A 10FT DRAGMASTER HORIZON, COMPLETE INITIAL ASSEMBLY INSTRUCTIONS IN PREVIOUS SECTION BEFORE CONTINUING.

CUTTING PTO SHAFT TO LENGTH

THE PTO DRIVELINE MINIMUM AND MAXIMUM LENGTHS MUST BE CHECKED PRIOR TO INITIAL USE OR WHEN USING A **DIFFERENT TRACTOR** TO ENSURE THE DRIVELINE IS COMPATIBLE WITH ALL WORK CONDITIONS REQUIRED BY THE DRAGMASTER HORIZON. WHEN FULLY EXTENDED THE DRIVELINE MUST HAVE A MINIMUM OVERLAP OF THE INNER AND OUTER SHAFTS BY NOT LESS THAN 1/3 OF THE FREE LENGTH WITH BOTH INNER AND OUTER SHAFTS BEING OF EQUAL LENGTH, OR NOT LESS THAN A 6" OVERLAP.

IT IS VERY IMPORTANT NOT TO OPERATE YOUR DRIVELINE WITH LESS THAN 1/3 FREE LENGTH OR 6" OF OVERLAP AS THIS MAY CAUSE YOUR DRIVELINE TO DETACH WHILE IN OPERATION AND POSE A SAFETY HAZARD TO THE OPERATOR AND POSSIBLE DAMAGE TO THE TRACTOR.

IMPORTANT: ADJUSTING THE PTO DRIVELINE REQUIRES THAT ALL CUTS BE MADE EQUALLY TO THE INNER/OUTER GUARDS AND THE INNER/OUTER SHAFTS.

CONNECTING PTO SHAFT

BEFORE HITCHING THE DRAG TO THE TRACTOR, ATTACH THE PTO SHAFT TO THE DRAG. FIRST PUT THE KEYWAY INTO THE KEYWAY CUTOUT OF THE WATER PUMP INPUT SHAFT. THEN SLIDE THE PTO YOKE OVER THE WATER PUMP INPUT SHAFT, LINING UP THE KEYWAY WITH THE KEYWAY CUTOUT. ENSURE THE KEYWAY AND WATER PUMP INPUT SHAFT ARE FLUSH WITH THE INSIDE SURFACE OF THE YOKE. **YOU MUST INSTALL THE KEYWAY.** THEN, USE A 1/8" ALLEN KEY TO TIGHTEN THE SET SCREW ONTO THE WATER PUMP INPUT SHAFT, THEN TIGHTEN THE SET SCREW NUT WITH AN ADJUSTABLE WRENCH. THE PTO SHAFT SHOULD STAY WITH THE DRAG WHEN NOT IN USE.

TO CONNECT THE PTO SHAFT TO THE TRACTOR, ALIGN THE PTO SHAFT YOKE WITH THE TRACTOR PTO SHAFT, LINING UP THE SPLINES OF THE TWO. THE PTO SHAFT IS A PUSH PIN DESIGN. PRESS THE PUSH PIN AS YOU SLIDE THE PTO SHAFT YOKE OVER THE TRACTOR PTO SHAFT AND RELEASE. **ENSURE THE PUSH PIN ENGAGES** WITH THE PTO SHAFT RELIEF. LIGHTLY PULL ON THE PTO SHAFT TO ENSURE IT IS LOCKED ON.

TO REMOVE, PRESS THE PUSH PIN ON THE PTO SHAFT AND PULL BACKWARDS UNTIL IT COMES OFF THE TRACTOR PTO SHAFT.

CONNECTING DRAG TO TRACTOR

BACK YOUR TRACTOR UP TO THE DRAG, LINING UP THE TRACTOR DRAWBAR AND THE DRAG CLEVIS HITCH. USE THE TONGUE JACK TO ADJUST HEIGHT SO THE DRAWBAR SITS BETWEEN THE CLEVIS HITCH EARS. INSTALL THE INCLUDED 3/4" HITCH PIN INTO THE HOLES IN THE CLEVIS AND THE DRAWBAR.

ENSURE THE **TRACTOR DRAWBAR IS SLID TO IT'S REARMOST POSITION** ON THE TRACTOR, IF APPLICABLE.

CONNECTING HYDRAULIC SYSTEM

LOCATE THE HYDRAULIC REMOTES ON THE REAR OF YOUR TRACTOR. THE HOSES MARKED WITH GREEN HOSE WRAP ARE A PAIR, AND THE HOSES MARKED WITH BLACK HOSE WRAP, IF APPLICABLE, ARE ANOTHER PAIR. THE LONGER HOSE WRAP INDICATES THE CYLINDER EXTENSION LINE, WHILE THE SHORTER HOSE WRAP INDICATES THE CYLINDER RETRACT LINE. INSTALL THE TWO (2) OR FOUR (4) HOSES INTO YOUR TRACTOR REMOTES, NOTING THEIR POSITION FOR FUTURE HOOKUPS. VERIFY YOUR HYDRAULIC CONTROLS OPERATE THE DRAG, AND LEVEL BLADE IF APPLICABLE, IN THE CORRECT DIRECTION. IF THE CYLINDERS MOVE IN THE OPPOSITE DIRECTION AS DESIRED, SWAP THE PAIRS OF HOSE TO THE OPPOSITE CONNECTION.

ENSURE THE HOSES ARE FULLY CONNECTED TO THE TRACTOR REMOTES BEFORE OPERATING.

ENSURE THE HYDRAULIC HOSES DO NOT TOUCH THE PTO SHAFT.

WHEN DISCONNECTING THE DRAG FROM THE TRACTOR, REMOVE THE HYDRAULIC HOSES AND PLACE IN THE HYDRAULIC HOSE HOLDER LOCATED NEXT TO THE FRONT LIFT CYLINDER ON THE DRAG FOR SAFE KEEPING.

TOP-OFF TRACTOR HYDRAULIC RESERVOIR AFTER CONNECTING AND FULLY CYCLING THE HYDRAULIC SYSTEM ON YOUR DRAG.

FIRST USE - ADJUSTMENTS

ADJUSTING HITCH HEIGHT

DEPENDING ON THE HEIGHT OF THE DRAWBAR OF YOUR TRACTOR, YOU MAY NEED TO ADJUST THE FRONT CLEVIS HITCH. WHEN SITTING ALL THE WAY DOWN ON THE SAFETY STOPS, YOUR DRAG SHOULD BE CLOSE TO LEVEL. IF IT IS SIGNIFICANTLY NOSE-UP OR NOSE-DOWN, THE FRONT CLEVIS HITCH CAN BE ADJUSTED TO ACCOUNT FOR THIS.

SUPPORT THE DRAG ON THE TONGUE JACK AND REMOVE THE TWO (2) 5/8" BOLTS. BE SURE TO CATCH THE SPACERS ON THE BOLTS LOCATED INSIDE THE HITCH FRAME. MOVE THE CLEVIS HITCH UP OR DOWN TO SUIT YOUR TRACTOR DRAWBAR HEIGHT AND REINSTALL BOLTS WITH ONE (1) SPACER ON EACH SIDE OF THE CLEVIS PER BOLT.

THIS USES A 15/16" WRENCH.

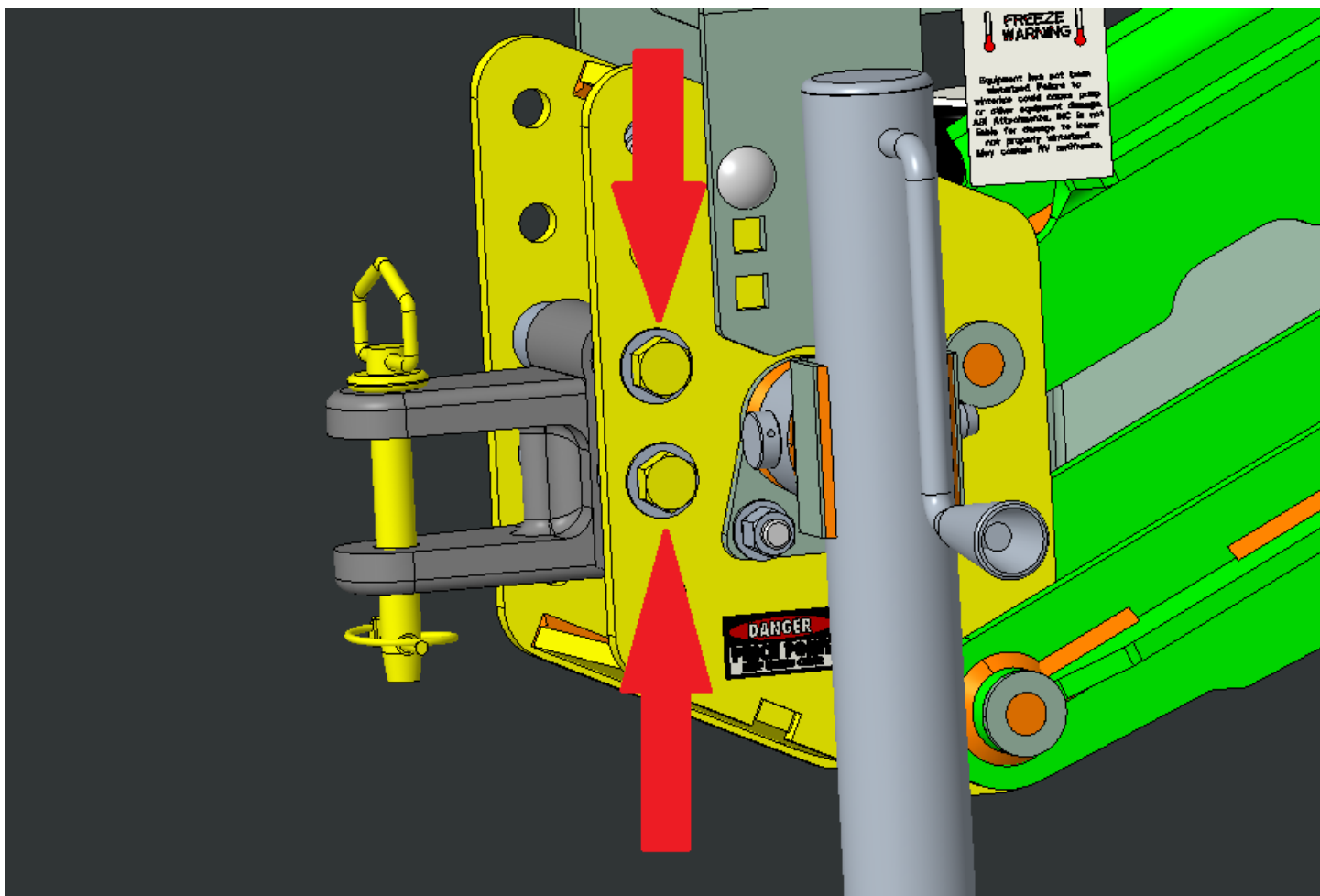

ADJUSTING WATER PUMP

THE WATER PUMP MOUNT HAS HEIGHT ADJUSTMENT. AFTER INITIALLY HITCHING THE DRAG TO THE TRACTOR AND INSTALLING TO PTO SHAFT, ENSURE THE PTO SHAFT SITS LEVEL. ADJUST THE WATER PUMP MOUNT IF NECESSARY.

THIS USES A 3/4" WRENCH.

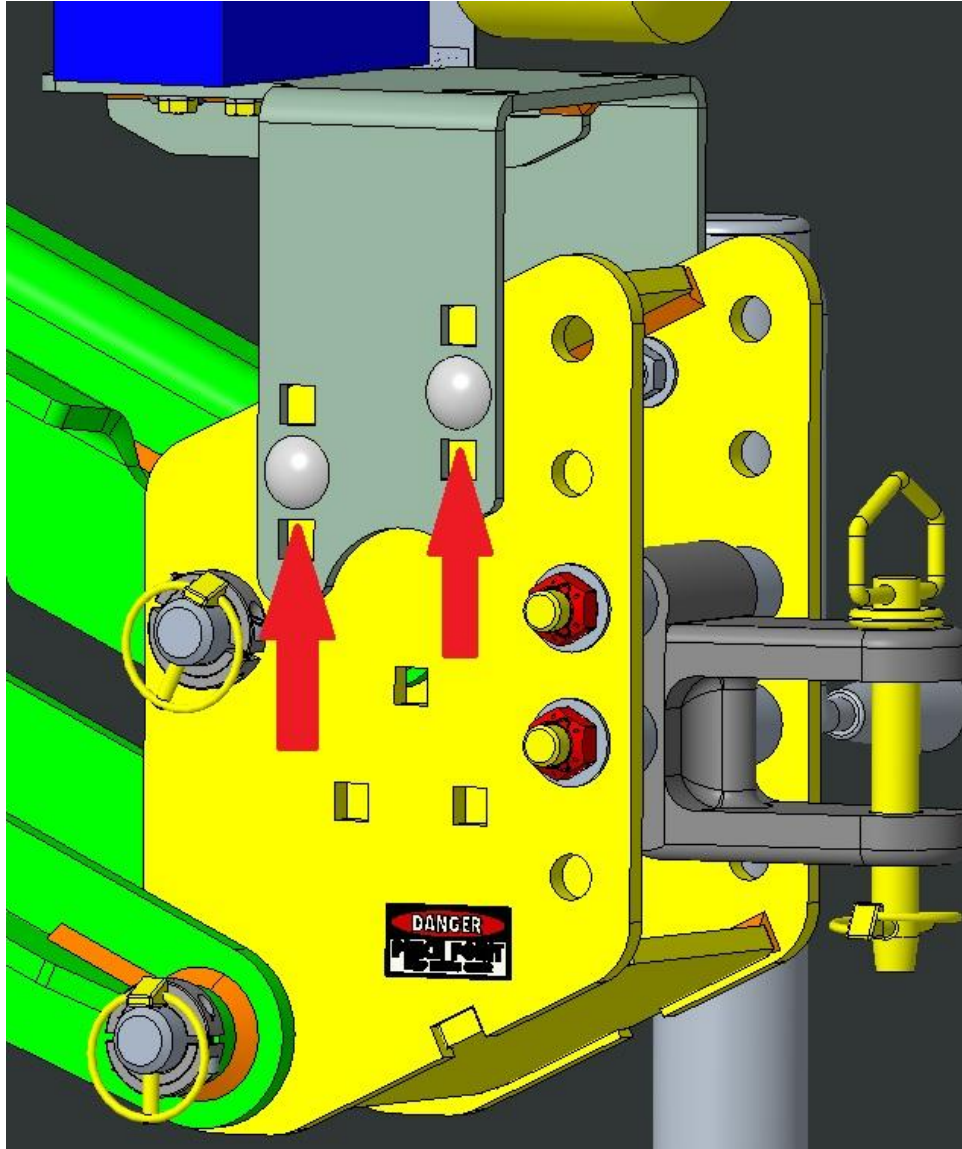

ADJUSTING FRAME HEIGHT

FIRST, RAISE THE HYDRAULIC SYSTEM AND REMOVE THE **ORANGE SAFETY STOPS** FROM EACH OF THE THREE (3) CYLINDERS. PLACE THEM ON THE T-SHAPED HOLDERS LOCATED ABOVE OR BEHIND THE CYLINDERS, AND SECURE WITH THE WIRE LOCK PIN PROVIDED.

THESE SAFETY STOPS SHOULD BE UTILIZED DURING ANY MAINTENANCE ON THE DRAG OR IF SOMEONE IS UNDERNEATH THE DRAG.

FRAME HEIGHT IS SET USING THE STOP COLLARS FOUND ON THE STOP COLLAR HOLDERS ON THE DRAG FRAME. THE COLLARS SNAP ONTO THE SILVER ROD ENDS OF EACH HYDRAULIC LIFT CYLINDER; ONE ON THE TONGUE OF THE DRAG, AND TWO IN THE REAR, ONE FOR EACH SET OF WHEELS ON THE LEFT AND RIGHT OF THE FRAME.

THE FRONT HITCH HAS COLLARS LOCATED ON THE RIGHT SIDE OF THE FRONT OF THE FRAME, AND THE REAR WHEEL LIFT'S ARE LOCATED ON THE SIDES OF THE FRAME NEAR THE WATER TANK. INCLUDED IN EACH SET ARE SIX (6) 1" COLLARS AND THREE (3) 1/4" COLLARS. THIS ALLOWS FOR SIMPLE ADJUSTMENT IN 1" AND 1/4" INCREMENTS. 1/4" COLLARS SHOULD ALWAYS BE PLACED ON THE BOTTOM OF THE HYDRAULIC CYLINDER RODS. WE RECOMMEND STARTING WITH **3"** OF STOP COLLARS.

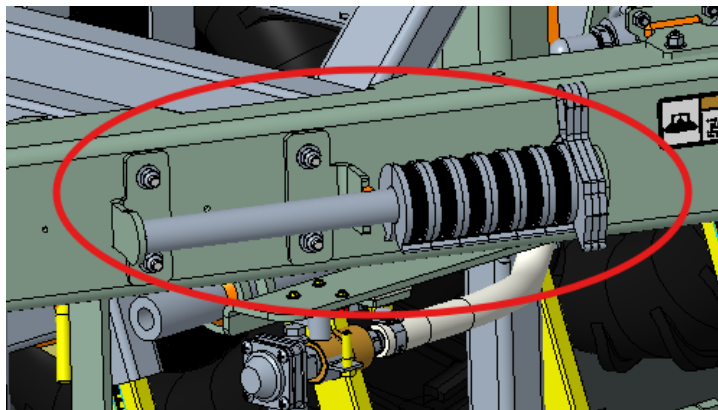
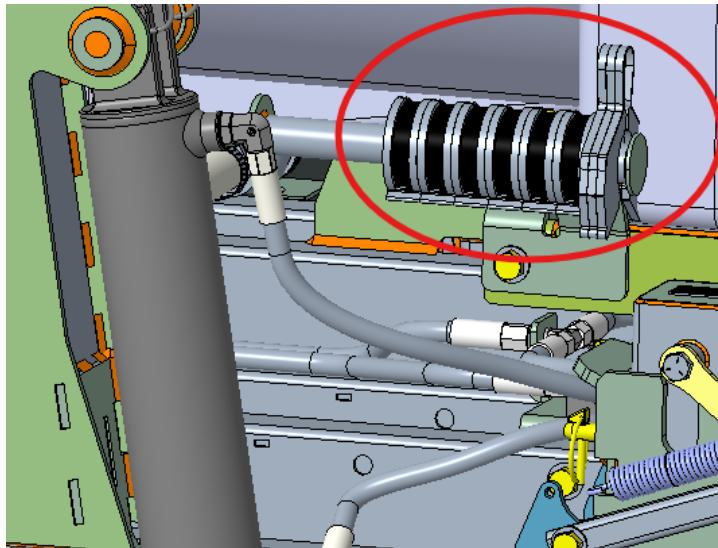

SETTING RAKE STOPS

THE RAKE LIMIT STOPS WILL NEED TO BE ADJUSTED TO SUIT YOUR DRAG AND ARENA SETUP.

AFTER SETTING UP THE DRAG AND DETERMINING YOUR FRAME HEIGHT WITH STOP COLLARS ON THE TONGUE AND WHEEL LIFTS FOR YOUR ARENA, ADJUST YOUR RAKE STOPS.

THIS IS DONE BY SLIDING THE THREE (3) RAKE STOPS AT THE REAR OF THE DRAG UNDER THE FRAME. THE RAKE ARMS SHOULD REST ON THESE WHEN THE DRAG IS AT MAX UPWARD EXTENSION TO LEAVE THE ARENA BUT SHOULD NOT BE TOUCHING WHILE DRAGGING. THIS ALLOWS THE RAKES TO "FLOAT" AND MOVE WITH THE SURFACE OF YOUR ARENA, WHILE ALSO COMING OUT OF CONTACT WITH THE GROUND TO EXIT THE ARENA.

THIS IS DONE WITH A 3/4" WRENCH.

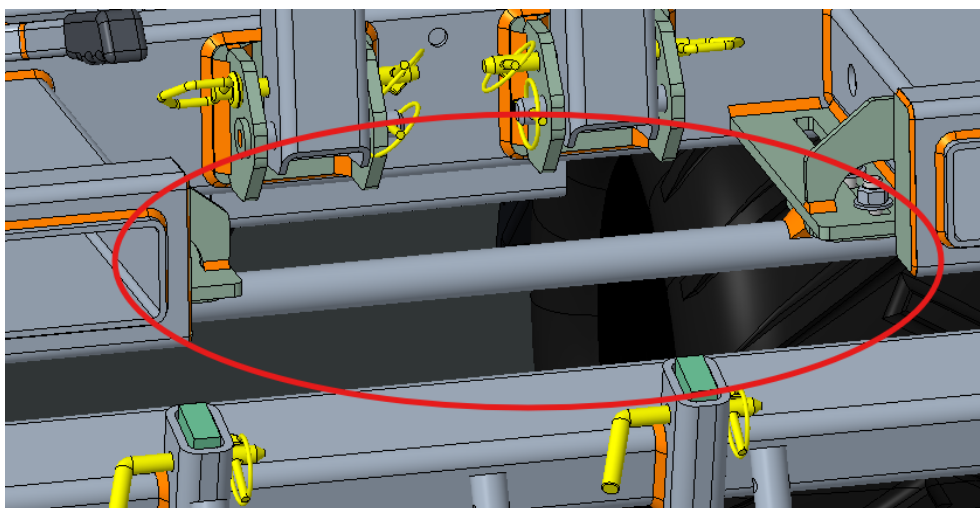
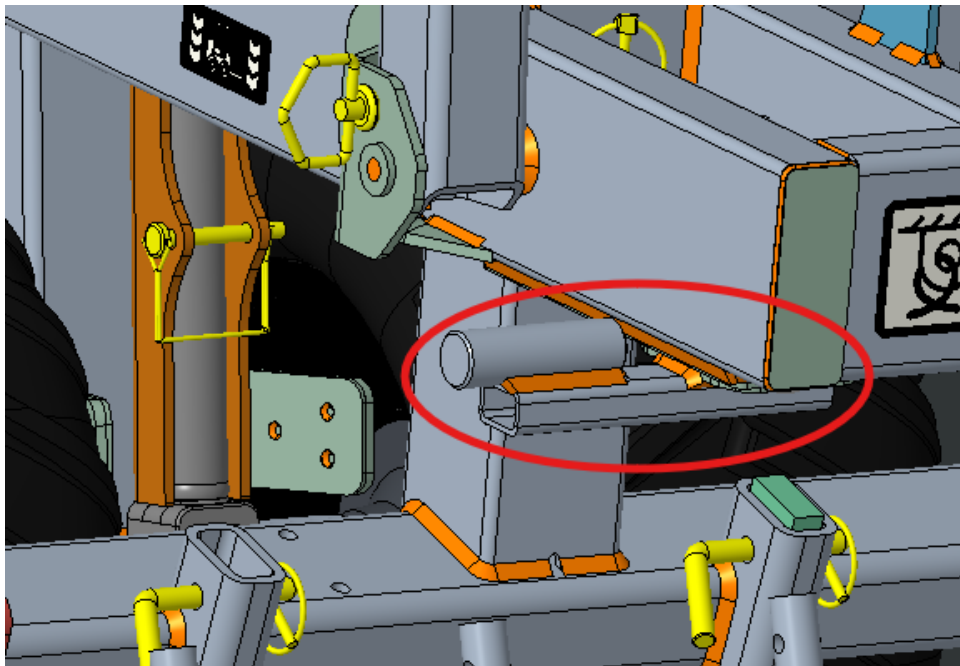

LOOSEN THE NUTS ON THE TOPS OF THE RAKE STOPS AND SLIDE THE RAKE STOP BRACKET FORWARD OR BACKWARDS. THERE ARE TWO (2) ON EACH OUTER RAKE STOP, AND FOUR (4) ON THE INNER RAKE STOP. ONCE POSITIONED, TIGHTEN THE NUTS TO LOCK THE ARMS IN PLACE.

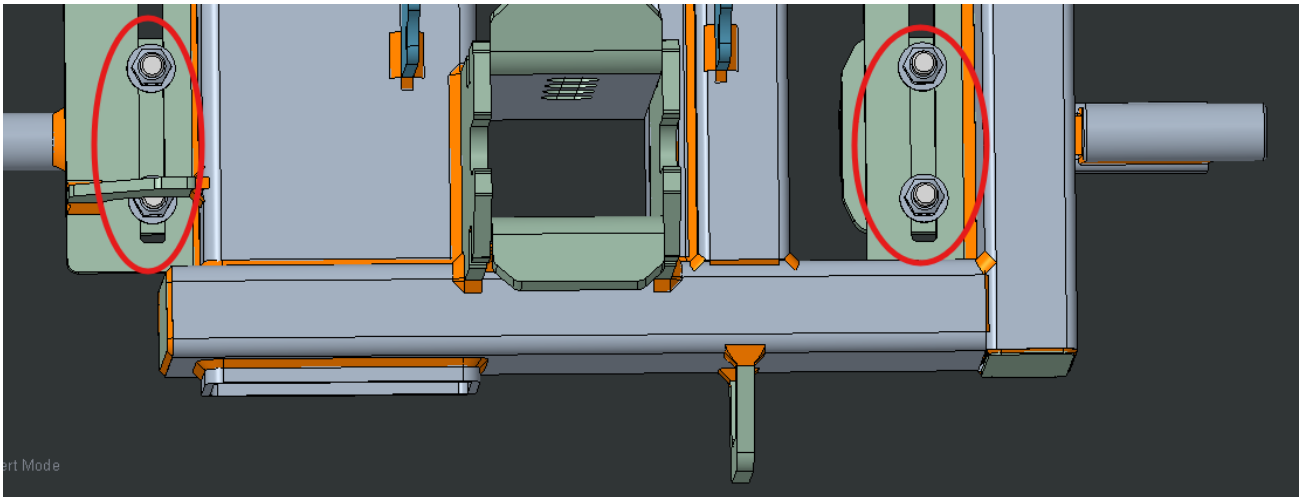
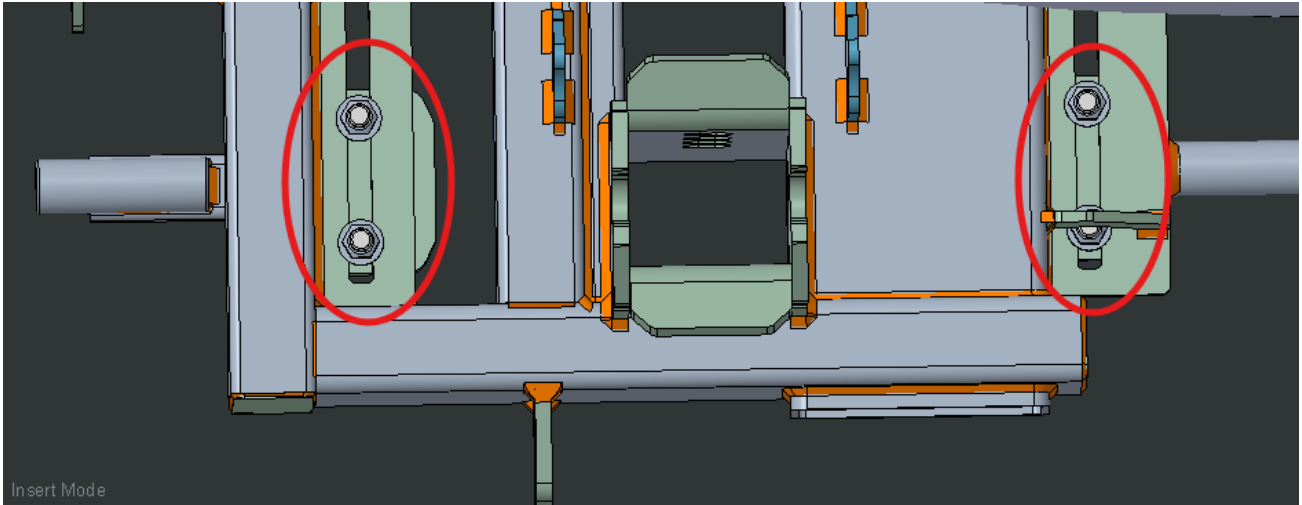

WE RECOMMEND DOING THIS IN THE ARENA WITH THE DRAG IN OPERATING POSITION AFTER PULLING FORWARD 10' WITH THE DRAG ALL THE WAY DOWN. SLIDE THE RAKE STOPS FORWARD UNTIL THE RAKES ARE FULLY TOUCHING THE GROUND, AND THERE IS APPROXIMATELY A 1/2" GAP BETWEEN THE RAKE ARM AND THE RAKE STOP. ONCE LOCKED IN PLACE, LIFT THE DRAG TO ITS TALLEST POSITION TO CHECK THAT THE RAKES ARE NO LONGER TOUCHING THE GROUND.

THIS PROCESS SHOULD ONLY NEED TO BE DONE ON INITIAL SETUP.

ADJUSTING PROFILE BLADES

ONCE YOUR FRAME HEIGHT AND RAKE STOPS ARE SET, SET YOUR PROFILE BLADE TO YOUR DESIRED DEPTH. THIS IS DONE USING THE RAPID SET HANDLES ON THE OUTER REAR OF THE DRAG.

ADJUSTING GROOMING RODS

AFTER SETTING YOUR PROFILE BLADE, SET YOUR GROOMING RODS TO YOUR DESIRED DEPTH. THIS IS DONE USING THE RAPID SET HANDLES ON THE INNER REAR OF THE DRAG.

ADJUSTING SCARIFIERS

AFTER SETTING YOUR GROOMING RODS, SET YOUR SCARIFIERS TO YOUR DESIRED DEPTH. THIS IS DONE USING THE RAPID SET HANDLES ON THE FRONT OF THE DRAG.

ADJUSTING LEVEL BLADE

AFTER SETTING THE ABOVE TOOL SETS, ADJUST YOUR LEVEL BLADE. THIS IS DONE BY USING THE TRACTOR HYDRAULIC REMOTES OR BY THE HAND PUMP, DEPENDING ON YOUR MODEL. TO USE THE HAND PUMP, SWIVEL THE HORIZONTAL HANDLE SO IT IS ABOVE THE UPWARDS OR DOWNWARDS FACING ARROWS, AND MOVE THE HANDLE ROD UP AND DOWN.



NOTE: ON AN 8' MODEL, THE HAND PUMP HANDLE **MUST** BE PLACED BACK ON ITS HOLDER ROD. ON A 10' MODEL, USE THE INCLUDED BOLT TO LOCK THE HANDLE IN PLACE.

RAPID SET HANDLES EXPLAINED

RAPID SET HANDLES ALLOW FOR PRECISE, 1/4" INCREMENTS OF TRAVEL FOR YOUR SCARIFIERS, PROFILE BLADES, AND GROOMING RODS.

TO ADJUST SETTINGS, REMOVE THE LONG PIN FROM ONE SIDE OF THE DRAG AND RAISE OR LOWER UP TO 2" AT MOST AT ONE TIME. AFTER SETTING ONE SIDE, ADJUST THE OTHER TO MATCH. THIS IS DONE BY VERIFYING PIN SETTING USING THE ALPHANUMERIC INDICATORS ON EACH HANDLE SET.

THE LETTERS SPECIFY PIN SETTING ON THE FRAME, WHILE THE NUMBERS SPECIFY PIN SETTING ON THE SPECIFIC TOOL SET YOU ARE ADJUSTING. THE HANDLES ATTACHED TO THE FRAME POCKETS HAVE SLOTS THAT ARE LABELED **A THROUGH D**. THE TUBING HAS HOLES NUMBERED **1 THROUGH 6**. THE COMBINATION OF THESE ALLOWS YOU TO ENSURE BOTH SIDES ARE SET THE SAME AND MOVE IN 1/4" TO 1" INCREMENTS.

THIS IS DONE BY READING THE NUMBER ASSOCIATED WITH THE LOWEST PIN HOLE VISIBLE ABOVE THE CHANNEL THE TOOL SET SITS INSIDE, AND THE LETTER ASSOCIATED WITH THE HOLE THE PIN IS INSERTED INTO.

FOR EXAMPLE, THE BELOW TOOLSET IS PINNED IN **HOLE 3A**.

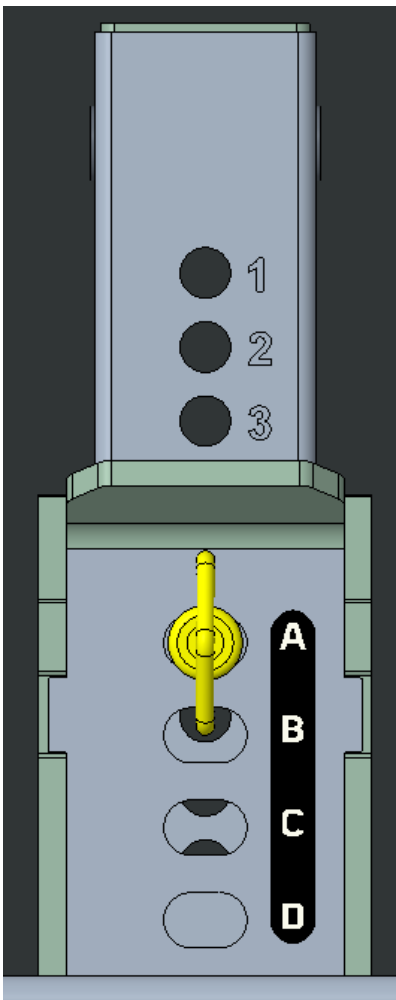

TO MOVE THE TOOL SET **DOWN BY 1/4"**, MOVE THE PIN FROM ONE LETTER TO THE NEXT DOWN, WHILE LOWERING THE TOOL SET SLIGHTLY. FOR EXAMPLE, 3A TO 3B, 3B TO 3C, 3C TO 3D, OR 3D TO 2A. THE SAME ADJUSTMENT APPLIES IN REVERSE TO RAISE THE TOOL SET.

TO MOVE THE TOOL SET **DOWN BY 1/2"**, MOVE THE PIN FROM ONE LETTER TO THE NEXT HOLE TWO DOWN, WHILE LOWERING THE TOOL SET SLIGHTLY. FOR EXAMPLE, 3A TO 3C, 3B TO 3D, 3C TO 2A, OR 3D TO 2B. THE SAME ADJUSTMENT APPLIES IN REVERSE TO RAISE THE TOOL SET.

TO MOVE THE TOOL SET **DOWN BY 3/4"**, MOVE THE PIN FROM ONE LETTER TO THE NEXT HOLE THREE DOWN, WHILE LOWERING THE TOOL SET SLIGHTLY. FOR EXAMPLE, 3A TO 3D, 3B TO 2A, 3C TO 2B, OR 3D TO 2C. THE SAME ADJUSTMENT APPLIES IN REVERSE TO RAISE THE TOOL SET.

TO MOVE THE TOOL SET **DOWN BY 1"**, USE THE SAME LETTER HOLE WHILE LOWERING THE TOOL SET DOWN TO THE NEXT NUMBER HOLE VISIBLE. THIS WILL RESULT IN 1" OF CHANGE IN HEIGHT. FOR EXAMPLE, 3C TO 2C, OR 2A TO 1A. THE SAME ADJUSTMENT APPLIES IN REVERSE TO RAISE THE TOOL SET.

DEPTH CHART SETTINGS

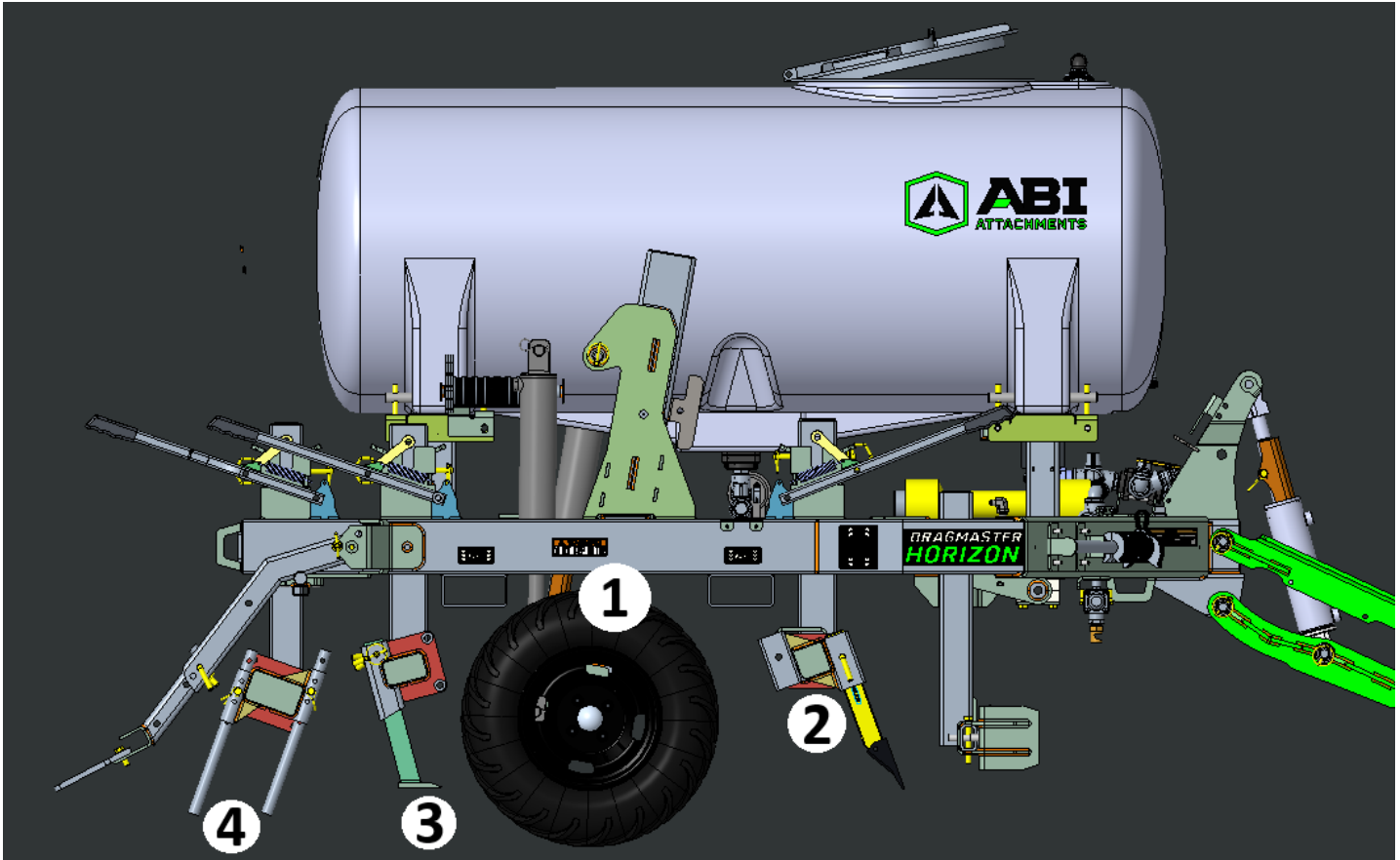

THE BELOW TABLE DOES NOT ACCOUNT FOR WEAR OF COMPONENTS
A FULL TANK OF WATER MAY INCREASE DEPTHS UP TO 1.5"

YOUR ACTUAL DEPTHS MAY DIFFER

3" OF WHEEL SPACERS			
1			
MAX DEPTH	SCARIFIERS 2	PROFILE BLADES 3	GROOMING RODS 4
1"	4C	2B	5D
1 1/2"	3A	2D	4B
2"	3C	1B	4D
2 1/2"	2A	1D	3B
3"	2C	0B	3D
3 1/2"	1A	0D	2B
4"	1C	-1B	2D

MAINTENANCE

GREASE

MAINTAINING YOUR DRAGMASTER HORIZON IS AN IMPORTANT PART OF OPERATING THE TOOL. CONTINUALLY INSPECT THE TOOL FOR WEAR AND DAMAGE, AND REPLACE PARTS AS NEEDED. THERE ARE EIGHT (8) GREASE ZERKS ON THE FRAME OF THE DRAG, AND FOUR (4) ON THE WHEEL HUBS.

THE FRAME GREASE ZERKS ARE LOCATED ON THE WHEEL LIFT TUBES, ONE ON EACH SIDE OF THE TUBE. THE FRAME GREASE ZERKS SHOULD BE GREASED **EVERY 40 HOURS**, OR ONCE **EVERY TWO MONTHS**.

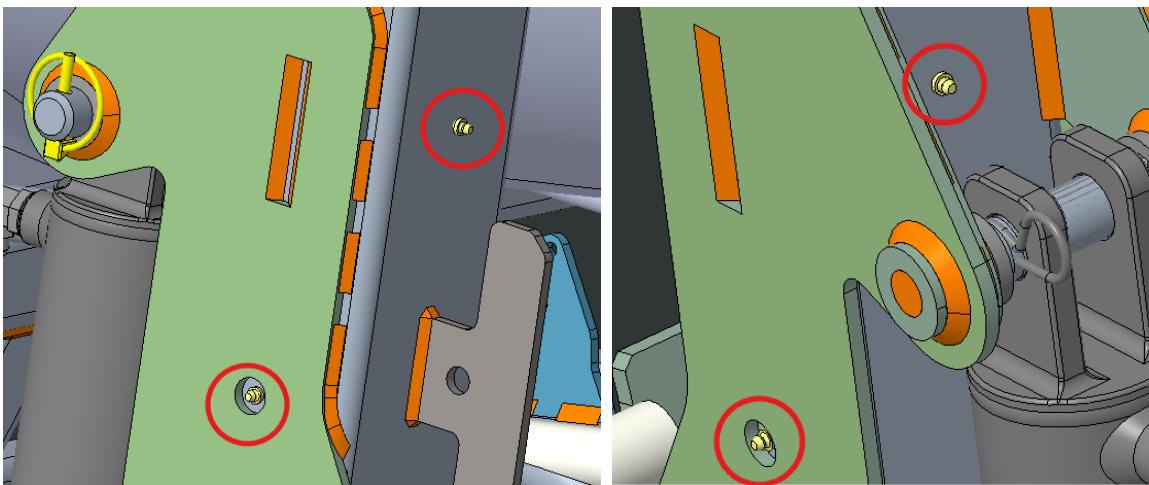

THERE ARE FOUR (4) GREASE ZERKS ON THE WHEEL LIFTS, ONE ON EACH WHEEL HUB. THESE ARE ACCESSED ON THE BACKSIDE OF THE RIM, BETWEEN EACH PAIR OF WHEELS. WHEEL HUB GREASE ZERKS SHOULD BE GREASED **EVERY 20 HOURS**, OR **ONCE PER MONTH**.

WINTERIZING

THE WATER SYSTEM ON THE DRAGMASTER HORIZON **MUST BE WINTERIZED** ANY TIME THE TEMPERATURE IS PREDICTED TO DROP BELOW FREEZING (32°F). THIS IS DONE BY EMPTYING THE WATER TANK AND ADDING 2-3 GALLONS OF RV ANTIFREEZE (USUALLY PINK IN COLOR). WHILE CONNECTED TO THE TRACTOR, AND WITH THE RECIRC VALVE OPEN, TURN THE PTO PUMP ON AND CIRCULATE THE RV ANTIFREEZE THROUGH ALL SYSTEMS. TURN OFF THE PTO PUMP ONCE THE RV ANTIFREEZE HAS REACHED THE SPRAY NOZZLES.

OPERATOR CHECKLIST

CAUTION! AVOID INJURY!

- ✓ READ AND FOLLOW THE SAFETY SECTION STARTING ON PAGE 4 CAREFULLY
- ✓ READ ALL OF THE SETUP REQUIREMENTS SECTIONS
- ✓ REVIEW YOUR TRACTOR'S OPERATING INSTRUCTIONS
- ✓ CHECK THAT THE DRAGMASTER HORIZON IS SECURELY AND PROPERLY HITCHED TO THE TRACTOR
- ✓ CHECK THAT THE DRAGMASTER HORIZON'S HYDRAULIC HOSES ARE SECURELY AND PROPERLY ATTACHED TO THE TRACTOR
- ✓ CHECK THAT ALL SAFETY LABELS ARE INSTALLED AND IN GOOD CONDITION, REPLACE IF DAMAGED
- ✓ CHECK THE DRAGMASTER HORIZON INITIALLY AND PERIODICALLY FOR LOOSE BOLTS AND PINS, AS WELL AS THE HYDRAULIC SYSTEM FOR LEAKS. REFER TO THE MAINTENANCE SECTION ON PAGE 29
- ✓ CHECK INITIALLY AND PERIODICALLY THAT ALL DRAG COMPONENTS ARE LEVEL AND THAT ALL DESIRED COMPONENTS ARE ENGAGING WITH THE GROUND SURFACE.
- ✓ KNOW YOUR CONTROLS AND HOW TO STOP TRACTOR AND ENGINE QUICKLY IN AN EMERGENCY
- ✓ DO NOT ALLOW RIDERS ON THE ABI DRAGMASTER HORIZON AT ANY TIME
- ✓ CHECK THAT YOUR TRACTOR ROPS AND SEATBELT ARE IN GOOD CONDITION. KEEP SEAT BELT SECURELY FASTENED DURING OPERATION

ESCAPING FLUID UNDER HIGH PRESSURE CAN PENETRATE THE SKIN AND CAUSE SERIOUS INJURY. DO NOT USE BODY PARTS, SUCH AS HANDS, TO DETECT LEAKS IN THE HYDRAULIC SYSTEM OR OTHER LINES. **DO NOT ATTEMPT TO CHANGE OR REMOVE LINES WHILE UNIT IS UNDER PRESSURE.**

REPLACEMENT PARTS

SOME COMPONENTS ARE CONSIDERED WEAR PARTS (SCARIFIERS, GROOMING RODS, CONTACT POINTS, ETC.) AND WILL NEED TO BE REPLACED OVER TIME. TO OBTAIN PARTS FOR THE DRAGMASTER HORIZON, PLEASE CONTACT OUR CUSTOMER SERVICE TEAM AT (877) 788-7253

EXAMPLE WEAR PARTS: LEVEL BLADE BLADES, SCARIFIERS, PROFILE BLADES, GROOMING RODS, RAKE INNER SECTIONS, RAKE OUTER SECTIONS, TIRES, HUBS

SPECIFICATIONS

ABI DRAGMASTER HORIZON	8'	10'	8' W/ WATER	10' W/ WATER
DRAG TYPE	TRACTOR TOWABLE		TRACTOR TOWABLE	
MAX WORKING WIDTH	94.75" (7' 10.75")	118.75" (9' 10.75")	94.75" (7' 10.75")	118.75" (9' 10.75")
MAX UNIT WIDTH	94.75" (7' 10.75")	118.75" (9' 10.75")	94.75" (7' 10.75")	118.75" (9' 10.75")

TOW VEHICLE REQ.

ABI DRAGMASTER HORIZON	8'	10'	8' W/ WATER	10' W/ WATER
VEHICLE TYPE	UTILITY TRACTOR W/DRAW BAR		UTILITY TRACTOR W/DRAW BAR	
MIN. HORSEPOWER	50 HP	62 HP	55 HP	67 HP
MAX. HORSEPOWER	125 HP	125 HP	125 HP	125 HP
4 WHEEL DRIVE	REQUIRED	REQUIRED	REQUIRED	REQUIRED
HYDRAULIC REMOTES NEEDED	1 REMOTE / 2 REMOTES W/HYDRO BLADE TRACTOR CONTROL		1 REMOTE / 2 REMOTES W/HYDRO BLADE TRACTOR CONTROL	
MIN TRACTOR WEIGHT	3,700 LBS.	5,000 LBS.	4,200 LBS.	5,500 LBS.
FRONT WEIGHT NEEDED	YES	YES	YES	YES
TIRE TYPE	LUG TRACTOR TIRES		LUG TRACTOR TIRES	
IDEAL OUTSIDE TREAD WIDTH	UP TO 72" (6')	UP TO 96" (8')	UP TO 72" (6')	UP TO 96" (8')
MAX OUTSIDE TREAD WIDTH	78" (6' 6")	102" (8' 6")	78" (6' 6")	102" (8' 6")

FRAME CONSTRUCTION

ABI DRAGMASTER HORIZON	8'	10'	8' W/ WATER	10' W/ WATER
TYPE	COMMERCIAL		COMMERCIAL	
MATERIAL	TUBE STEEL		TUBE STEEL	
TRANSPORT	TOWABLE W/HYDRAULIC WHEEL LIFT		TOWABLE W/HYDRAULIC WHEEL LIFT	
DEPTH ADJUSTMENT INCREMENT	¼"	¼"	¼"	¼"
LEVELING ADJUSTMENT	INFINITE	INFINITE	INFINITE	INFINITE
TIRE SIZE	24" DIAMETER X 12" WIDTH X 12" RIM	24" DIAMETER X 12" WIDTH X 12" RIM	24" DIAMETER X 12" WIDTH X 12" RIM	24" DIAMETER X 12" WIDTH X 12" RIM
TIRE TYPE	BAR TREAD TIRE - AIR FILLED		BAR TREAD TIRE - AIR FILLED	
# OF TIRES	4	4	4	4

LEVELING BLADE

ABI DRAGMASTER HORIZON	8'	10'	8' W/ WATER	10' W/ WATER
TYPE	HYDRAULIC CONTROL		HYDRAULIC CONTROL	
WORKING WIDTH	86.125" (7' 2.125")	110.75" (9' 2.75")	86.125" (7' 2.125")	110.75" (9' 2.75")
SELECTABLE DOWN POSITION	YES, ¼" INCREMENTS	YES, ¼" INCREMENTS	YES, ¼" INCREMENTS	YES, ¼" INCREMENTS
MANUAL HAND PUMP CONTROL*	OPTIONAL, NO ADDITIONAL REAR REMOTES NEEDED		OPTIONAL, NO ADDITIONAL REAR REMOTES NEEDED	
HYDRAULIC TRACTOR CONTROL*	OPTIONAL, 2 TOTAL SETS OF REMOTES NEEDED		OPTIONAL, 2 TOTAL SETS OF REMOTES NEEDED	
CUTTING EDGE	SCALLOPED, REPLACEABLE IN 2 SECTIONS		SCALLOPED, REPLACEABLE IN 2 SECTIONS	

***SELECT ONLY ONE**

SCARIFIERS

ABI DRAGMASTER HORIZON	8'	10'	8' W/ WATER	10' W/ WATER
MANUAL RAPID-SET SYSTEM	YES	YES	YES	YES
DEPTH ADJUSTMENT INCREMENT	¼"	¼"	¼"	¼"
WORKING WIDTH	76.375" (6' 4.375")	105.875" (8' 9.875")	76.375" (6' 4.375")	105.875" (8' 9.875")
WORKING DEPTH	0" - 8"	0" - 8"	0" - 8"	0" - 8"
# OF SCARIFIERS	8	12	8	12
OPTIONAL 2ND ROW	AVAILABLE - ADD 5HP	AVAILABLE - ADD 5HP	AVAILABLE - ADD 5HP	AVAILABLE - ADD 5HP
# OF SCARIFIERS W/2ND ROW	17	23	17	23
TYPE	RIGID SHANK - WITH REPLACEABLE TIP (BOLT-ON)		RIGID SHANK - WITH REPLACEABLE TIP (BOLT-ON)	
SCARIFIER SHANK LENGTH	12"	12"	12"	12"

PROFILE BLADES

ABI DRAGMASTER HORIZON	8'	10'	8' W/ WATER	10' W/ WATER
MANUAL RAPID-SET SYSTEM	YES	YES	YES	YES
DEPTH ADJUSTMENT INCREMENT	¼"	¼"	¼"	¼"
WORKING WIDTH	83.75" (6' 11.75")	111.75" (9' 3.75")	83.75" (6' 11.75")	111.75" (9' 3.75")
WORKING DEPTH	0" - 6.5"	0" - 6.5"	0" - 6.5"	0" - 6.5"
# OF BLADES	3	4	3	4

GROOMING RODS

ABI DRAGMASTER HORIZON	8'	10'	8' W/ WATER	10' W/ WATER
MANUAL RAPID-SET SYSTEM	YES	YES	YES	YES
DEPTH ADJUSTMENT INCREMENT	¼"	¼"	¼"	¼"
WORKING WIDTH	79.75" (6' 7.75")	106.25" (8' 10.25")	79.75" (6' 7.75")	106.25" (8' 10.25")
WORKING DEPTH	0" - 10"	0" - 10"	0" - 10"	0" - 10"
GROOMING ROD SPACING	7.875" (7 7/8")	7.875" (7 7/8")	7.875" (7 7/8")	7.875" (7 7/8")
FRONT TO REAR SPACING	4.4375 (4 7/16")	4.4375 (4 7/16")	4.4375 (4 7/16")	4.4375 (4 7/16")
# OF GROOMING RODS	21	27	21	27
GROOMING ROD LENGTH	16"	16"	16"	16"

FINISH RAKE

ABI DRAGMASTER HORIZON	8'	10'	8' W/ WATER	10' W/ WATER
TYPE	FLOATING, SPLIT IN TWO SECTIONS, & ADJUSTABLE		FLOATING, SPLIT IN TWO SECTIONS, & ADJUSTABLE	
WORKING WIDTH	94.75" (7' 10.75")	118.75" (9' 10.75")	94.75" (7' 10.75")	118.75" (9' 10.75")
FLOATING SPLIT RAKE	YES	YES	YES	YES
RAKE MATERIAL	1/2" STEEL	1/2" STEEL	1/2" STEEL	1/2" STEEL
REPLACEABLE	YES, IN SECTIONS	YES, IN SECTIONS	YES, IN SECTIONS	YES, IN SECTIONS
FLARED ENDS	YES	YES	YES	YES

WATER SYSTEM

ABI DRAGMASTER HORIZON	8'	10'	8' W/ WATER	10' W/ WATER
WATER CAPACITY	-	-	340 GALLONS	340 GALLONS
PTO PUMP	-	-	YES	YES
# OF NOZZLES	-	-	2	2
GPM RANGE OF PUMP	-	-	15-25GPM AT 540RPM	15-25GPM AT 540RPM
AUTOFILL SHUTOFF VALVE	-	-	YES	YES
FULL DRAIN TANK	-	-	YES	YES
SPRAY HOSE	-	-	AVAILABLE OPTION	AVAILABLE OPTION
REAR SINGLE-POINT SPRAY	-	-	AVAILABLE OPTION	AVAILABLE OPTION

OPTIONS AVAILABLE

ABI DRAGMASTER HORIZON	8'	10'	8' W/ WATER	10' W/ WATER
MANUAL HAND PUMP BLADE CONTROL	AVAILABLE OPTION		AVAILABLE OPTION	
TRACTOR HYDRAULIC BLADE CONTROL	AVAILABLE OPTION (REQUIRES 2 HYDRO REMOTES)		AVAILABLE OPTION (REQUIRES 2 HYDRO REMOTES)	
WALL / RAIL BLADE	AVAILABLE OPTION		AVAILABLE OPTION	
REAR SINGLE-POINT SPRAY	-		AVAILABLE	
SPRAY HOSE	-		AVAILABLE	
2ND ROW OF SCARIFIERS	AVAILABLE OPTION - REQUIRES 5HP MORE		AVAILABLE OPTION - REQUIRES 5HP MORE	
PUSH BLADE	AVAILABLE OPTION - REQUIRES 5HP MORE		AVAILABLE OPTION - REQUIRES 5HP MORE	

WEIGHTS & DIMS

ABI DRAGMASTER HORIZON	8'	10'	8' W/ WATER	10' W/ WATER
UNIT WEIGHT	2,635 LBS.	2,945 LBS	2,640 LBS.	2,950 LBS.
UNIT WEIGHT + WATER	-	-	5,515 LBS.	5,785 LBS.
SHIPPING WEIGHT	2,635 LBS.	2,945 LBS	2,640 LBS.	2,950 LBS.
UNIT DIMENSIONS	95"W X 152" L X 48" H	119" W X 152" L X 48" H	95" W X 152" L X 70" H	119" W X 152" L X 70" H
SHIPPING DIMENSIONS	95" W X 100" L X 48" H	119" W X 100" L X 48" H	95" W X 100" L X 70" H	119" W X 100" L X 70" H

LIMITED WARRANTY

ABI DRAGMASTER HORIZON	8'	10'	8' W/ WATER	10' W/ WATER
FARM & RANCH USE	12-MONTH		12-MONTH	
COMMERCIAL USE	12-MONTH		12-MONTH	

EXPLODED VIEWS FOR ASSEMBLY

EXPLODED VIEWS FOR THE RAIL BLADE, REAR SPRAY, AND 10FT EXTENSION OPTIONS ARE LOCATED ON THE FOLLOWING PAGES TO ASSIST IN ASSEMBLY.

NOT APPLICABLE TO ALL MODELS OR CONFIGURATIONS.

NO. 1:

- 1. PART MUST BE FREE OF CRACKS, BURRS, MILD SPALLS, AND RUNS IN FINISH.
- 2. ALL GEOMETRY NOT INCLUDED ON PRINT TO COME FROM ELECTRONIC FILES.

ITEM	PART #	DESCRIPTION	QTY	REV	ALT. PN
1	10-20224	HITCH P.W. 5/8"X5" ZINC	1		-
2	10-20232	LINCH PIN 1/4"X1.25" ZINC	1		FM04LP
3	10-20710	KIT: HARDWARE: RAIL BLADE ASM	1	A	-
4	10-33805	TUBE: RAIL BLADE TUBE: DWP	1	A	-
5	10-11242	WHEEL: RAIL BLADE SLIDE: DWP	1	A	-
6	10-60039	WHEEL: RAIL BLADE: TR3E PASCAL	1		OP.1413

REV	A	PRODUCTION RELEASED	9/18/2025	DATE	JTL	APPROVED
-----	---	---------------------	-----------	------	-----	----------

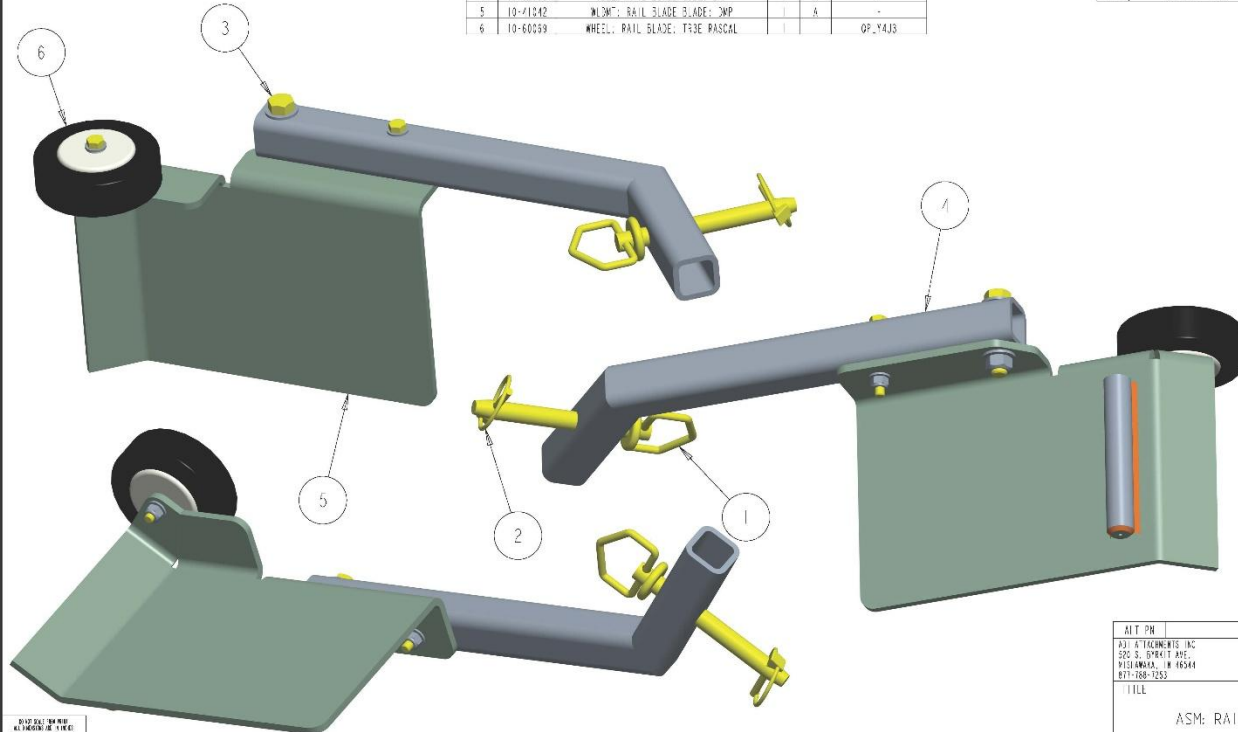

REV	A	PRODUCTION RELEASED	9/18/2025	DATE	JTL	APPROVED
-----	---	---------------------	-----------	------	-----	----------

MAT'L	AS SPECIFIED	SURFACE AREA (in ²)	VOLUME (in ³)	WEIGHT (LBS)
FINISH	AS SPECIFIED	525.044	67.157	15.152

DRAWN BY:	JJR
DATE:	8/27/25

DRAWING STATUS	PRODUCTION
----------------	------------

ALT. PN		
P31 ATTACHMENTS INC 292 S. DYKST AVE. VICTORVILLE, IN 48344 877-788-7253		
TITLE		
ASM: RAIL BLADE: CMP		
SIZE	DWG NO.	REV
3	10-90884	A
SCALE	0.375	SHEET 1 OF 2

NO. 1:

- 1. PART MUST BE FREE OF CRACKS, BURRS, MILD SPALLS, AND RUNS IN FINISH.
- 2. ALL GEOMETRY NOT INCLUDED ON PRINT TO COME FROM ELECTRONIC FILES.

ITEM	PART #	DESCRIPTION	QTY	REV	ALT. PN
1	0-23224	HITCH PIN: 5/8"X5" ZINC	1		-
2	0-23232	LINCH PIN: 1/4"X1.25" ZINC	1		FM04LP
3	0-23710	KIT: HARDWARE: RAIL BLADE ASM	1	A	-
4	0-33805	TUBE: RAIL BLADE TUBE: DWP	1	A	-
5	0-11242	WHEEL: RAIL BLADE SLIDE: DWP	1	A	-
6	0-60039	WHEEL: RAIL BLADE: TR3E PASCAL	1		OP1413

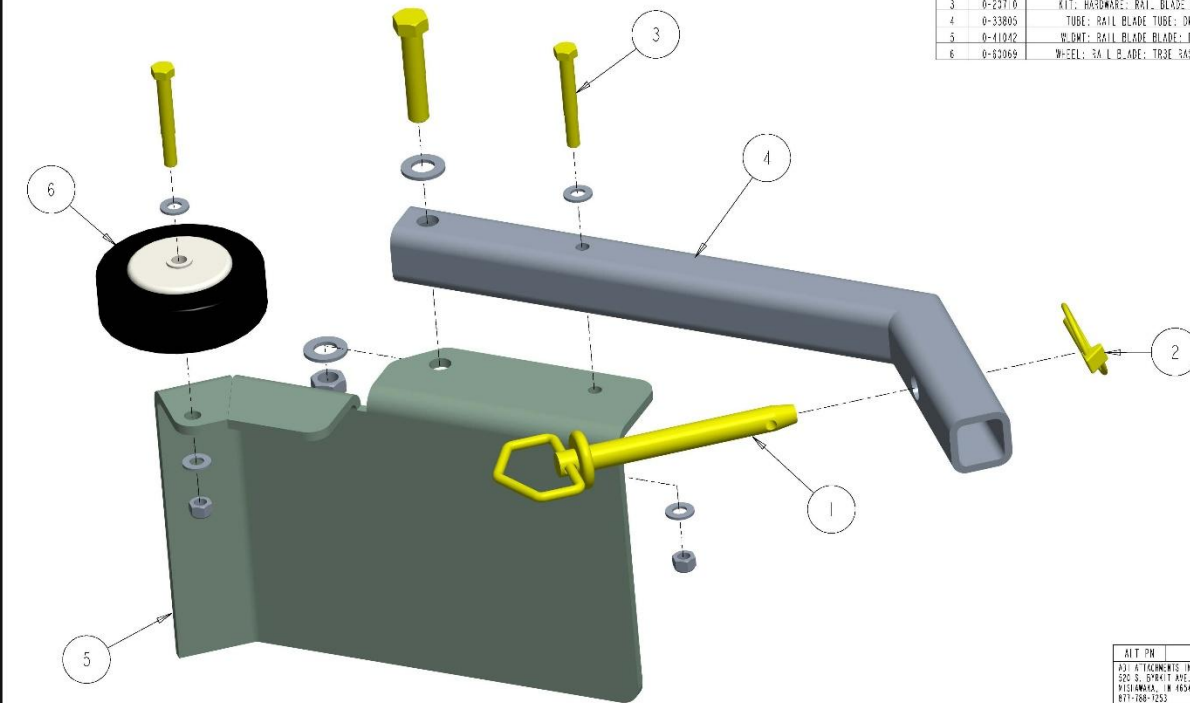

REV	A	PRODUCTION RELEASED	9/18/2025	DATE	JTL	APPROVED
-----	---	---------------------	-----------	------	-----	----------

MAT'L	AS SPECIFIED	SURFACE AREA (in ²)	VOLUME (in ³)	WEIGHT (LBS)
FINISH	AS SPECIFIED	525.044	67.157	15.152

DRAWN BY:	JJR
DATE:	8/27/25

DRAWING STATUS	PRODUCTION
----------------	------------

ALT. PN		
P31 ATTACHMENTS INC 292 S. DYKST AVE. VICTORVILLE, IN 48344 877-788-7253		
TITLE		
ASM: RAIL BLADE: CMP		
SIZE	DWG NO.	REV
3	10-90884	A
SCALE	0.300	SHEET 2 OF 2

NOTE:

1. PART MUST BE FREE OF CRACKS, BURRS, MILD SPALLER, AND RUNS A FINISH.
2. ALL GEOMETRY NOT INCLUDED ON PRINT TO COME FROM ELECTRONIC FILES.

ITEM	PART #	DESCRIPTION	QTY	REV	ALT PN
1	10-20050	1/2"-3 TOP LOCKER	1		FW285LN
2	10-20128	5/16" SAE WASHER ZNC	1		FW285D
3	10-20185	HX HD BOLT: 1/2-13 2.5" ZINC GR5	1		
4	10-20194	F.T. WS-3, 1/2 SAE, CL ZINC	2		FW285AE
5	10-20232	WASHER NUT: 5/16"-18-2 INCL GR 5	2		FW285LN
6	10-20338	HX HD BOLT: 5/16-18 2.5" ZINC GR5	2		

REV	DESCRIPTION	DATE	APPROVED
A	PRODUCTION RELEASED	9/18/2025	LTL

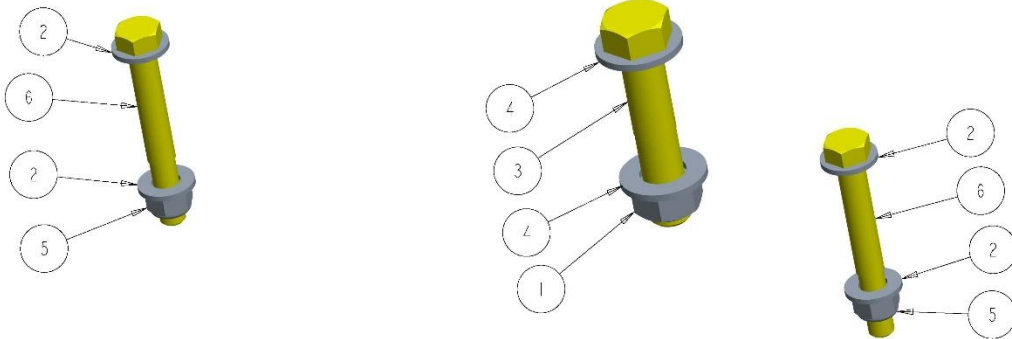

PROPERTY	VALUE
DATE	8/28/2025
TIME	10:10:10
USER	ADMIN
HOST	ADMIN
IP	192.168.1.1

MATERIAL	AS SPECIFIED	SURFACE AREA (cm ²)	VOLUME (cm ³)	WEIGHT (LB)
FINISH	AS SPECIFIED	23.53	1.589	0.45
		OVERALL SIZE (in)		

DRAWN BY:	LTL
DATE:	8/28/2025

DRAWING STATUS	PRODUCT ON

ALT PN	ABE ATTACHMENTS	
P31 ATTACHMENTS INC	320 S. DYKST AVE.	
	PUEBLO, CO 81004	
	877-788-7553	
TITLE		
KIT: HARDWARE: RAIL BLADE ASM		
SIZE	DWG NO.	REV
3	10-20710	A
SCALE: 1:000		SHEET 1 OF 1

NO. 1:

- 1. PART MUST BE FREE OF CRACKS, BURRS, WELD SPATTER, AND RUNS IN FINISH.
- 2. ALL GEOMETRY NOT INCLUDED ON PRINT TO COME FROM ELECTRONIC FILES.

ITEM	PART #	DESCRIPTION	QTY	REV	ALT PN
1	10-20709	KIT, HARDWARE: RAIL BLADE ASM W/MOUNT	1	A	-
2	10-41041	MOUNT, RAIL BLADE MOUNT, DMP	1	A	-
3	10-90884	ASM: RAIL BLADE: DMP	1	A	-

REV	A	PRODUCTION RELEASED	9/18/2025	JTL
		DESCRIPTION	DATE	APPROVED

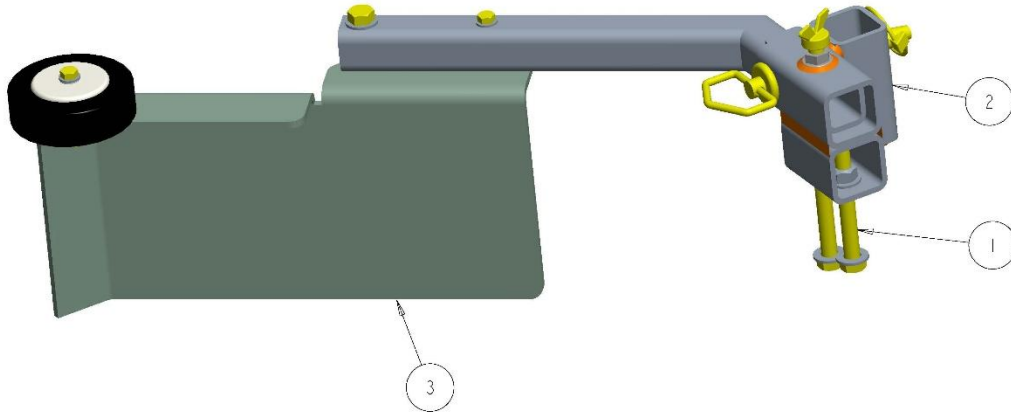

REVISED FOR NEW ALIGNMENT OF PILES ON 08/20/2025 BY JJJ TO BE ASSEMBLED TO 105
FORMER PART NUMBER 10-90884
FORMER PART NUMBER 10-90884
FORMER PART NUMBER 10-90884
FORMER PART NUMBER 10-90884
FORMER PART NUMBER 10-90884

MAT'L	AS SPECIFIED	SURFACE AREA (in ²)	VOLUME (in ³)	WEIGHT (LB)
FINISH	AS SPECIFIED	OVERALL SIZE (in)		
		823.915	94.007	22.163
		OVERALL SIZE (in)		

DRAWN BY:	JJJ
DATE:	8/22/25

DRAWING STATUS	PRODUCT ON
----------------	------------

ALT PN	
P31 ATTACHMENTS INC 202 S. DYKST AVE. PLYMOUTH, IN 46344 817-788-7553	
TITLE	
ASM: RAIL BLADE W MOUNT: DMP	
SIZE	DWG NO.
3	10-90897
SCALE	SHEET 1 OF 2
0.375	A

NO. 1:

- 1. PART MUST BE FREE OF CRACKS, BURRS, WELD SPATTER, AND RUNS IN FINISH.
- 2. ALL GEOMETRY NOT INCLUDED ON PRINT TO COME FROM ELECTRONIC FILES.

ITEM	PART #	DESCRIPTION	QTY	REV	ALT PN
1	10-20709	KIT, HARDWARE: RAIL BLADE ASM W/MOUNT	1	A	-
2	10-41041	MOUNT, RAIL BLADE MOUNT, DMP	1	A	-
3	10-90884	ASM: RAIL BLADE: DMP	1	A	-

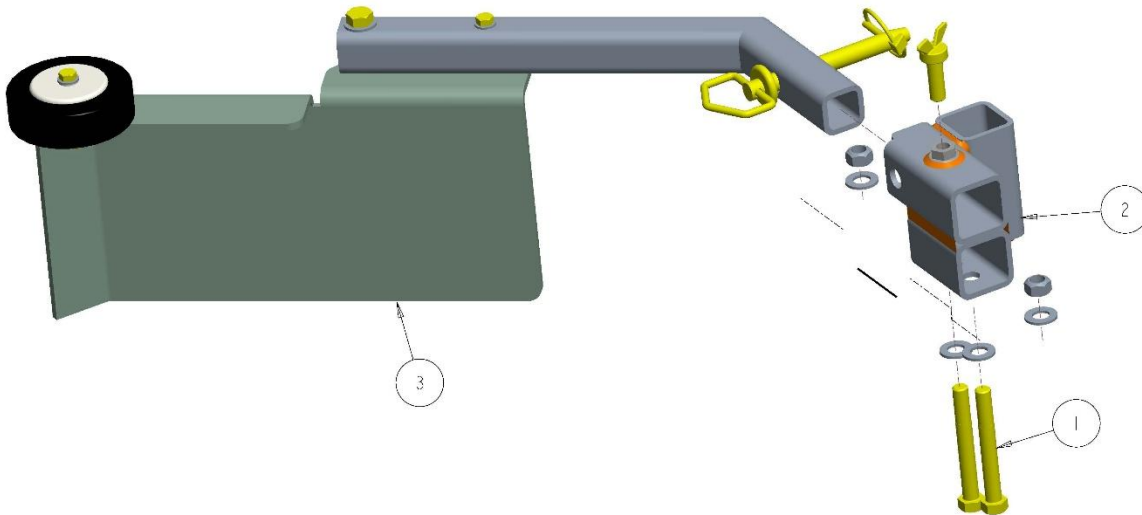

REVISED FOR NEW ALIGNMENT OF PILES ON 08/20/2025 BY JJJ TO BE ASSEMBLED TO 105
FORMER PART NUMBER 10-90884
FORMER PART NUMBER 10-90884
FORMER PART NUMBER 10-90884
FORMER PART NUMBER 10-90884
FORMER PART NUMBER 10-90884

MAT'L	AS SPECIFIED	SURFACE AREA (in ²)	VOLUME (in ³)	WEIGHT (LB)
FINISH	AS SPECIFIED	OVERALL SIZE (in)		
		823.915	94.007	22.163
		OVERALL SIZE (in)		

DRAWN BY:	JJJ
DATE:	8/22/25

DRAWING STATUS	PRODUCT ON
----------------	------------

ALT PN	
P31 ATTACHMENTS INC 202 S. DYKST AVE. PLYMOUTH, IN 46344 817-788-7553	
TITLE	
ASM: RAIL BLADE W MOUNT: DMP	
SIZE	DWG NO.
3	10-90897
SCALE	SHEET 2 OF 2
0.375	A

NOTE:

1. PART MUST BE FREE OF CRACKS, BURRS, WELD SPATTER, AND RUNS A FINISH.
2. ALL GEOMETRY NOT INCLUDED ON PRINT TO COME FROM ELECTRONIC FILES.

ITEM	PART #	DESCRIPTION	QTY	REV	ALT PN
1	10-20050	1/2"-3 TOP LNERC	2		ENG08ASLV
2	10-2014	HK HD BOLT 1/2"-13 X 2.0 NC GR5	2		
3	10-20134	F.T WS-4.112 SAE CL ZINC	4		FW28SAE
4	10-20236	WING BOLT 1/2"-13 X 1.5 ZINC GR5	1		

REV	A	PRODUCTION RELEASED DESCRIPTION	9/18/2025 DATE	UTL APPROVED
-----	---	---------------------------------	----------------	--------------

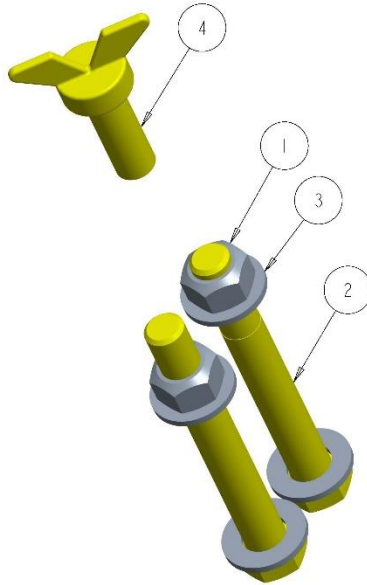

REV	A	PRODUCTION RELEASED DESCRIPTION	9/18/2025 DATE	UTL APPROVED
-----	---	---------------------------------	----------------	--------------

MATERIAL	AS SPECIFIED	SUBJECT AREA (in ²)	VOLUME (in ³)	WEIGHT (LB)
FINISH	AS SPECIFIED	33.517	3.021	0.858
		OVERALL SIZE (in)		

DRAWN BY:	LIL
DATE:	8/28/2025

DRAWING STATUS	PRODUCTION
----------------	------------

ALT PN	
P31 ATTACHMENTS INC 200 S. DYKST AVE. FREDERICK, MD 21734 877-788-7553	
TITLE	
KIT: HARDWARE: RAIL BLADE ASM W/MOUNT	
SIZE	DWG NO.
3	10-20709
SCALE	1:000
REV	A
SHEET 1 OF 1	

NO. 1:
 1. PART MUST BE FREE OF CRACKS, BURRS, WELD SPATTER, AND RUNS TO FINISH.
 2. ALL GEOMETRY NOT INCLUDED ON PRINT TO COME FROM ELECTRONIC FILES.

ITEM	PART #	DESCRIPTION	QTY	REV	ALT PN
1	10-1159	CONNECTOR: STRAIGHT 3/4" NPT, INTERNAL T=3, POLY	1		
2	10-1163	TEE: 1/2" APH/3/4" CHECK VALVE, 3/4" NPT	1		
3	10-1409	FITTING: CON & GROOVE, 1" HOSE 5/8" O.D. X 1/2" NPT	1		
4	10-1446	CLAMP: ADJUSTABLE STAND OFF SPRAY NOZZLE	1		
5	10-1531.13	HOSE: 1" ID X 1 1/8" O.D. X 82.00" L	1	A	
6	10-1195	NOZZLE: 3/4" FLZ12 SPRAY, 3/4" NPT MALE: BRASS	1		7FLZ12
7	10-1196	FITTING: BARBED HOSE FOR 1" HOSE, 3/4" NPT MALE, 90 DEG: PLASTIC	1		52 BR855
8	10-20720	KIT: HARDWARE: REAR SPRAY ASSEMBLY: DMP	1	A	
9	10-38891	BRKT: REAR SPRAY TEEJET: DMP	1	A	

REV	A	PRODUCTION RELEASED	11/10/2025	JTL
		DESCRIPTION	DATE	APPROVED

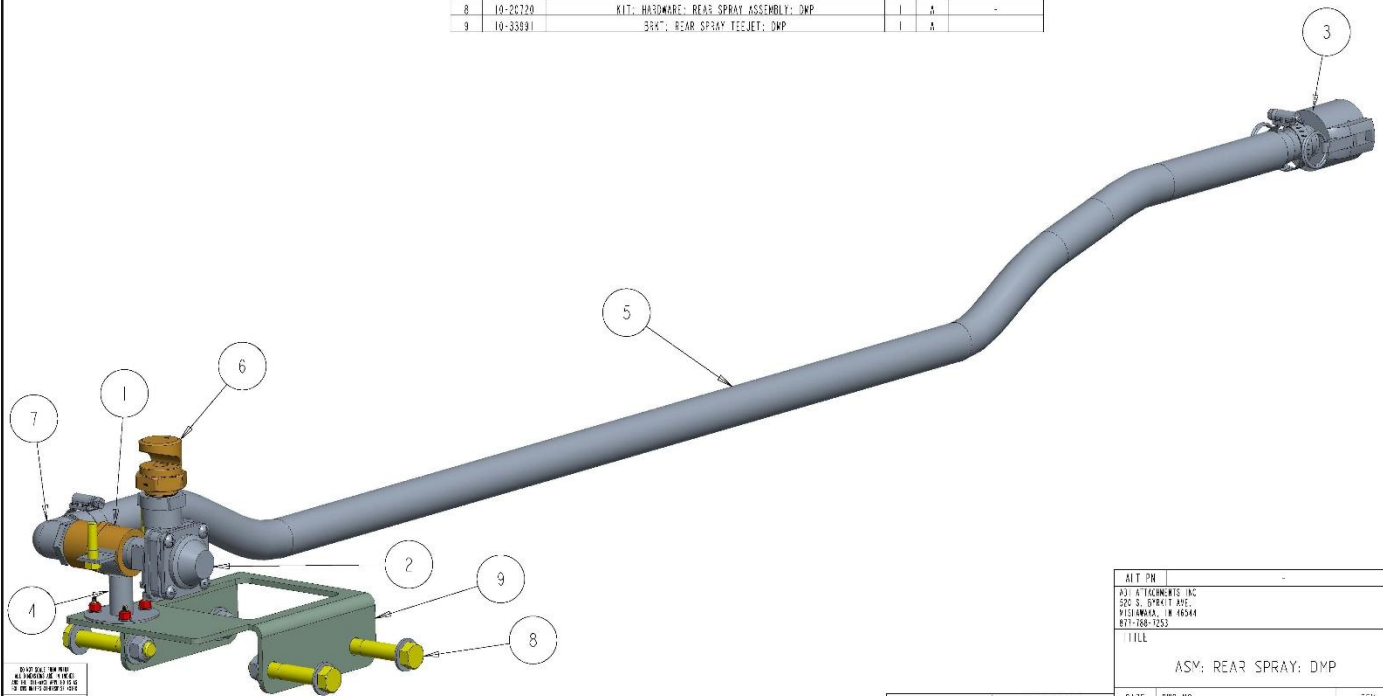

DIAPHRAGM PUMP	AS SPECIFIED			
WATER	AS SPECIFIED			
FINISH	AS SPECIFIED			

SURFACE AREA (in ²)	VOLUME (in ³)	WEIGHT (LB)
1150.848	82.129	7.785
OVERALL SIZE (in)		

DRAWN BY:	JJR
DATE:	11/10/2025

DRAWING STATUS	PRODUCT ON
----------------	------------

ALT PN	
P31 ATTACHMENTS INC 200 S. SPRAIT AVE. VICTORVILLE, IN 48544 877-788-7553	
TITLE ASY: REAR SPRAY: DMP	
SIZE	DWG NO.
3	10-90955
SCALE	SHEET 1 OF 1

NO. 1:
 1. PART MUST BE FREE OF CRACKS, BURRS, WELD SPATTER, AND RUNS TO FINISH.
 2. ALL GEOMETRY NOT INCLUDED ON PRINT TO COME FROM ELECTRONIC FILES.

ITEM	PART #	DESCRIPTION	QTY	REV	ALT PN
1	10-11540	CLAMP: WSRM-DRIVE, 1/2" O.D. HOSE, 1.3718" O.D. 1-1/2" CLAMP ID	2		
2	10-20050	NUT: SAE: 1/2-13: GR5: Z1MC	4		FN088SLM
3	10-20168	FLY HO BOLT: 1/2-13: 3" Z1MC GR5	4		
4	10-20184	FLY HO BOLT: 1/2 SAE: CL Z1MC	8		FN088SAE
5	10-20080	HK HO 50-T-5/16-18: 1.25" Z1MC GR5	2		
6	10-20673	WSHR SAE: 1/8: Z1MC	8		
7	10-20674	NUT MFLK: 8-32: Z1MC	3		
8	10-20676	50-T HEX: 1/8-32x0.75: GR5: Z1MC	3		

REV	A	PRODUCTION RELEASED	11/12/2025	JTL
		DESCRIPTION	DATE	APPROVED

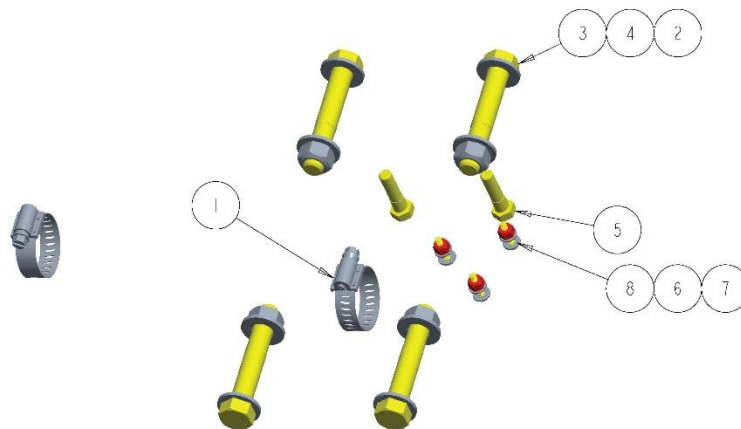

DIAPHRAGM PUMP	AS SPECIFIED			
WATER	AS SPECIFIED			
FINISH	AS SPECIFIED			

SURFACE AREA (in ²)	VOLUME (in ³)	WEIGHT (LB)
18.316	4.856	1.318
OVERALL SIZE (in)		

DRAWN BY:	LUL
DATE:	11/12/2025

DRAWING STATUS	PRODUCT ON
----------------	------------

ALT PN	
P31 ATTACHMENTS INC 200 S. SPRAIT AVE. VICTORVILLE, IN 48544 877-788-7553	
TITLE KIT: HARDWARE: REAR SPRAY ASSEMBLY: DMP	
SIZE	DWG NO.
3	10-20720
SCALE	SHEET 1 OF 1

NOTES:

- PART MUST BE FREE OF CRACKS, BURRS, WELD SPATTER, AND RUNS A FINISH.
- ALL GEOMETRY NOT INCLUDED ON PRINT TO COME FROM ELECTRONIC FILES.

ITEM	PART #	DESCRIPTION	QTY	REV	ALT PN
1	10-2097	KIT: HARDWARE: SCARIFIER EXTENSION: DMP	1	A	-
2	10-4028	12" SCARIFIER WITH HARDWARE	1	A	SCARSHANK12C
3	10-4106	W.DMT: SCAR EXT LEFT: DMP	1	A	-
4	10-4107	W.DMT: SCAR EXT RIGHT: DMP	1	A	-

REV	A	PRODUCTION RELEASED	7/6/2025	JTL
		DESCRIPTION	DATE	APPROVE

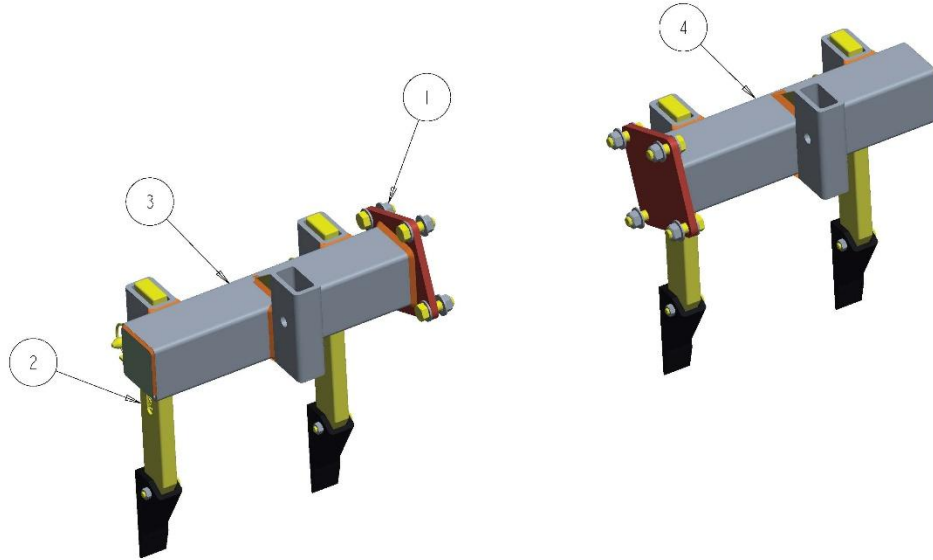

UNITS: INCHES	AS SPECIFIED
CONVERSION: INCHES TO MILLIMETERS	AS SPECIFIED
CONVERSION: MILLIMETERS TO INCHES	AS SPECIFIED
CONVERSION: FEET TO METERS	AS SPECIFIED
CONVERSION: METERS TO FEET	AS SPECIFIED
CONVERSION: POUNDS TO KILOGRAMS	AS SPECIFIED
CONVERSION: KILOGRAMS TO POUNDS	AS SPECIFIED
CONVERSION: GALLONS TO LITERS	AS SPECIFIED
CONVERSION: LITERS TO GALLONS	AS SPECIFIED
CONVERSION: SQUARE FEET TO SQUARE METERS	AS SPECIFIED
CONVERSION: SQUARE METERS TO SQUARE FEET	AS SPECIFIED
CONVERSION: CUBIC FEET TO CUBIC METERS	AS SPECIFIED
CONVERSION: CUBIC METERS TO CUBIC FEET	AS SPECIFIED

MATERIAL	AS SPECIFIED	SURFACE AREA (in ²)	VOLUME (in ³)	WEIGHT (LB)
FINISH	AS SPECIFIED	OVERALL SIZE (in)		
		1810.442	231.864	63.561
		OVERALL SIZE (in)		

DRAWN BY:	JJR
DATE:	3/12/2025

DRAWING STATUS	PRODUCT ON
<small>THIS DRAWING IS THE PROPERTY OF ABI ATTACHMENTS, INC. IT IS TO BE USED ONLY FOR THE PROJECT AND SITE SPECIFICALLY IDENTIFIED HEREON. IT IS NOT TO BE REPRODUCED, COPIED, OR TRANSMITTED IN ANY FORM OR BY ANY MEANS, ELECTRONIC OR MECHANICAL, INCLUDING PHOTOCOPYING, RECORDING, OR BY ANY INFORMATION STORAGE AND RETRIEVAL SYSTEM, WITHOUT THE WRITTEN PERMISSION OF ABI ATTACHMENTS, INC.</small>	

ALT PN	-
ABI ATTACHMENTS, INC. 200 S. DYKSTRA AVE. PULASKI, IN 46344 817-788-7553	
TITLE	
ASM: SCARIFIER EXTENSION: DMP	
SIZE	DWG NO.
3	10-90877
REV	A
SCALE	0.250
SHEET 1 OF 2	

NOTES:

- PART MUST BE FREE OF CRACKS, BURRS, WELD SPATTER, AND RUNS A FINISH.
- ALL GEOMETRY NOT INCLUDED ON PRINT TO COME FROM ELECTRONIC FILES.

ITEM	PART #	DESCRIPTION	QTY	REV	ALT PN
1	0-2097	KIT: HARDWARE: SCARIFIER EXTENSION: DMP	1	Y	-
2	0-4028	12" SCARIFIER WITH HARDWARE	1	Y	SCARSHANK12C
3	0-4106	W.DMT: SCAR EXT LEFT: DMP	-	-	-
4	0-4107	W.DMT: SCAR EXT RIGHT: DMP	-	-	-

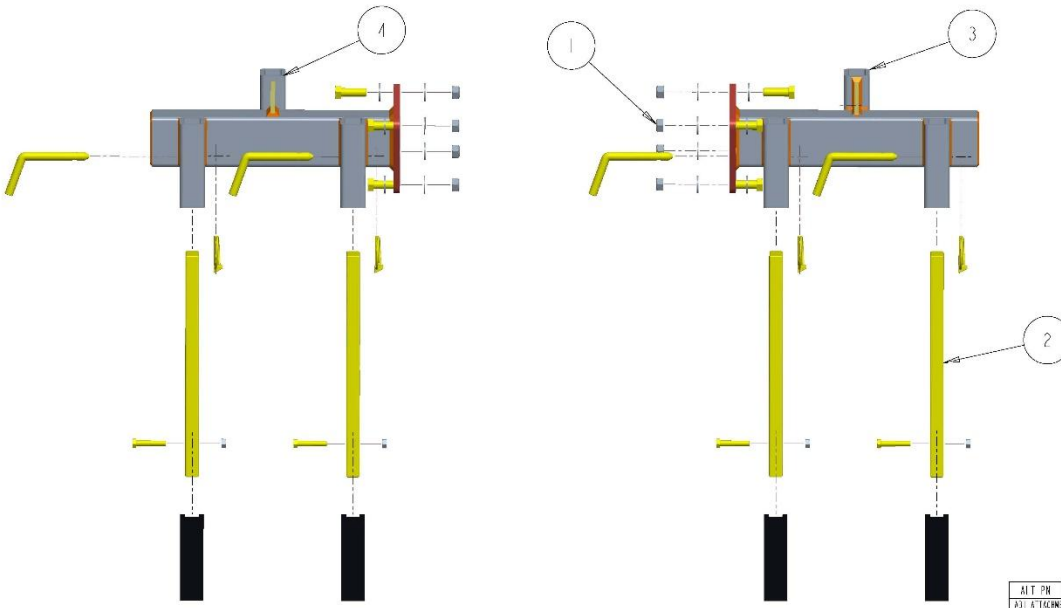

SCALE 0.200

UNITS: INCHES	AS SPECIFIED
CONVERSION: INCHES TO MILLIMETERS	AS SPECIFIED
CONVERSION: MILLIMETERS TO INCHES	AS SPECIFIED
CONVERSION: FEET TO METERS	AS SPECIFIED
CONVERSION: METERS TO FEET	AS SPECIFIED
CONVERSION: POUNDS TO KILOGRAMS	AS SPECIFIED
CONVERSION: KILOGRAMS TO POUNDS	AS SPECIFIED
CONVERSION: GALLONS TO LITERS	AS SPECIFIED
CONVERSION: LITERS TO GALLONS	AS SPECIFIED
CONVERSION: SQUARE FEET TO SQUARE METERS	AS SPECIFIED
CONVERSION: SQUARE METERS TO SQUARE FEET	AS SPECIFIED
CONVERSION: CUBIC FEET TO CUBIC METERS	AS SPECIFIED
CONVERSION: CUBIC METERS TO CUBIC FEET	AS SPECIFIED

MATERIAL	AS SPECIFIED	SURFACE AREA (in ²)	VOLUME (in ³)	WEIGHT (LB)
FINISH	AS SPECIFIED	OVERALL SIZE (in)		
		1810.442	231.864	63.561
		OVERALL SIZE (in)		

DRAWN BY:	JJR
DATE:	3/12/2025

DRAWING STATUS	PRODUCT ON
<small>THIS DRAWING IS THE PROPERTY OF ABI ATTACHMENTS, INC. IT IS TO BE USED ONLY FOR THE PROJECT AND SITE SPECIFICALLY IDENTIFIED HEREON. IT IS NOT TO BE REPRODUCED, COPIED, OR TRANSMITTED IN ANY FORM OR BY ANY MEANS, ELECTRONIC OR MECHANICAL, INCLUDING PHOTOCOPYING, RECORDING, OR BY ANY INFORMATION STORAGE AND RETRIEVAL SYSTEM, WITHOUT THE WRITTEN PERMISSION OF ABI ATTACHMENTS, INC.</small>	

ALT PN	-
ABI ATTACHMENTS, INC. 200 S. DYKSTRA AVE. PULASKI, IN 46344 817-788-7553	
TITLE	
ASM: SCARIFIER EXTENSION: DMP	
SIZE	DWG NO.
3	10-90877
REV	A
SCALE	0.250
SHEET 2 OF 2	

NO. 5:

- PART MUST BE FREE OF CRACKS, BURRS, WELD SPATTER, AND RUNS TO FINISH.
- ALL GEOMETRY NOT INCLUDED ON PRINT TO COME FROM ELECTRONIC FILES.

ITEM	PART #	DESCRIPTION	QTY	REV	ALT. PN
1	10-2021	DRFT. PIN: 1/2"x3.5"x2" MC	2		FM03BP
2	10-2022	LYNCH PIN: 1/2"x1.25"x2" MC	2		FM04LP
3	10-2069B	KIT: HARDWARE: PROF. LE. BLADE EXTENSION: DMP	1	A	-
4	10-4118	WLDMT: PB EXT LEFT: DMP	1	3	-
5	10-4119	WLDMT: PB EXT R. EXT: DMP	1	3	-
6	10-4103D	WLDMT: PROFILE BLADE: DMP	1	C	-

REV	DESCRIPTION	DATE	APPROVE
B	MODIFIED 10-4103D	9/15/2025	JTL
A	PRODUCTION RELEASED	6/27/2025	JTL

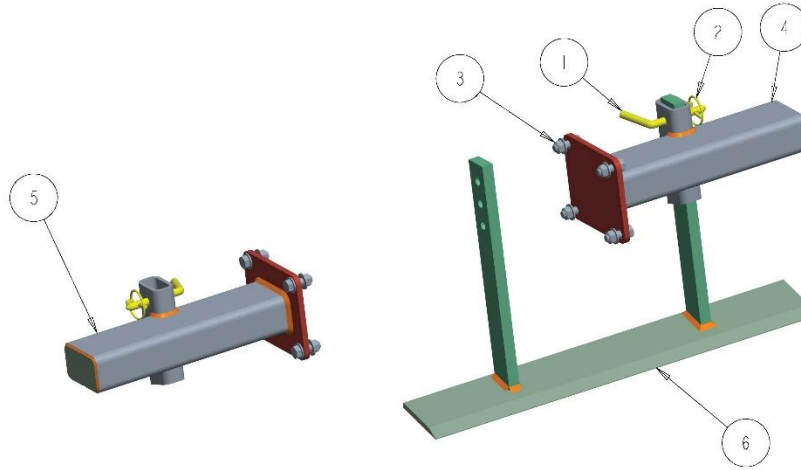

PROPERTY	VALUE
DRIFT PIN PIN	1/2"x3.5"x2" MC
LYNCH PIN PIN	1/2"x1.25"x2" MC
WLDMT: PB EXT LEFT	10-4118
WLDMT: PB EXT R. EXT	10-4119
WLDMT: PROFILE BLADE	10-4103D

MAT'L	AS SPECIFIED	SURFACE AREA (in ²)	VOLUME (in ³)	WEIGHT (LB)
FINISH	AS SPECIFIED	1519.573	211.610	60.319
OVERALL SIZE (in)				

DRAWN BY:	JJR
DATE:	3/12/2025

DRAWING STATUS	PRODUCT ON
PRODUCT ON	PRODUCT ON

ALT. PN	
P31 ATTACHMENTS INC 292 S. SPRAIT AVE. PLYMOUTH, IN 46344 817-788-7553	
TITLE	
ASM: PROFILE BLADE EXTENSION: DMP	
SIZE	DWG NO.
3	10-90878
SCALE: 0.88	SHEET 1 OF 2

NO. 6:

- PART MUST BE FREE OF CRACKS, BURRS, WELD SPATTER, AND RUNS TO FINISH.
- ALL GEOMETRY NOT INCLUDED ON PRINT TO COME FROM ELECTRONIC FILES.

ITEM	PART #	DESCRIPTION	QTY	REV	ALT. PN
1	10-2021	DRFT. PIN: 1/2"x3.5"x2" MC	2	N	FM03BP
2	10-2022	LYNCH PIN: 1/2"x1.25"x2" MC	2	N	FM04LP
3	10-2069B	KIT: HARDWARE: PROF. LE. BLADE EXTENSION: DMP	1	Y	-
4	10-4-018	WLDMT: PB EXT LEFT: DMP	1	-	-
5	10-4-019	WLDMT: PB EXT RIGHT: DMP	1	-	-
6	10-4-020	WLDMT: PROFILE BLADE: DMP	1	-	-

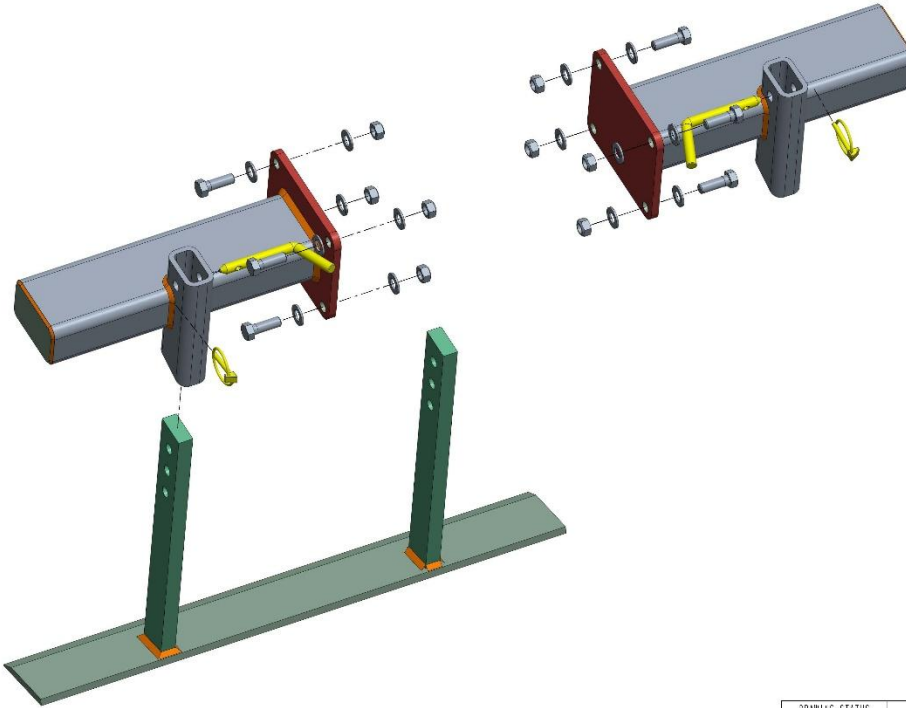

PROPERTY	VALUE
DRIFT PIN PIN	1/2"x3.5"x2" MC
LYNCH PIN PIN	1/2"x1.25"x2" MC
WLDMT: PB EXT LEFT	10-4118
WLDMT: PB EXT R. EXT	10-4119
WLDMT: PROFILE BLADE	10-4103D

MAT'L	AS SPECIFIED	SURFACE AREA (in ²)	VOLUME (in ³)	WEIGHT (LB)
FINISH	AS SPECIFIED	1519.573	211.610	60.319
OVERALL SIZE (in)				

DRAWN BY:	JJR
DATE:	3/12/2025

DRAWING STATUS	PRODUCT ON
PRODUCT ON	PRODUCT ON

ALT. PN	
P31 ATTACHMENTS INC 292 S. SPRAIT AVE. PLYMOUTH, IN 46344 817-788-7553	
TITLE	
ASM: PROFILE BLADE EXTENSION: DMP	
SIZE	DWG NO.
3	10-90878
SCALE: 0.250	SHEET 2 OF 2

NOTES:

- PART MUST BE FREE OF CRACKS, BURRS, WELD SPATTER, AND RUNS A FINISH.
- ALL GEOMETRY NOT INCLUDED ON PRINT TO COME FROM ELECTRONIC FILES.

ITEM	PART #	DESCRIPTION	QTY	REV	ALT PN
1	10-20342	3/8 X 1 3/4 RD WIRE LOCK PIN	6	A	S01036 00
2	10-20399	KIT: HARDWARE: GROOMING ROD EXTENSION: DMP	1	A	-
3	10-31029	ROD: GROOMING: TR3 E	6	D	-
4	10-41020	WLDMT: GR EXT LEFT: DMP	1	A	-
5	10-41021	WLDMT: GR EXT R:G-T: DMP	1	A	-

REV	A	PRODUCTION RELEASED	6/30/2025	JTL
		DESCRIPTION	DATE	APPROVED

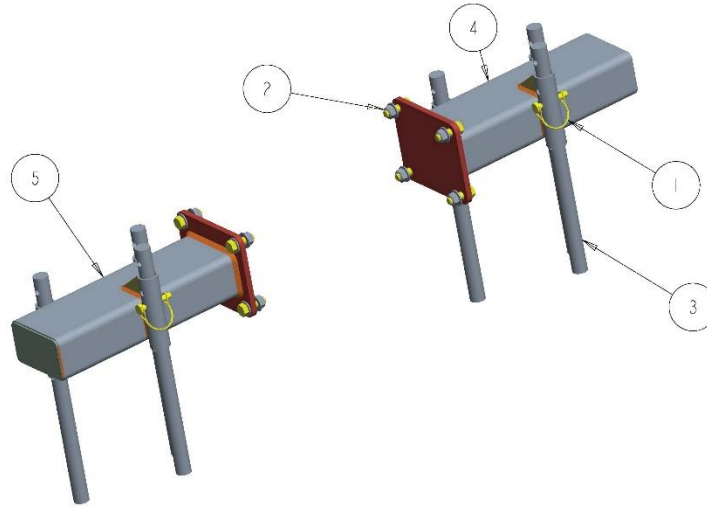

APPROVAL BY: JJJ	DATE: 3/12/2025
DESIGNED BY: JJJ	DATE: 3/12/2025
CHECKED BY: JJJ	DATE: 3/12/2025
DATE: 3/12/2025	BY: JJJ

MATERIAL	AS SPECIFIED	SURFACE AREA (in ²)	VOLUME (in ³)	WEIGHT (LB)
FINISH	AS SPECIFIED	1290.358	228.936	64.913
		OVERALL SIZE (in)		

DRAWN BY:	JJJ
DATE:	3/12/2025

DRAWING STATUS	PRODUCT ON
<small>ALL DIMENSIONS ARE UNLESS OTHERWISE SPECIFIED IN THIS DRAWING. DIMENSIONS ARE TO BE TAKEN FROM THE UNFINISHED SURFACE UNLESS OTHERWISE SPECIFIED. DIMENSIONS ARE TO BE TAKEN FROM THE UNFINISHED SURFACE UNLESS OTHERWISE SPECIFIED. DIMENSIONS ARE TO BE TAKEN FROM THE UNFINISHED SURFACE UNLESS OTHERWISE SPECIFIED.</small>	

ALT PN	-
A31 ATTACHMENTS INC 202 S. DYKST AVE. PLYMOUTH, IN 46344 817-788-7553	
TITLE	
ASM: GROOMING ROD EXTENSION: DMP	
SIZE	DWG NO.
3	10-90879
REV	A
SCALE: 0.88	SHEET 1 OF 2

NOTES:

- PART MUST BE FREE OF CRACKS, BURRS, WELD SPATTER, AND RUNS A FINISH.
- ALL GEOMETRY NOT INCLUDED ON PRINT TO COME FROM ELECTRONIC FILES.

ITEM	PART #	DESCRIPTION	QTY	REV	ALT PN
1	0-20342	3/8 X 1 3/4 RD WIRE LOCK PIN	6	A	S01036102
2	0-20399	KIT: HARDWARE: GROOMING ROD EXTENSION: DMP	1	A	-
3	0-31029	ROD: GROOMING: TR3 E	6	D	-
4	0-41020	WLDMT: GR EXT LEFT: DMP	1	A	-
5	0-41021	WLDMT: GR EXT RIGHT: DMP	1	A	-

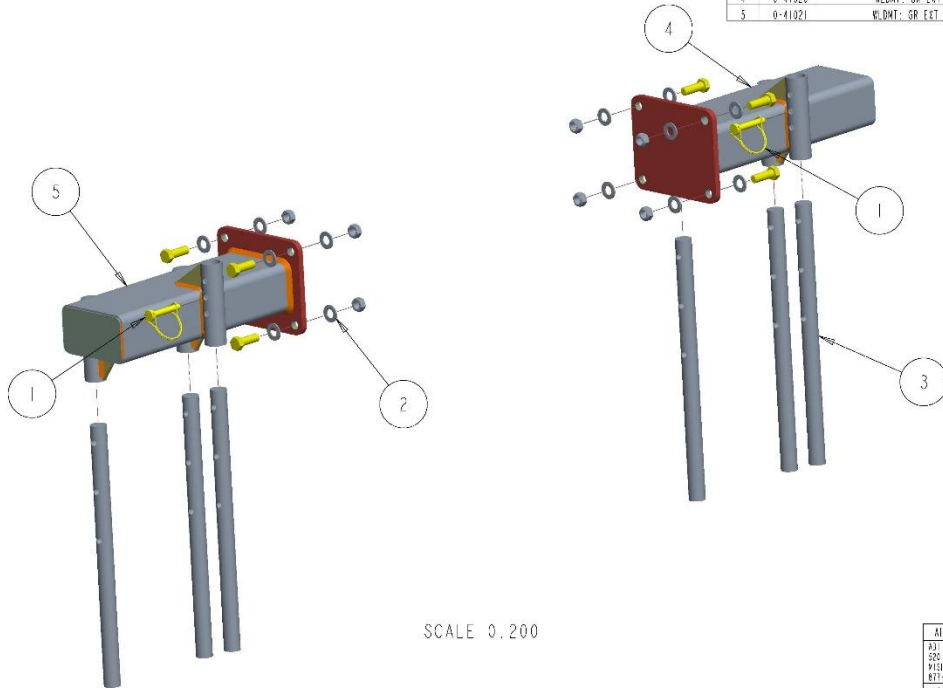

SCALE 0.200

APPROVAL BY: JJJ	DATE: 3/12/2025
DESIGNED BY: JJJ	DATE: 3/12/2025
CHECKED BY: JJJ	DATE: 3/12/2025
DATE: 3/12/2025	BY: JJJ

MATERIAL	AS SPECIFIED	SURFACE AREA (in ²)	VOLUME (in ³)	WEIGHT (LB)
FINISH	AS SPECIFIED	1290.358	228.936	64.913
		OVERALL SIZE (in)		

DRAWN BY:	JJJ
DATE:	3/12/2025

DRAWING STATUS	PRODUCT ON
<small>ALL DIMENSIONS ARE UNLESS OTHERWISE SPECIFIED IN THIS DRAWING. DIMENSIONS ARE TO BE TAKEN FROM THE UNFINISHED SURFACE UNLESS OTHERWISE SPECIFIED. DIMENSIONS ARE TO BE TAKEN FROM THE UNFINISHED SURFACE UNLESS OTHERWISE SPECIFIED. DIMENSIONS ARE TO BE TAKEN FROM THE UNFINISHED SURFACE UNLESS OTHERWISE SPECIFIED.</small>	

ALT PN	-
A31 ATTACHMENTS INC 202 S. DYKST AVE. PLYMOUTH, IN 46344 817-788-7553	
TITLE	
ASM: GROOMING ROD EXTENSION: DMP	
SIZE	DWG NO.
3	10-90879
REV	A
SCALE: 0.88	SHEET 2 OF 2

NO. 1:

- PART MUST BE FREE OF CRACKS, BURRS, WELD SPATTER, AND RUNS TO FINISH.
- ALL GEOMETRY NOT INCLUDED ON PRINT TO COME FROM ELECTRONIC FILES.

ITEM	PART #	DESCRIPTION	QTY	REV	ALT PN
1	10-20700	W.T.: HARDWARE: FIN. SH. RAKE EXTENSION: DMP	1	A	-
2	10-31074	24" FINISH RAKE EXTENSION SILVER, 1/2" RH	1	C	-
3	10-31075	24" FINISH RAKE EXTENSION SILVER, 1/2" LH	1	C	-
4	10-41022	W.DMT.: RAKE EXT LEFT: DMP	1	A	-
5	10-41023	W.DMT.: RAKE EXT RIGHT: DMP	1	A </tr	

REV	A	PRODUCTION RELEASED	12/12/2025	JTL
		DESCRIPTION	DATE	APPROVED

ABSTRACT
 ALL DIMENSIONS ARE IN INCHES UNLESS OTHERWISE SPECIFIED.
 DIMENSIONS ARE TO CENTER UNLESS OTHERWISE SPECIFIED.
 DIMENSIONS ARE TO CENTER UNLESS OTHERWISE SPECIFIED.
 DIMENSIONS ARE TO CENTER UNLESS OTHERWISE SPECIFIED.

MATERIAL	AS SPECIFIED	SURFACE AREA (SQ IN)	VOLUME (CU IN)	WEIGHT (LBS)
FINISH	AS SPECIFIED	OVERALL SIZE (IN)		

DRAWING STATUS	PRODUCT ON
DRAWN BY:	LJL
DATE:	12/12/2025

ALT PN		
A31 ATTACHMENTS INC 200 S. DYKST AVE. VICTORVILLE, IN 48544 877-788-7253		
TITLE		
ASM: 10' CRATED FINISH RAKE EXTENSION: DMP		
SIZE	DWG NO.	REV
3	10-90971	A
SCALE	0.250	SHEET 1 OF 2

NO. 1:

- PART MUST BE FREE OF CRACKS, BURRS, WELD SPATTER, AND RUNS TO FINISH.
- ALL GEOMETRY NOT INCLUDED ON PRINT TO COME FROM ELECTRONIC FILES.

ITEM	PART #	DESCRIPTION	QTY	REV	ALT PN
1	10-20700	W.T.: HARDWARE: FINISH RAKE EXTENSION: DMP	1	A	-
2	10-31074	24" FINISH RAKE EXTENSION SILVER, 1/2" RH	1	C	-
3	10-31075	24" FINISH RAKE EXTENSION SILVER, 1/2" LH	1	C	-
4	10-41022	W.DMT.: RAKE EXT LEFT: DMP	1	A	-
5	10-41023	W.DMT.: RAKE EXT RIGHT: DMP	1	A	-

REV	A	PRODUCTION RELEASED	12/12/2025	JTL
		DESCRIPTION	DATE	APPROVED

ABSTRACT
 ALL DIMENSIONS ARE IN INCHES UNLESS OTHERWISE SPECIFIED.
 DIMENSIONS ARE TO CENTER UNLESS OTHERWISE SPECIFIED.
 DIMENSIONS ARE TO CENTER UNLESS OTHERWISE SPECIFIED.
 DIMENSIONS ARE TO CENTER UNLESS OTHERWISE SPECIFIED.

MATERIAL	AS SPECIFIED	SURFACE AREA (SQ IN)	VOLUME (CU IN)	WEIGHT (LBS)
FINISH	AS SPECIFIED	OVERALL SIZE (IN)		

DRAWING STATUS	PRODUCT ON
DRAWN BY:	LJL
DATE:	12/12/2025

ALT PN		
A31 ATTACHMENTS INC 200 S. DYKST AVE. VICTORVILLE, IN 48544 877-788-7253		
TITLE		
ASM: 10' CRATED FINISH RAKE EXTENSION: DMP		
SIZE	DWG NO.	REV
3	10-90971	A
SCALE	0.250	SHEET 2 OF 2